

DANIEL STEINER

DOMESTIC OFFSET PROJECTS IN AUSTRIA

Possibilities for their implementation and
resulting economic impacts

Doctoral Thesis

to be awarded the degree of
Doctor of Social and Economic Sciences
at the University of Graz, Austria

Graz, 2011

Acknowledgements

I am indebted to many people for their long-lasting support which was invaluable for the success of this research work.

First of all I am grateful to Franz Pretenthaler and Bernhard Schlamadinger from Joanneum Research (Austria) who initiated the financial basis for this work.

I would also like to thank Prof. Karl W. Steininger and Prof. Stefan P. Schleicher from the University of Graz (Austria) for their supervision and helpful suggestions and brainstorming.

Furthermore, I am particularly grateful to Andreas Tuerk and Andreas Niederl from Joanneum Research for their critical discussions and continuous feedback. Also I am indebted to Raimund Kurzmann (Joanneum Research) for providing necessary data and his long-lasting support of data handling.

My deep appreciation belongs also to international debaters who enabled an important reflection of interim results. This unquestionably improved and enabled a higher robustness of results. In particular I would like to mention Wytze van der Gaast (Foundation Joint Implementation Network, Netherlands), Benoit Leguet (Caisse des Depots, France), Dian Phylipsen (Ecofys) as well as Ralf Schüle, Wolfgang Sterk and Hanna Wang-Helmreich (Wuppertal Institute, Germany).

The success is also founded on the innumerable discussions with national experts and stakeholders which enabled to include numerous perceptions.

Abstract (English Version)

Many countries face difficulties in achieving greenhouse gas (GHG) emission reductions through existing incentives and regulations, particularly in sectors not included in the European Emission Trading Scheme (EU ETS). Conflicting incentives as well as legal and financial obstacles contribute to these difficulties. Financial barriers include not only insufficient subsidies but also risk aversion, need for short amortization periods, costs of obtaining information, hurdles in obtaining loans and preferences to invest in product quality rather than energy efficiency.

To support GHG abatement measures some countries have introduced so-called Domestic Offset Projects (DOPs). DOPs enable to support GHG abatement measures in facilities not covered by an ETS by private funds, thereby saving governmental funds. The entity providing financial support for an abatement measure receives certified CO₂-emission reductions, which can be used in certain cases even for ETS-compliance.

The study explores the applicability of DOPs for Austria. A variety of mechanisms for generating Domestic Offsets are analysed, focusing on those that can address potential disadvantages of DOPs, such as potential risk of non-additionality by individual projects and competition for inexpensive abatement opportunities. Potential advantages of DOPs include: capitalizing on private enterprise's ability to discover abatement opportunities; accelerated diffusion of sustainable technologies; and realizing co-benefits of GHG abatements domestically.

Main conclusions are that DOPs based on Joint Implementation may not substantially contribute to achieving a country's Kyoto-target. However, EU legislation made already a first legislative step that this market-based instrument could be applied post-2012, even in the absence of a global climate protection regime. Therefore, preparatory work should be undertaken to enable introduction of a DOP-scheme in 2013 embedded into a European or international (post-2012) framework. At the same time DOPs based on the Voluntary Carbon Offset Market should be further promoted. In any case GHG-reductions achieved by DOPs contribute to economic welfare at least as much as purchases of CO₂-certificates abroad. Moreover, DOPs are to be strictly preferred over achieving domestic GHG-abatements through high-cost incentives.

Abstract (German Version)

Die Erreichung der angepeilten Klimaschutzziele der Bereiche außerhalb des Europäischen Emissionshandelssystems (EU-ETS) mit bestehenden nationalen Instrumenten erweist sich in vielen Ländern als schwierig. Die Gründe dafür sind mehrfacher Natur: Neben Anreizasymmetrien (Mieter-Vermieter) und legislativen Insuffizienzen sind es auch finanzielle Barrieren. Diese finanziellen Barrieren sind nicht immer z.B. durch zu geringe Förderhöhen oder absente Förderungen offensichtlich. Sie betreffen auch Aspekte wie Risikoaversion und damit einhergehend zu kurze (interne) Abschreibungserfordernisse, Kosten der Informationsbeschaffung, etc.

Zum Abbau dieser finanziellen Barrieren, d.h. zur finanziellen Unterstützung von Klimaschutzprojekten, haben einige Länder sogenannte Domestic Offset Projects (DOPs) eingeführt. Dabei können Institutionen, Unternehmen oder Privatpersonen Klimaschutzmaßnahmen in Non-ETS-Bereichen finanziell unterstützen, im Gegenzug erhalten diese eine entsprechende Menge an zertifizierten und teilweise auch zur Compliance verwendbaren CO₂-Emissionsreduktionen.

Die durchgeführte Studie untersucht die Anwendbarkeit von Domestic Offset Projects in Österreich. Dabei werden unterschiedliche Mechanismen untersucht um Domestic Offsets zu generieren. Diese Mechanismen nehmen vor allem Bedacht auf mögliche Nachteile, wie beispielsweise Konkurrenz zwischen Staat und Projektdurchführern um kostengünstige Emissionsreduktionen. Dem gegenüber stehen Vorteile wie das Nutzen der Suchmaschine „Markt“, damit einhergehend eine beschleunigte Diffusion von nachhaltigen Technologien und inländische Co-Effekte (z.B. Schadstoffreduktion).

Aus Sicht der Konsumentenwohlfahrt sind DOPs gegenüber der Möglichkeit von CO₂-Zertifikatszukäufen aus dem Ausland zumindest gleichzusetzen oder zu favorisieren – je nach Bewertung von verringerten Schadstoffemissionen. In jedem Fall sind sie jenen inländischen Emissionsreduktionen vorzuziehen, für deren Stimulierung hohe Zuschüsse notwendig sind.

TABLE OF CONTENTS

1	Executive Summary	1
2	Introduction.....	5
3	Short refresher in international climate policy.....	8
4	Overview of international DOP-schemes.....	10
4.1	The French DOP-scheme	10
4.2	The German DOP-scheme	15
4.3	The Swiss DOP-scheme	18
4.4	The New Zealand DOP-Scheme	23
4.5	DOPs in the Regional Greenhouse Gas Initiative (of the U.S.).....	27
4.6	Discussed DOP-scheme in the Netherlands	31
4.7	Synthesis of findings	32
4.7.1	Extent of the Kyoto-gap	32
4.7.2	Distribution of greenhouse gases among sectors.....	33
4.7.3	Trends of GHG emissions in various sectors.....	34
4.7.4	Project- types eligible and non-eligible for Domestic Offset Projects	36
4.7.5	System for certifying credits of DOPs.....	39
4.7.6	Administrative procedure to generate Offsets.....	39
4.7.7	Provisions to ensure additionality of DOPs	40
4.7.8	Provisions against net-transfer of AAUs	41
4.7.9	Provisions to avoid double counting.....	42
4.7.10	Incompatibilities of DOPs with governmental subsidies.....	44
4.7.11	Provisions to keep transaction and administration costs low.....	45
5	Chances, problems and possible solutions	47
5.1	Chances associated with DOP-schemes.....	47
5.1.1	Using the “search engine market”	47
5.1.2	Accelerated diffusion of technologies.....	47
5.1.3	Appearance of co-effects from GHG abatements domestically.....	48
5.2	Problems associated with DOP-schemes and potential solutions	49
5.2.1	Widening of the emissions gap	49
5.2.2	Competition for cheap abatement possibilities.....	50
5.2.3	Double counting.....	50
5.2.4	Limited abatement potential and high transaction costs	51
6	Austrian circumstances and resulting lessons learned	52
6.1	Austria – its greenhouse gas emissions and trends	52
6.2	Lessons learned for Austria	56

7	Domestic Offset Projects – Classification and mode of operation.....	58
7.1	DOP-scheme based on the voluntary carbon offset market.....	58
7.2	DOP-scheme based on Joint Implementation	61
7.3	Analysis of the instrument “Domestic Offset Projects”.....	64
7.3.1	Cost efficiency	64
7.3.2	Need for public funds.....	68
7.3.3	Flexibility	68
7.3.4	Need for the government to possess certain information	69
7.3.5	Competition for cheap abatement options	69
7.3.6	Support to achieve governmental climate protection targets.....	70
7.3.7	Conclusion	71
8	Interactions of DOPs with other pollution control instruments.....	74
8.1	Interactions of DOPs with the EU-ETS	74
8.2	Interactions of DOPs with subsidies	74
8.3	Interactions of DOPs with taxes on energy use.....	76
8.4	Interactions of DOPs with awareness building measures	78
8.5	Interactions of DOPs with command & control measures	80
8.6	Conclusion.....	82
9	Designing and comparing different DOP-schemes	83
9.1	Option 1: DOP-scheme based on the Voluntary Carbon Offset Market including a tender for projects.....	83
9.2	Option 2: DOP-scheme based on Domestic JI with fractional transfer of economic benefits	85
9.3	Option 3: DOP-scheme based on Domestic JI with discounting of allocated ERUs.....	88
9.4	Option 4: DOP-scheme with the government as investor.....	91
9.5	Comparison of different options of DOP-schemes	93
9.5.1	Cost efficiency	93
9.5.2	Need for public funds.....	94
9.5.3	Flexibility	95
9.5.4	Need for the government to possess certain information	95
9.5.5	Competition for cheap abatement options	96
9.5.6	Support to achieve governmental climate protection targets.....	96
9.6	Conclusion.....	97
10	Economic analysis of Domestic Offset Projects	99
10.1	Case studies.....	99
10.2	Anticipated Effects of analyzed measures to comply with climate protection targets.....	101
10.3	Model description	103
10.3.1	Chosen modeling approach	103
10.3.2	Description of the modeling approach.....	104
10.3.3	Implementation and algorithm	110
10.4	Database	111

10.5 Economic effects	118
10.5.1 Economic effects of case study 1	118
10.5.2 Economic effects of case study 2/2+	121
10.5.3 Economic effects of case study 3	126
10.5.4 Comparison of case studies	129
10.6 Effects including external costs	131
10.6.1 Costs of external effects	131
10.6.2 Reduced emissions of natural gas powered cars	133
10.6.3 Reduced external costs in considered case studies	134
10.6.4 Effects of reduced external costs on results	137
10.7 Sensitivity analysis	139
10.7.1 Elasticity of substitution between capital and labor	139
10.7.2 Armington elasticities for foreign trade	141
10.7.3 External damage costs	142
10.7.4 Impacts of “inconveniences”	145
11 Conclusions	148
12 FAQs	150
13 ANNEX I: Relevant environmental subsidies in Austria	152
13.1.1 Environmental subsidies in Austria in the area of buildings construction	152
13.1.2 Environmental subsidies in Austria in the area of renewable energy	155
13.1.3 Environmental Subsidies in Austria in the area of efficient energy usage	157
13.1.4 Environmental subsidies in Austria in the area of agriculture and forestry	158
13.1.5 Environmental subsidies in Austria in the area of industry and business	158
13.1.6 Environmental subsidies in Austria in the area of transport	159
13.1.7 Environmental Subsidies in Austria only granted by the federal government	160
13.1.8 Other environmental subsidies and schemes to stimulate environmental-friendly behavior on the base of the Austrian state of Styria	161
14 ANNEX II: Ability for MRV of greenhouse gases in different sectors	163
14.1.1 Agriculture and forestry	164
14.1.2 Households and offices	165
14.1.3 Transport	166
14.1.4 Waste	167
14.1.5 Industry not covered by the EU-ETS	168
14.1.6 Power plants not covered by the EU-ETS and energy distribution	170
15 ANNEX III: Specification of emitting sources	171

16 ANNEX IV: Illustrative DOP examples from other countries	177
16.1 France	177
16.2 Germany.....	177
16.3 The Netherlands.....	179
17 Annex V: Calculation of parameters needed in case studies.....	180
18 Annex VI: GHG saving potentials: sectors and quantities	184
18.1 Aggregate of End-use sectors.....	184
18.2 Households	186
18.3 Tertiary sector.....	187
18.4 Transport	189
18.5 Industry.....	190
19 Abbreviations	193
20 Bibliography	194

LIST OF TABLES

Table 1	Greenhouse gas emissions and anticipated achievement of Kyoto-targets with domestic actions	33
Table 2	Share of greenhouse gases per sector (2007).....	33
Table 3	Trends of greenhouse gases per sector in the period 1990 - 2007	34
Table 4	Trends of greenhouse gases per country in the period 1990 – 2007 (excl. LULUCF)	35
Table 5	Sectors which are generally eligible for generating DOPs.....	36
Table 6	Project-types eligible for DOPs.....	37
Table 7	Project-types not eligible for DOPs.....	38
Table 8	Classification of certification procedures for allowances of DOPs	39
Table 9	Administrative procedures to generate credits from Domestic Offset Projects	40
Table 10	Provisions to ensure additionality	41
Table 11	Transfer of Assigned Amount Units by selling allowances of DOPs.....	42
Table 12	Provisions to avoid double counting.....	44
Table 13	Incompatibilities of DOPs with governmental subsidies.....	45
Table 14	Provisions to lower administration and transaction costs.....	46
Table 15	Comparison of DOPs with other, relevant pollution control instruments.....	72
Table 16	Sectoral classification	106
Table 17	Macroeconomic changes in case study 1	119
Table 18	Sectoral economic changes in case study 1	121
Table 19	Net effect of representative installation's certificates purchase	122
Table 20	Net effect of government's actions in case study 2.....	123
Table 21	Macroeconomic changes in case study 2	123
Table 22	Sectoral economic changes in case study 2	124
Table 23	Macroeconomic changes in case study 2+	125
Table 24	Sectoral economic changes in case study 2+	126
Table 25	Macroeconomic changes in case study 3	128
Table 26	Sectoral economic changes in case study 3	129
Table 27	External marginal damage costs per unit of local air pollutant.....	132
Table 28	Emissions of harmful air pollutants of different passenger car engines.....	134

Table 29	Avoided external damage costs in Austria in the course of GHG-abatements in case study 2/2+.....	135
Table 30	Avoided external damage costs in Austria in the course of GHG-abatements in case study 3.....	136
Table 31	Effects of case studies on welfare of consumer at a combined consideration of economic consumer welfare/government welfare and benefits due to locally avoided air pollutants.....	137
Table 32	Effects of different values for elasticity of substitution between capital and labor on economic consumer welfare and economic government welfare (in Mio. €)	139
Table 33	Combined welfare effects (economic and ecologic) for different marginal rates of substitution between capital and labor.	140
Table 34	Effects of case studies on welfare at imposing high values for Armington elasticities.....	141
Table 35	Effects of case studies on welfare at imposing low values for Armington elasticities.....	141
Table 36	Lowest and highest values of external costs per unit of local air pollutant (€/ ton).....	142
Table 37	Avoided external damage costs in Austria in the course of GHG-abatements in case study 2/2+ (“best case approach” and “worst case approach”).....	143
Table 38	Avoided external damage costs in Austria in the course of GHG-abatements in case study 3 (“best case approach” and “worst case approach”).....	144
Table 39	Effects of case studies on welfare of consumer at a combined consideration of economic consumer welfare/government welfare and benefits due to locally avoided air pollutants at applying the “best case approach”.....	144
Table 40	Effects of case studies on welfare of consumer at a combined consideration of economic consumer welfare/government welfare and benefits due to locally avoided air pollutants at applying the “worst case approach”.....	145
Table 41	Effects of different values for “inconvenience costs” on economic welfare (in Mio. €)	146
Table 42	Overview of subsidies in the area of renewable energy by federal states of Austria	157
Table 43	GHG Emissions of the sector “agriculture and forestry” for potential coverage under a Domestic Offset Project scheme.....	164
Table 44	GHG Emissions of the sector “households and offices” for potential coverage under a Domestic Offset Project scheme.....	165

Table 45	GHG Emissions of the sector “transport” for potential coverage under a Domestic Offset Project scheme	166
Table 46	GHG Emissions of the sector “waste” for potential coverage under a Domestic Offset Project scheme	167
Table 47	GHG Emissions of the sector “industry not covered by the EU-ETS” for potential coverage under a Domestic Offset Project scheme.....	168
Table 48	GHG Emissions of the sector “power plants not covered by the EU-ETS and energy distribution” for potential coverage under a Domestic Offset Project scheme	170
Table 49	Greenhouse gas sources of emission category energy (category 1)	171
Table 50	Greenhouse gas sources of emission category industrial processes (category 2).....	172
Table 51	Greenhouse gas sources of emission category solvent and other product use (category 3).....	173
Table 52	Greenhouse gas sources of emission category agriculture (category 4).....	173
Table 53	Greenhouse gas sources of emission category LULUCF (category 5)	175
Table 54	Greenhouse gas sources of emission category waste (category 6).....	176
Table 55	Data for calculating fuel costs savings of natural gas powered cars compared to conventional cars.....	180
Table 56	Vehicle data for passenger cars	181

LIST OF FIGURES

Figure 1	Breakdown of French emissions by sector and in the energy sector (2007).....	10
Figure 2	Change in French greenhouse gas emissions 1990-2007 (in %).....	11
Figure 3	Breakdown of German emissions by sector and in the energy sector (2007).....	15
Figure 4	Change in greenhouse gas emissions 1990-2007 (in %)	16
Figure 5	Breakdown of Swiss emissions by sector and in the energy sector (2007).....	18
Figure 6	Change in Swiss greenhouse gas emissions 1990-2007 (in %).....	19
Figure 7	Process of testing additionality in Switzerland	22
Figure 8	Breakdown of New Zealand emissions by sector and in the energy sector (2007).....	23
Figure 9	Change in New Zealand greenhouse gas emissions 1990-2007 (in %).....	24
Figure 10	Breakdown of U.S. emissions by sector and in the energy sector (2007).....	28
Figure 11	Change in U.S. greenhouse gas emissions 1990-2007 (in %)	28
Figure 12	Breakdown of emissions by sector and in the energy sector (2007, w/o LULUCF)	52
Figure 13	Trend of Austria's GHG emissions from 1990-2007 (w/o LULUCF)	53
Figure 14	Change in greenhouse gas emissions/ removals (1990-2007) in %	53
Figure 15	Schematic illustration of the category of DOP-schemes generating voluntary carbon offset credits.....	59
Figure 16	Schematic illustration of changes of real GHG-emissions and of the Austrian AAU- budget before and after generating voluntary carbon offset credits in Austria	60
Figure 17	Schematic illustration of DOP-schemes based on Domestic JI.....	62
Figure 18	Schematic illustration of changes in real GHG emissions and in Austria's AAUs-budget before and after generating Emission Reduction Units (ERUs)	63
Figure 19	Schematic illustration of abatements costs due to command and control instruments faced by polluters with different marginal cost curves for a certain abatement level X	65
Figure 20	Schematic illustration of abatements costs due economic incentive-based instruments faced by polluters with different marginal cost curves and same abatement level 2*X.....	66

Figure 21	Interactions of Domestic Offset Projects with existing subsidies	75
Figure 22	Interactions of Domestic Offset Projects with taxes on energy use at relatively low marginal abatement costs.....	77
Figure 23	Interactions of Domestic Offset Projects with taxes on energy use at relatively high marginal abatement costs	78
Figure 24	Interactions of Domestic Offset Projects with effective awareness building measures.....	79
Figure 25	Interactions of Domestic Offset Projects with ineffective awareness building measures.....	80
Figure 26	Interactions of Domestic Offset Projects with Command & Control measures	81
Figure 27	Schematic illustration of a DOP-scheme based on generating voluntary offset credits.....	84
Figure 28	Schematic illustration of a DOP-scheme based on Domestic JI with fractional transfer of economic benefits.....	86
Figure 29	Schematic illustration of effects on GHG abatements of DOPs caused by a fractional transfer of economic benefits from the investor to the government.....	87
Figure 30	Schematic illustration of a DOP-scheme based on Domestic JI with discounting of allocated ERUs.....	88
Figure 31	Schematic illustration of discounting the amount of allocated ERUs.....	90
Figure 32	Schematic illustration of a DOP-scheme where the government acts as an investor.....	91
Figure 33	Schematic illustration of money flows in the DOP-scheme with the government as investor	92
Figure 34	Schematic illustration of the nested CES production function	107
Figure 35	Schematic illustration aggregates per category of goods	109
Figure 36	Illustration of the applied Social Accounting Matrix (SAM).....	112
Figure 37	Economic welfare effects (in Mio. €) of analyzed case studies.....	130
Figure 38	Welfare effects (Mio. €) of analyzed case studies.....	138
Figure 39	Total potential to save end-use of energy in Austria	185
Figure 40	Total potential to save end-use of energy in Austria, splitted by fuel savings and electricity savings	185
Figure 41	Fuel saving potential in households (Austria).....	186
Figure 42	Electricity saving potential in households (Austria)	187
Figure 43	Fuel saving potential in the tertiary sector (Austria)	188
Figure 44	Electricity saving potential in the tertiary sector (Austria).....	188
Figure 45	Total saving potential for passenger transport in Austria	189

Figure 46	Total saving potential for goods transport in Austria	190
Figure 47	Fuel saving potential in sector industry (Austria).....	190
Figure 48	Electricity saving potential in sector industry (Austria)	191
Figure 49	Industry saving potential by technology in Austria at a low policy intensity (LPI) scenario	192
Figure 50	Industry saving potential by branch in Austria at a low policy intensity (LPI) scenario.....	192

1 Executive Summary

Motivation

GHG-emissions of many industrial facilities and power plants are restricted due to the European Emission Trading Scheme (EU-ETS). However, further actions for greenhouse gas (GHG) abatements are needed at facilities not covered by the EU-ETS, particularly in order for Austria to achieve its international and European obligations, as well as its internal targets. Although many activities to induce GHG abatements in non-EU-ETS sectors have been initiated, anticipated effects have not materialized in many cases due to numerous barriers. Barriers include the low profitability of desired actions as well as barriers that might not be viewed as financial. Such barriers include risk aversion, resistance to taking out loans, lack of information, time constraints, lack of motivation and concerns about reductions in comfort. Although these barriers are being considered as non-financial, financial compensations might overcome such 'non-financial' barriers. One way to provide these funds could be achieved via Domestic Offset Projects (DOPs), which were already introduced by several countries. While this study focuses on use of DOPs in Austria, it can contribute to wider discussions regarding a European DOP-scheme for the period after 2012.

To answer whether this market-based instrument might be also suitable for Austria, this study surveys in detail major existing design options globally observed, discusses all pros and cons of this market-based instrument and analyses its economic effects compared to alternative policy instrument options. Moreover, it contributes to wider discussions regarding a European DOP-scheme for the period after 2012.

Domestic Offset Projects – what are they?

Domestic Offset Projects induce GHG-emission reductions at facilities not covered by an Emission Trading Scheme. Such projects are financed by private actors but resulting GHG-emission reductions are verified according to international or national rules. Based on verified GHG-emission reductions, certified CO₂-offset credits are generated. These CO₂-offset credits could be used by facilities to comply with GHG-caps, e.g. EU-ETS facilities or for voluntarily offsetting GHG emissions.

Advantages of Domestic Offset Projects

DOP-schemes can use private funds to accelerate technological innovation. In addition, governments often may not have complete information about GHG-abatement possibilities and their costs. DOPs can take advantage of the informational advantage of private actors. Private actors can serve as a 'search engine' for GHG-abatement opportunities and means for overcoming barriers. Such a 'search engine' focused on domestic opportunities has several advantages: it can find low-price GHG-abatements leading to economically efficient target achievement; domestically implemented GHG-abatements can continue to decrease a country's GHG-emissions without the time limits of purchased credits; and co-benefits of

GHG-abatements such as reduced air pollution and increased employment opportunities occur domestically.

Risks and disadvantages

Domestic Offset Projects could be based on several different schemes: Voluntary Carbon Offset Markets; nationally regulated certification procedures as done in Switzerland; or the Joint Implementation (JI) mechanism (or a similar post-2012 mechanism).

DOPs based on JI (or a similar mechanism in a potential future climate protection regime) might be attractive for investors because the generated credits could count as Emission Reduction Units (ERUs).¹ If DOP credits count as ERUs, they could be used for obligation compliance by facilities covered by the EU-ETS, creating a large, liquid market for them. However, to ensure quality credits used in the EU-ETS, ERUs have to be backed-up by an equivalent amount of a country's "Assigned Amount Units" (AAUs)². This would mean that JI-based DOP-credits transferred to EU-ETS facilities would have to be accompanied by equivalent amounts of the host country's AAUs. As a result, a DOP-host country "loses" AAUs equal to the DOP credits generated, resulting, from the viewpoint of the government, in a zero-sum game with respect to achieving the domestic GHG-abatement target. However, *in reality it cannot always be assured that emission reductions achieved by a DOP would not have been achieved also in the absence of the DOP.* Under these circumstances, more AAU would be transferred from the government's AAU account to EU-ETS installations than justified by additional domestic GHG-abatements.

Another possible pitfall of DOPs based on JI is a *potential competition for cheap abatement opportunities between the government and private DOP-developers.* The government has to ensure achievement of its climate target. To achieve this, the government undertakes programs which typically include subsidies. Given its limited budget, the government strives to exploit low-cost GHG abatement options.³ However, developers of DOPs also seek the most cost-effective GHG abatement options. The government attempts to exploit these opportunities to achieve its climate protection targets at the lowest costs while developers of DOPs attempt to exploit them because these measures promise the highest profits from sales of DOP-based credits to purchasers.

Another risk of DOPs is the *problem of counting emission reductions twice* (so-called "double counting"). This error in calculating real GHG reductions of DOPs is not only a matter of DOPs based on JI, but also of DOPs based on national or Voluntary Carbon Offset Market certification procedures. Double counting arises, for example, if DOP-induced GHG-abatements lead also to a reduction in EU-ETS-covered installation emissions: a DOP that reduces electricity demand in buildings can also reduce emissions in electric power plants covered by the EU-ETS. Thus, appropriate provisions have to be introduced to assure that

¹ Credits generated under Joint Implementation called Emission Reduction Units (ERUs)

² Counting unit describing national emission rights under the Kyoto-protocol. One AAU approves to emit one metric ton of CO₂.

³ This is true from the sole perspective of achieving short- and medium-term climate protection targets. From the overall economic perspective and from the perspective of achieving long-term climate protection targets it is advisable to also include co-effects of GHG abatement measures into consideration. Compare Prettenhaler, Steiner, Schlamadinger (2006)

one ton of reduced CO_{2eq} does not result in both ‘freeing up’ a permit to emit and creation of a DOP credit.

An often mentioned pitfall for DOPs is potentially *high transaction costs* compared to the volume of GHG-savings and therefore *limited potential for GHG-abatements* under a DOP-scheme. To address this problem, all design options for DOP-schemes should follow a *programmatic approach* in which small sources are pooled. In addition, MRV (Monitoring, Reporting, Verifying) should be done through statistically valid sampling to limit transaction costs.

Options of DOP-schemes

Options reviewed in this paper include *one based on the Voluntary Carbon Offset Market and three based on Joint Implementation (JI)*.

In the option based on the Voluntary Carbon Offset Market, private actors accomplish additional GHG-abatements which are certified according to appropriate standards.⁴ Generated credits are sold on the Voluntary Carbon Offset Market. The government profits because GHG-emissions are reduced without cost to them and without transferring AAUs. A voluntary carbon offset market has existed in Austria since 2007.⁵ However, traded volumes have been fairly small to date.⁶ Hence, means *are needed to make increase volume*. This may be achieved by increasing opportunities to purchase voluntary offset credits (VOCs) and decreasing their costs. Consumers should be offered the opportunity to offset their GHG-emissions not only for flights⁷ but also for rail journeys, cab rides etc. To lower purchase prices the government might subsidize credits. This would both increase volume and enable the government to target VOCs on project-types which also generate other benefits, e.g. technological innovation, reduced air pollution, or job opportunities. However, to keep governmental subsidies as low as possible, subsidies should be granted on a competitive basis. This could be done by a call for tenders for GHG-mitigation projects where the choice for projects to be subsidized would be driven by requested funding per ton of CO₂-abatement in categories of interest. A side-benefit of reduced GHG emissions would be *improved knowledge about possible lacks of funding for certain GHG-mitigation options*.

The other three DOP-schemes analysed are based on Joint Implementation (JI)⁸. Typically, JI demands on involvement of foreign investors. However, DOPs based on JI could be carried out by domestic project developers – although formally inclusion of a foreign partner may be necessary. Due to reliance on domestic investors, a DOP-scheme based on JI is also called “Domestic JI”. To address the problem of competition for cheap abatement opportunities, the *government can siphon off part of the profits from sales of credits*, as done in France. Siphoned off funds compensate the government for achieving GHG-targets at the

⁴ The strictness of the certifying standards surely depends on the demanded quality of credits.

⁵ See for instance www.climate-austria.at

⁶ In 2009 donations have been made which lead to 10,592 tons of CO₂-reductions over the entire life time of investments. Compare Kommunalkredit Public Consulting [4] 2010, p. 11.

⁷ Passengers of the Austrian Airlines can offset their carbon emissions caused by the flight

⁸ Due to lasting talks about a subsequent climate protection regime it is not obvious now whether the mechanism JI will still exist after 2012. However, the European Commission has provided with Article 24a of the amended Directive 2003/87/EC the legal basis that “kind of” JI projects could be accomplished within the EU after 2012 even in the absence of a global regime which may include JI.

higher costs resulting from DOPs snapping up low cost abatement options.⁹ A second approach is to discount the amount of ERUs granted project developers, as done in New Zealand. This option addresses possible risk of non-additionality by individual projects and reduces the amount of AAUs which have to be transferred. A final option is for generated credits to be owned by the government. The government then compensates private investors for expenses incurred in accomplishing GHG-abatements. Under this option competitive bidding for compensation should be established.

Example of effects of DOPs on consumer welfare

The study assesses the economics of three different ways of achieving a pre-determined GHG-reduction. One way is where (exemplarily) a representative iron and steel producing installation must purchasing 80 % and the government 20 % of the pre-determined GHG-reductions entirely from abroad. The second analysed way is covering the installation's demand for CO₂-certificates entirely by credit purchases from abroad, whereas the government's demand for CO₂-reductions is covered by promotion of domestic actions using subsidies. The third analysed way is covering the entire demand for CO₂-certificates both of the installation as well as of the government via DOPs without granting governmental subsidies.

The most advantageous way of achieving the required GHG-abatement is a strategy which only marginally charges consumers for costs of GHG-abatement measures and simultaneously avoids local emissions of harmful air pollutants. This could be achieved either by DOPs or by other efficient, domestically implemented pollution-control instruments. Inferior to this strategy is purchasing carbon certificates from abroad as no effects from harmful air pollutants are avoided locally. The least attractive strategy is accomplishing GHG-abatement measures domestically when they can only be stimulated by costly incentives.

Conclusion

Domestic Offset Projects could play a specific role in using information from market players about insufficient incentives for GHG-abatements. Up to 2012, however, DOPs based on JI would not much contribute for achieving the Kyoto-target. Nevertheless, up to 2012 the existing Voluntary Carbon Offset Market could be strengthened and preparatory work for a potential DOP-scheme could start which could be embedded in an international or European climate protection regime after 2012.

⁹ This is true if the government pursues to achieve its GHG-mitigation targets mainly by granting subsidies for stimulating climate friendly behavior. However, when pursuing to achieve its GHG-mitigation target mainly by command & control instruments the mentioned higher costs have to be beard by other individuals but not by the government.

2 Introduction

In its 2007 energy and climate package the European Union has set ambitious long-term climate and energy targets¹⁰. By 2020 energy efficiency should be increased by 20 %, the share of renewables in energy consumption should reach 20 % and greenhouse gas (GHG) emissions should be reduced by at least 20 % compared to the levels of 1990. To meet these goals and to comply with Kyoto-targets most GHG-emissions of the industrial and power plants sectors have been already capped by the European Emission Trading Scheme (EU-ETS)¹¹. However, the other part of European greenhouse gas (GHG) emissions – namely those of the Non-ETS-sectors as transportation, buildings (housing), agriculture and waste as well as small power plants and certain industries – is not always developing as intended in some EU member states. Reasons for that might be sometimes lacks of subsidies or gaps in subsidy schemes. However, even at dense subsidy environments current instruments might not lead to aimed savings in greenhouse gas (GHG) emissions. Therefore, not only lacks of subsidies might impede GHG mitigation measures to be carried out but also other barriers¹²:

- Lack of information about energy efficiency and missing motivation among end users as well as among providers of electric equipment, facilities and buildings, intensified by the fact that energy efficiency potential is fragmented in many small and medium efficiency measures.
- Financial restrictions, e.g. shortage of private and public funds, with priorities for investments in the core business being one of potential reasons for the lack in energy efficiency investments.
- Splitted incentives: The person investing into energy efficiency measures (e.g. landlord) is often not the same actor as the beneficiary of that measure (e.g. tenant).
- Risk aversion: Individuals and companies are risk averse with respect to applying new technologies.
- Companies may internally apply higher discount rates for their energy saving investments (aversion against binding of capital not necessary for the core business). Although many energy saving investments may be amortized in a reasonable short period of time, even this short period might seem too long for businesses.

To overcome some of these barriers for GHG mitigation measures in non-ETS sectors, higher efforts are necessary – e.g. time efforts for collecting information about mitigation options (opportunity costs) or taking higher risk. This means, to overcome these barriers additional costs incur. Therefore, revenues might need to be higher for GHG mitigation

¹⁰ Communication from the Commission: „An energy policy for Europe“, 5282/07 [COM(2007) 1]

¹¹ The EU-ETS covers CO₂ emissions from fossil fuel combustion of heat and power plants > 20 MW, mineral oil refineries, coke ovens, iron and steel producing installations, metal ore roasting, cement producing installations, lime producing installations, ceramics producing installations, as well as pulp, paper and board producing installations.

¹² Compare Barthel et al. (2006); p. 11

measures to really be carried out – higher than conventional cost-revenue calculations might show.

To fill potential subsidy gaps or to compensate for costs incurred by other barriers additional financial resources are necessary. To provide these financial resources for intensifying and accelerating GHG mitigation efforts without using national funds, several countries/regions¹³ have implemented so-called Domestic Offset Projects (DOPs). Private agents are encouraged to accomplish GHG mitigation measures in Non-ETS sectors. Achieved GHG reductions are certified and sold to emission trading markets, where they can be used for offsetting GHG emissions. Revenues from these carbon offset certificates (credits) are used – in turn – to cover all costs – also those which are incurred by other barriers.

The main rationale behind DOPs is therefore, to raise additional funds for stimulating additional GHG savings in Non-ETS sectors without providing these funds from the national budget. Closely connected with this is the intention that DOPs should also reduce – at least not widen – a possible gap between real GHG emissions and emission targets agreed under the Kyoto-protocol and under the EU-2020 agreement.

This thesis – therefore – intends to answer whether a scheme for Domestic Offset Projects could be implemented also in Austria, whether it is in line with the governmental strategy to achieve the Kyoto and 2020 targets, and which possible interactions with existing climate protecting instrument could occur. Also, it is necessary to clarify whether DOPs are superior to existing climate protection mechanisms.

For a better understanding of the framework conditions the thesis starts in **chapter 3** with a short description and explanation of relevant parts of the international climate policy. In **chapter 4** relevant foreign DOP-schemes are analyzed on the basis of some crucial characteristics and features. This analysis enables to get a better understanding of advantages and disadvantages of certain scheme designs as well as knowledge about pitfalls and problems of DOPs. **Chapter 5** explicitly summarizes chances and problems of DOPs and provides information about how analyzed DOP-schemes have dealt with problems. In **chapter 6** the existing emissions structure of Austria is displayed to show potential sectors in Austria generally suitable for DOPs. Based on this and based on experiences drawn from other DOP-schemes, crucial characteristics for a potential DOP-scheme in Austria are defined – in other words, characteristics are defined which have to be fulfilled by a DOP-scheme to be suitable for Austria. Keeping experiences from other DOP-schemes as well as specific Austrian needs in mind **chapter 7** provides a classification of DOP-schemes as well as an examination of classified DOP-schemes by means of several criteria (cost efficiency, flexibility etc.). To know whether the new pollution-control instrument “DOPs” leads to synergies or trade-offs with other existing pollution-control instruments, **chapter 8** provides an analysis of this matter. In **chapter 9** several design options of DOP-schemes are presented whose specific conditions intend to diminish potential disadvantages or pitfalls DOPs could lead to (mentioned in chapter 5). Furthermore these provided design options are compared according to criteria used in chapter 7. **Chapter 10** provides an economic analysis of Domestic Offset Projects, thereby comparing this instrument with other

¹³ E.g. Germany, France, Switzerland, New Zealand, US-RGGI (Regional Greenhouse Gas Initiative)

options for achieving GHG abatements. Finally, in **chapter 11** conclusions about the potential significance of DOPs in Austria will be drawn.

3 Short refresher in international climate policy

In 1997 industrialized countries agreed about reductions of greenhouse gases (GHG) at the “Conference of the Parties” (COP) in Kyoto, Japan. In 2005 – after the ratification by 55 countries representing at least 55 % of GHG emissions in 1990 – this agreement, the so-called Kyoto-protocol, came into force.¹⁴

Each ratifying country accepted certain limits of national GHG emissions for the period 2008 to 2012. This amount of “allowed” annual GHG emissions is counted in terms of so-called “Assigned Amount Units” (AAUs), which is a “counting unit” for each country’s budget of allowed GHG emissions within this period. Each metric ton of domestic CO₂ emissions or other greenhouse gas emissions¹⁵ should therefore be backed up by one AAU of the emitting country.

Within the period of 2008-2012, the countries which accepted GHG emission limits should not emit more than they can back-up by their respective amount of AAUs. In case of higher GHG emissions they have to purchase AAUs from other countries whose AAU-budget is higher than their real GHG emissions.

The European Union (EU) has agreed in the Kyoto-protocol to reduce its GHG emissions between 2008 and 2012 by 8 % compared to its GHG emissions in 1990¹⁶. Internally, EU-member states have shared this burden of GHG emission reductions. In the so-called burden-sharing agreement, Austria has accepted a target to reduce its GHG emissions between 2008 and 2012 by 13 % compared to the GHG emission level of 1990.¹⁷

One instrument to achieve the EU target is the European Emission Trading Scheme (EU-ETS). The EU-ETS mainly covers combustion plants (>20 MW), oil refineries, coke ovens, iron and steel plants as well as installations producing cement, glass, lime, bricks, ceramics, pulp and paper¹⁸ and caps their CO₂ emissions, i.e. governments set binding GHG emission targets for covered facilities. The compliance procedure for covered facilities with caps defined by the governments is similar to the procedure of countries to comply with targets of the Kyoto-protocol: covered facilities’ GHG emissions have to be backed-up by so-called European Union Allowances (EUAs), which are mainly allocated to the facilities for free from European governments. If covered facilities emit more than justified by the amount of EUAs they hold, they have to purchase EUAs from other facilities facing a surplus of EUAs.

Due to the trade in European Union Allowances, EUAs move from one EU-member country to another. In the case of EUA-trading among member countries, also AAUs are shifted between these countries by the same extent, because all EUAs have to be backed-up by AAUs.

¹⁴ www.accc.at => Klimapolitik => Kyoto-Protokoll ; November 26, 2008

¹⁵ The quantity of other GHGs is multiplied by a factor representing their global warming potentials in order to be comparable with CO₂

¹⁶ United Nations (1998); p. 20

¹⁷ See United Nations (1998); November 26, 2008

¹⁸ European Union (2003), p. 11

In order to reduce costs for achieving respective climate protection targets – both for countries as well as for capped installations – the Kyoto-protocol has included the provision of the so-called “flexible mechanisms” (Joint Implementation, Clean Development Mechanism). Instead of achieving aimed GHG-reductions entirely in respective countries or installations, GHG-emissions could be reduced elsewhere and be sold to respective countries or installations. This “outsourcing” of GHG-reductions is also known as offsetting carbon emissions.

What might be the future design of the international and European climate policy? The implementation and design of a binding global agreement to combat climate change is not conceivable at the current point, therefore neither the future of the flexible mechanisms. The final design of a post-2012 climate protection scheme might be agreed at the “Conference of the parties” in Durban, 2011. However, no matter how a global agreement to combat climate change will be designed, the European Union has fixed its own climate protection strategy, although details could still change in the course of global negotiations. This includes the continuance of the European emission trading scheme (EU-ETS) which will imply a liquid market for offset certificates. A legal framework for generating eligible offset certificates also in the absence of an international agreement has already passed the European Parliament in the plenary on December 17th, 2008¹⁹: “..., implementing measures may be adopted for issuing allowances or credits in respect of projects administered by Member States that reduce greenhouse gas emissions outside of the Community scheme. Any such measures shall not result in the double-counting of emissions reductions nor impede the undertaking of other policy measures to reduce emissions not covered by the Community scheme.”²⁰ However, the adoption of these ideas is intended to be up to each Member State: “A Member State can refuse the issuance of allowances or credits in respect of projects of certain types that reduce greenhouse gas emissions on its own territory.”²¹

¹⁹ European Parliament (2008)

²⁰ European Parliament (2008), p. 110

²¹ European Parliament (2008), p. 111

4 Overview of international DOP-schemes

International examples of Domestic Offset Project (DOP)-schemes might be “treasure chests” in trying to get a better understanding of this new climate protection instrument. Therefore, international examples of DOP-schemes are illustrated and analyzed. Most of the schemes are embedded in a corresponding national emissions trading scheme.

Analyzed DOP-schemes will be those implemented in France, Germany, Switzerland and New Zealand as well as offsets provisions in the US Regional Greenhouse Gas Initiative (RGGI)²². In addition, corner stones of a potential Dutch DOP-scheme are presented, which is currently in the process of discussion.

4.1 THE FRENCH DOP-SCHEME

France’s greenhouse gas (GHG) emissions structure is characterized by relatively high GHG-emissions from transport, manufacturing industries and construction. At the same time, France faces relatively low emissions from electricity generation due to its high share of nuclear energy production. These facts are demonstrated in Figure 1²³:

Figure 1 Breakdown of French emissions by sector and in the energy sector (2007)

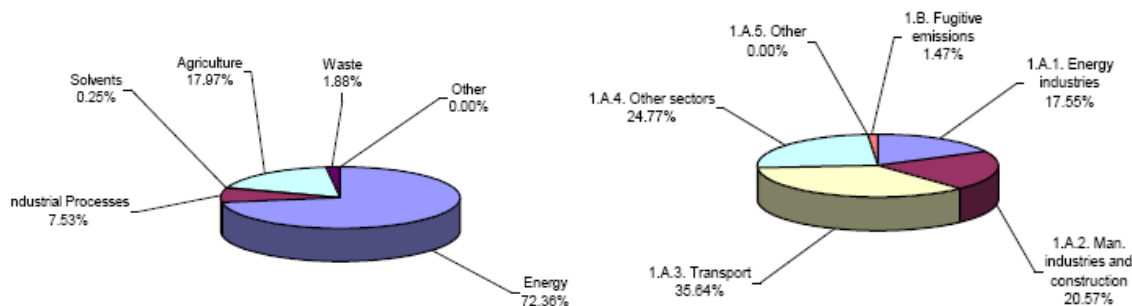

Source: UNFCCC²⁴

The emissions trend in the period 1990-2007 shows an increase in GHG-emissions from transport. A decreasing GHG-emission trend can be observed in energy industries, sharp decreases in fugitive emissions and emissions from industrial processes, solvents as well – to a lesser extent – agriculture and waste. These trends are shown in Figure 2.

²² www.rggi.org

²³ See ANNEX III: Specification of emitting sources

²⁴ http://unfccc.int/files/ghg_emissions_data/application/pdf/fra_ghg_profile.pdf; May 6, 2010

Figure 2 Change in French greenhouse gas emissions 1990-2007 (in %)

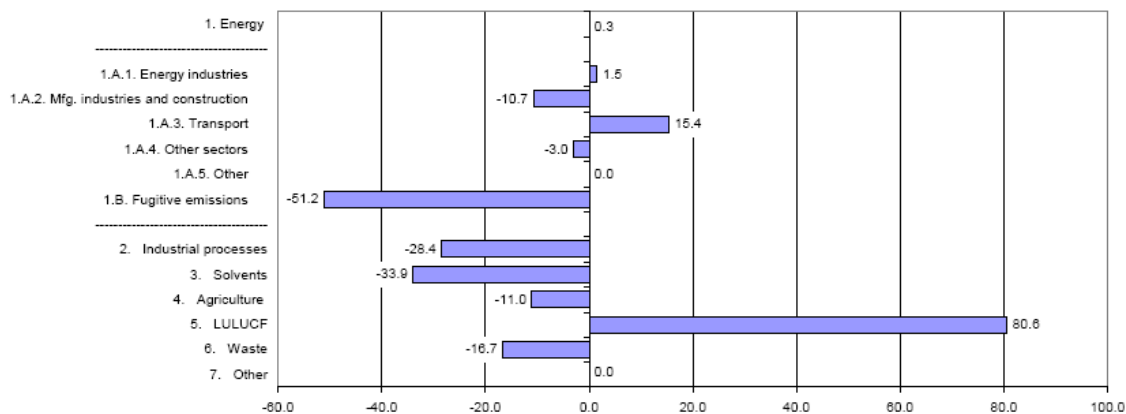

Source: UNFCCC²⁵

Within the EU burden-sharing agreement France has to keep its GHG emissions at the level of 1990²⁶. As the country faced a slight decrease in GHG emissions in the period between 1990 and 2007²⁷, reaching its EU-internal target without extraordinary efforts seems quite plausible from the current point of view.

Institutional framework

France's GHG emissions of certain industries and power plants are covered by the EU-ETS. However, a vast majority (> 70 %)²⁸ of France's GHG emissions is not capped by the European Emission Trading Scheme (EU-ETS)²⁹. These are emissions of small and medium enterprises, from housing and transport, agriculture and waste as well as industrial facilities and power plants not reaching the thresholds.

DOP Mechanism

France has based its DOP-scheme on the generating procedure of Joint Implementation (JI)³⁰. Therefore generated credits are eligible for using as offsets in the EU-ETS – which opens the door to a liquid market. To minimize the administrative burden DOPs are certified on JI track 1. At JI track 1, solely a project's host country is responsible for checking the additionality requirement of projects and for carrying out MRV (Monitoring, Reporting, Verification). Therefore, this procedure provides more freedom compared to JI

²⁵ http://unfccc.int/files/ghg_emissions_data/application/pdf/fra_ghg_profile.pdf; May 6, 2010

²⁶ http://unfccc.int/ghg_data/kp_data_unfccc/base_year_data/items/4354.php; November 26, 2008

²⁷ UNFCCC (2007); p. 9

²⁸ Leguet et al. (2005)

²⁹ Only 27 % of France's GHG emissions are covered in the EU-ETS; based on the presentation of Benoit Leguet (Caisse des Depots) at a side event on offset projects at the "Conference of the parties" (COP 13); December 12, 2007; Bali/ Indonesia

³⁰ Projects based on these flexible mechanisms are intended to be carried out bilaterally – i.e. host and buyer countries are different. However, wishing that JI-projects in France – in fact – were carried out by French project developers, certain bypassing provisions have to be adopted – therefore it is also called "Domestic JI". The bypassing provision is that France has to collaborate with a partner country which also wishes to carry out JI projects unilaterally: At JI projects carried out in France, an intermediary from the partner country is needed and vice versa.

track 2, where an internationally staffed JI Supervisory Committee (JISC) of the UN is responsible for doing that and approving projects.

Supporting factors and motivation

Supporting factors for the DOP-scheme are manifold³¹. "It extends the European system's price signal not subject to CO₂ cap-and-trade schemes, and thereby provides financial inducement to reduce greenhouse gas emissions, by influencing the choice of technology. It encourages the emergence of new ideas for emission reduction, by appealing to project developer's imagination. It supplements the range of existing support schemes It allows France to get closer to its Kyoto-objective: against a declared 10 metric tons emissions reduction, the French Government is delivering only 9 emission reduction units (ERUs)" Another possible advantage is to generate an arbitrage by upgrading low-price AAUs to relatively high-price ERUs due to DOPs.³²

Implications for achieving national GHG abatement targets

Generated credits from JI Projects – also called ERUs (Emission Reduction Units) – are always backed up by the "accounting unit" of a country's allowed budget of annual GHG emissions (Assigned Amount Units, AAUs), according to the Kyoto-protocol. Therefore, selling a certain amount of DOP-credits abroad means that also the host country's budget of GHG emissions negotiated in the Kyoto-protocol decreases. This decrease in France's budget of AAUs is compensated – if full additionality is assured – by decreases of real emissions by the same extent. To ensure that not more AAUs are transferred abroad than justified by real and domestic GHG emission reductions (e.g. by partial non-additionality), France has included a discounting provision – as mentioned above: "Against a declared 10 metric tons emissions reduction, the French government is delivering only 9 Emission Reduction Units (ERUs), thus enabling it to reach its Kyoto objective."³³ This can be also seen as an insurance premium for non-additional projects being in the project portfolio, although strict additionality standards are imposed. Therefore – if strict additionality is taking as granted – this provision helps France to reach international GHG abatement targets in the short run as well as in the long run.

Sectors

France has chosen to principally recognize the sectors transport, agriculture & forestry, buildings (residential) and industrial installations not covered by the EU-ETS as eligible for generating offset credits³⁴. To carry out projects in these sectors a recognized methodology is obligatory. For the following project types methodologies exist³⁵, although the number of eligible project types could increase by time:

- Methane capture from agricultural processes (cattle breeding)

³¹ See Bodiguel, Andre, Leguet (2008); pp.2 & 3

³² Personal communication with Benoit Leguet, April 2009

³³ See Bodiguel, Andre, Leguet (2008); p.2

³⁴ Leguet et al. (2005); pp. 2 & 3

³⁵ See Bodiguel et al. (2008); p. 3

- Reduction of HFC emissions from commercial cooling and in the food production sector
- Usage of bio-waste to generate biogas for substitution of natural gas in the transport sector
- Heat production which reduces fossil fuel consumption (for new and existing facilities)
- Flaring of GHGs which are emitted by industrial processes

The following project types are excluded from the DOP-scheme:³⁶:

- Projects which only produce electricity
- Production and/ or promotion of use of biofuels which are already included in the national plan for biofuels (“Plan Biocarburants”)
- Carbon sequestration by all various types of biomass
- Projects which induce emission reductions in sectors covered by the EU-ETS (power plants, cement and paper production facilities, etc.)
- Reduction of fertilizers in agriculture
- Projects which became operational before 2007³⁷
- Projects in French oversea territories
- Climate research and development, consulting and information dissemination

Administrative procedures

As the French DOP-scheme is set up under the framework of JI³⁸, the administrative procedures are the same as for JI. After the submission of the project proposal (PDD), the PDD will be analyzed whether the project fulfills additionality-, measurability- and permanence requirements, etc. If accepted, the project can be implemented and GHG emission reductions will be monitored. As soon as emission reductions are verified, credits (ERUs) will be allocated.

In order to keep transaction and administration costs low, France decided to choose a standard-based approach rather than a project-by-project approach³⁹. This means, rather than deciding each case separately whether a project is eligible under the DOP-scheme and its monitoring and verifying techniques are appropriate, France has defined eligible methodologies for project-types according to necessary monitoring and verifying techniques in advance. This implies that project developers face fewer risks – and therefore less costs – that projects might not be accepted after much effort was taken for project planning beforehand. Surely, by predetermining methodologies (and therefore project-types), the potential to find innovative opportunities of GHG-reduction in non-capped sectors is limited only to projects which suit to these methodologies.

³⁶ <http://www.caissedesdepots.fr/spip.php?article643> ; November 26, 2008

³⁷ See also section 4.7.7 Provisions to ensure additionality of DOPs

³⁸ Bodiguel, Andre, Leguet (2008), p. 1

³⁹ See approved methodologies from Bodiguel, Andre, Leguet (2008); p. 6

In order to keep administrative costs lower for public authorities, a minimum size was established for DOPs. Emission reduction projects under the DOP-scheme must mitigate a minimum of 10,000 tons⁴⁰ of CO₂eq⁴¹ over the Kyoto-period 2008-2012, smaller projects must be aggregated to reach at least this minimum threshold.

Compatibility with governmental subsidies

A further important question in setting up a DOP-scheme is the compatibility of governmental subsidies with DOPs, i.e. whether individuals are allowed to apply for governmental grants for a GHG-reducing project while stating the same project as DOP and therefore earning revenues from selling generated offset credits (“double funding”). The French DOP-scheme does not exclude the co-existence of DOPs and subsidies in general: “Combining with other methods is [therefore] not forbidden, provided that the project developer demonstrates that the project is additional. However, the domestic offset project mechanism must not be thought of as being merely an additional method of financing existing projects and thus improving the owner’s profit margin (windfall effect).”⁴² The aspect of compatibility with governmental subsidies is mainly an issue of additionality as discussed in the subsequent paragraph.

Additionality

Projects are additional if they were not carried out in the absence of the extra financial incentives provided by the carbon market⁴³. In order to ensure that Domestic Offset Projects are additional, France tests this⁴⁴ – as usually in a JI process – by applying an additionality test⁴⁵. To test additionality of projects, developers of DOPs may consider two aspects. One aspect is based on financial and economic indicators: “An additional project must, in the absence of income linked to carbon credits, be less profitable than alternative investments, taking into account incentives from which it could also benefit (electricity repurchase prices, energy saving certificates, etc).”⁴⁶ The other aspect is based on the identification of barriers: “An additional project must, in the absence of running the project like a “Kyoto” project, be affected by barriers that prevent its implementation. Examples of these would be a new technology, project acceptance problems, etc.”⁴⁷

However, even if these two aspects could be applied to projects, they would be considered as non-additional if they were forced already by legislation or became operational before 2007.⁴⁸

⁴⁰ See <http://www.caissedesdepots.fr/spip.php?article643> ; November 26, 2008

⁴¹ CO₂-equivalent

⁴² Bodiguel, Andre, Leguet (2008), p. 2

⁴³ See also in the FAQ-section for an explanation of „additionality“ at the end of this thesis

⁴⁴ For a detailed description of the methodology for additionality tests see UNFCCC/CCNUCC (2004)

⁴⁵ Compare Bodiguel, Andre, Leguet (2008); p. 2

⁴⁶ Ibid.

⁴⁷ Ibid.

⁴⁸ See <http://www.caissedesdepots.fr/spip.php?article643> ; November 26, 2008

Double counting⁴⁹

One important criterion of a serious DOP-scheme is that it avoids double counting of GHG mitigation effects. Double counting means that one Domestic Offset Project generates, firstly, DOP-credits (in the sector not capped by the EU-ETS) and, secondly, also leads to – relatively substantial – lower output and, therefore, emissions decreases in the (EU-ETS) capped facilities. This second effect causes a release of allocated emission rights to the emissions market of the affected facilities. Therefore, these two effects imply that one GHG mitigation activity would result in the release of an amount of credits, which is twice as much as justified by the extent of the activity. Thus, the French DOP-scheme excludes projects which solely produce electricity or lead to emissions decreases in the facilities capped under the EU-ETS⁵⁰.

4.2 THE GERMAN DOP-SCHEME

Germany’s greenhouse gas (GHG) structure is characterized by high emissions from energy industries and – compared to other analyzed countries – industrial processes. On the other hand, Germany faces relatively little GHG emissions from the transport sector. This is illustrated in Figure 3⁵¹:

Figure 3 Breakdown of German emissions by sector and in the energy sector (2007)

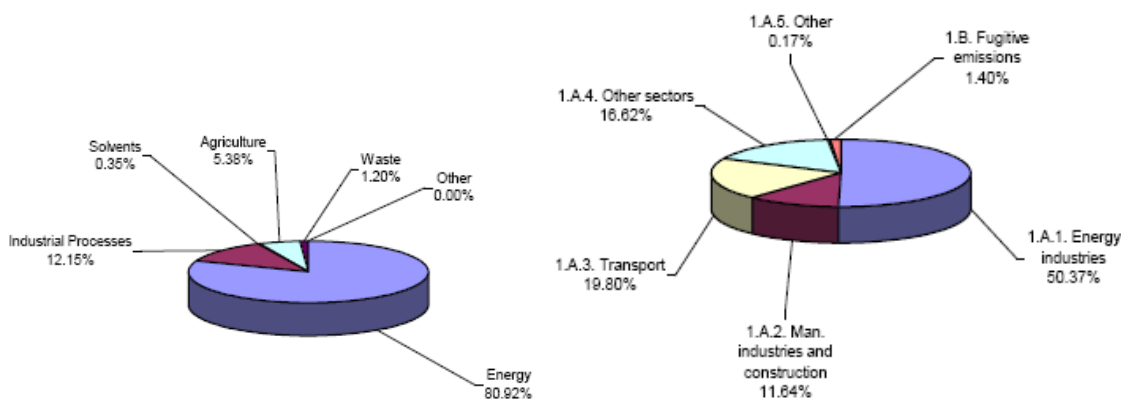

Source: UNFCCC⁵²

The emission trend in the period 1990-2007 shows decreases in all sectors. This is depicted in Figure 4.

⁴⁹ See also chapter „5.2.3 Double counting“ for a more detailed explanation
⁵⁰ See <http://www.caissedesdepots.fr/spip.php?article643> ; November 26, 2008
⁵¹ See ANNEX III: Specification of emitting sources
⁵² http://unfccc.int/files/ghg_emissions_data/application/pdf/deu_ghg_profile.pdf ; May 6, 2010

Figure 4 Change in greenhouse gas emissions 1990-2007 (in %)

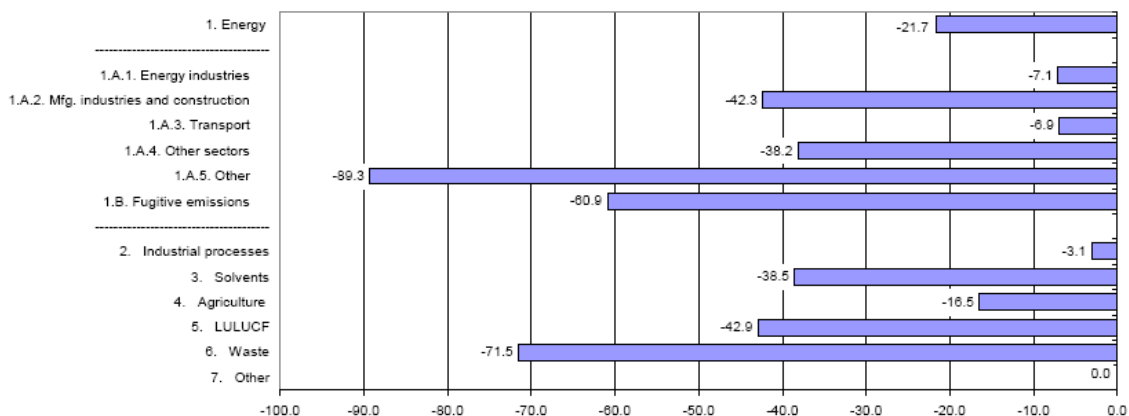

Source: UNFCCC⁵³

Within the burden sharing agreement of the EU, Germany has to lower its GHG emissions by 21 %⁵⁴ compared to its level of GHG emissions in 1990. As GHG-emissions in Germany have been lowered substantially, reaching its EU-internal target seems quite plausible from the current point of view.

Institutional framework

As of 2009, approximately half⁵⁵ of Germany's GHG emissions are capped by the European Emission Trading Scheme (EU-ETS). To provide an additional incentive to lower GHG emissions in the sectors not covered by the EU-ETS, Germany has introduced a DOP-scheme in 2008.

DOP mechanism

Similar to France, DOPs in Germany are based on JI track 1.⁵⁶ However, also JI track 2 is possible if project developers wish so. As ERUs (Emission Reduction Units) are generated from DOPs, they can be used for compliance e.g. in the EU-ETS or other emission trading schemes. In July 7, 2009 34 projects are approved or in the state of the approval procedure.⁵⁷

Supporting factors and motivation

Supporting factors for allowing Domestic JI projects in Germany are as manifold as they are in France: DOPs offer "the possibility to use a market instrument to create incentives for emissions reductions. This approach can complement other regulatory or promotional activities by the state and in several cases is more efficient in reaching target groups. It also

⁵³ http://unfccc.int/files/ghg_emissions_data/application/pdf/deu_ghg_profile.pdf; May 6, 2010

⁵⁴ http://unfccc.int/ghg_data/kp_data_unfccc/base_year_data/items/4354.php; November 27, 2008

⁵⁵ 54 % of Germany's GHG emissions have been covered by the EU-ETS in 2006; German Umweltbundesamt (2007), p. 4

⁵⁶ More information about the operating mode at Sterk, Arens (2006), p. 28

taps the creative potential of the private sector.”⁵⁸ Also, DOPs might be seen as one instrument to accelerate dissemination of sustainable technologies and financing and promoting innovation measures⁵⁹. Furthermore it is seen as a possibility to examine new approaches in climate policy as programmatic approaches⁶⁰ for GHG mitigation activities.

Implications for achieving national GHG abatement targets

As mentioned before, credits from JI-based GHG mitigation measures – also called ERUs (Emission reduction Units) – have always to be backed up by AAUs⁶¹. This implies for Germany⁶² that selling credits from JI-based GHG mitigation measures (ERUs) abroad leads also to a loss of the same amount of AAUs from Germany. In theory, this loss is compensated by corresponding real GHG reductions in Germany. Therefore – in theory⁶³ – this DOP-scheme neither widens nor reduces Germany’s Kyoto-gap. However, achieved GHG reductions within the period 2008-2012 ease the achievement of post-2012 targets.

Sectors

In Germany there is no restriction of the DOP-scheme to certain non-ETS-sectors, as long as they do not face a double counting problem. However, each (programmatic) DOP faces specific restrictions. For instance, the JIM.NRW⁶⁴ does not accept the installation of electricity based heating systems or heat pumps.⁶⁵

Administrative procedures

As the German DOP-scheme is based on JI, the administrative procedure follows the rules of JI. When carrying out programmatic projects⁶⁶, in principle the guidelines for programmatic CDM-projects (“CDM Program for Activities”) are applied. However, Germany allows some exemptions and relaxations of these guidelines. For example, it allows the combination of different project types and therefore different methodologies within one programmatic project, which is not permitted at CDM projects.

Compatibility with governmental subsidies

Germany does not allow GHG mitigation projects to be assigned as DOPs if these projects where already subsidized by public funds. The reason for that is based on problems for

⁵⁷ Personal information of Annette Größ, Future Camp, Germany; July 10, 2009.

⁵⁸ Smuda (2009)

⁵⁹ http://www.co2-handel.de/media/07/10_dokumente/50_Veranstaltungsprogramme/eanrw_jimprojekt_q_eanrw.pdf; JIM.NRW – Joint Implementation Modellprojekt NRW. Informationsveranstaltung für Investoren, Interessenvertreter und Öffentlichkeit; event from May 9, 2007 in Duisburg/ Germany; November 28, 2008

⁶⁰ A programmatic approach pools many small-scale projects similar to a pooling approach. However, the specialty of this approach is that project participants can start their participation at any time within the project duration. Also MRV is done only on a sample to limit administration and transaction costs.

⁶¹ AAUs (Assigned Amount Units) is the “currency” of a country’s budget of annual GHG emissions according to the Kyoto-agreement.

⁶² As it was the case for France

⁶³ It might happen that not all carried out GHG mitigation projects are additional. In this case, real GHG emission reductions induced by these projects were smaller than transferred ERUs and therefore AAUs.

⁶⁴ Joint Implementation Modellprojekt. Nordrhein-Westfalen

⁶⁵ <http://www.energieagentur.nrw.de/emissionshandel/page.asp?TopCatID=&CatID=&RubrikID=6398>; June 6, 2010

⁶⁶ A programmatic project can be seen as a conglomerate of many small-scale projects

setting the baseline: “The German Project Mechanism Law claims that financial incentives that are already granted for the project have to be deducted from the baseline. Practically this is not really feasible, therefore project developers have to decide whether to use subsidies or the incentives of JI, but not a combination of both.”⁶⁷

Additionality

Germany examines additionality of projects by applying usual CDM-additionality tests.

Double counting

Germany excludes project-types leading to double counting of GHG-mitigation effects.

4.3 THE SWISS DOP-SCHEME

The Swiss greenhouse gas (GHG) emission structure is characterized by relatively high emissions from transport and other sectors (according to the classification of the UNFCCC, 1.A.4. Other sectors⁶⁸). At the same time it faces relatively low emissions in energy industries or industrial processes. This can be seen in Figure 5⁶⁹:

Figure 5 Breakdown of Swiss emissions by sector and in the energy sector (2007)

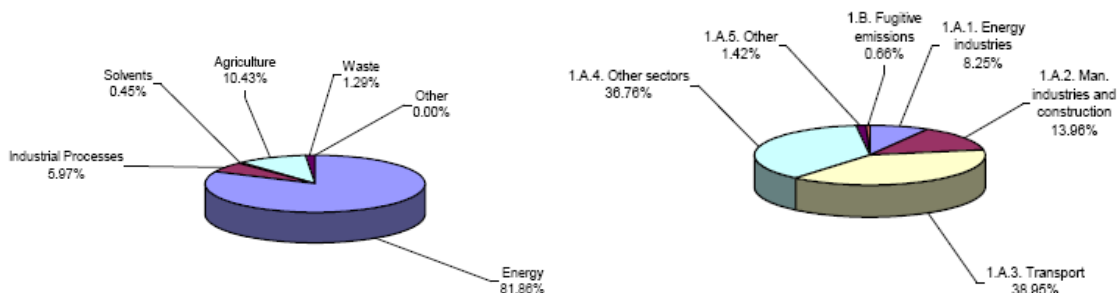

Source: UNFCCC⁷⁰

The emission trend in the period 1990-2007 shows a sharp increase in GHG emissions of energy industries and in the emissions classification “others” (1.A.5., emissions not specified elsewhere of emissions from energy). A sharp emissions’ decline can be observed in fugitive emissions, solvents and waste.

⁶⁷ Smuda (2009)

⁶⁸ See ANNEX III: Specification of emitting sources

⁶⁹ See ANNEX III: Specification of emitting sources

⁷⁰ http://unfccc.int/files/ghg_emissions_data/application/pdf/che_ghg_profile.pdf; May 6, 2010

Figure 6 Change in Swiss greenhouse gas emissions 1990-2007 (in %)

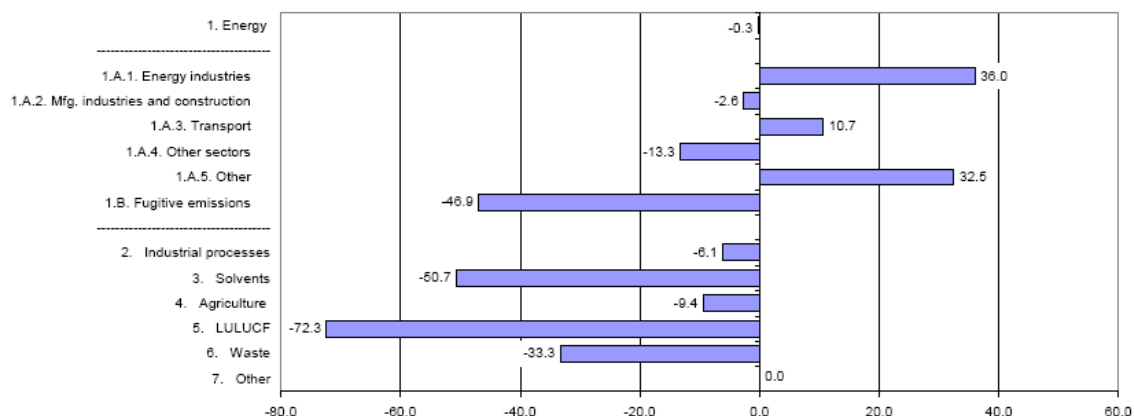

Source: UNFCCC⁷¹

According to the Kyoto-protocol Switzerland has to achieve a reduction of GHG emissions compared to 1990 of 8 %⁷². Considering the decrease in GHG emissions so far⁷³ Switzerland faces a moderate Kyoto-gap.

Institutional framework

Since 2008, Switzerland has established a CO₂-charge on combustibles. Enterprises which have agreed voluntarily for GHG reduction targets can participate in the Swiss emission trading scheme. In return these companies get released from the CO₂-charge.

GHG emissions from natural gas fired combined heat and power plants (CHPs) are excluded from the CO₂-charge. Instead, these facilities are committed to compensate for their GHG emissions by appropriate GHG mitigation measures outside their facilities; at least 70 % of GHG emissions have to be offset domestically⁷⁴. In order to provide enough domestically generated offset credits to make up for GHG-emissions of these plants, a de facto Domestic Offset Project-scheme is implemented.

DOP-mechanism

The Swiss DOP-scheme to generate credits for offsetting GHG emissions from natural gas fired CHPs is not based on the flexible mechanisms of the Kyoto-protocol. However, even if generated offset credits are not eligible e.g. within the EU, this allows no conclusions to be drawn about the reliability of these credits: the Swiss DOP-scheme orients itself along the criteria for generating CDM (Clean Development Mechanism) projects⁷⁵.

⁷¹ http://unfccc.int/files/ghg_emissions_data/application/pdf/che_ghg_profile.pdf; May 6, 2010

⁷² http://unfccc.int/ghg_data/kp_data_unfccc/base_year_data/items/4354.php; November 27, 2008

⁷³ UNFCCC(2009), p.9

⁷⁴ <http://www.bafu.admin.ch/dokumentation/medieninformation/00962/index.html?lang=de&msg-id=19126>; December 1, 2008

⁷⁵ <http://www.bafu.admin.ch/dokumentation/medieninformation/00962/index.html?lang=de&msg-id=19126>; December 1, 2008

Supporting factors and motivation

The rationale behind the Swiss DOP-scheme is to fully compensate for GHG emissions from combined natural gas fired heat and power plants⁷⁶.

Implications for achieving national GHG abatement targets

As generated offset credits are not based on JI, credits are not backed-up by Swiss AAUs and, therefore, cannot be used for compliance reasons outside Switzerland. This means, that no transfer of Swiss AAUs happens. As the DOP-scheme reduces real GHG emissions in Switzerland but does not cause any export of AAUs, this DOP-schemes helps Switzerland to achieve its international GHG abatement targets.

Sectors

The following summary shows eligible GHG mitigation measures for DOPs in Switzerland⁷⁷:

- Usage and avoidance of surplus heat of power plants and industrial facilities (supply side efficiency measures)
- More efficient usage of industrial heat on the customers' side (demand side efficiency measures), fuel switch, optimization of specific facilities
- Renewable energies – production of biogas from biomass
- Fuel switch: heat production due to combustion of biomass, usage of heat pumps, heating by solar energy, change of existing facilities for heat production and electricity generation from carbon intensive to low carbon emitting technologies
- Transport – efficiency improvements of passenger and commodities transports
- Flaring or energetic usage of surplus methane
- Avoiding and substituting F-gases
- Avoiding and substituting N₂O

In principal, measures which oppose overall targets of the federal energy- and climate policy are non-eligible even if they fulfill other obligations for scheme participation. These are projects which increase the overall electricity demand even if they reduce the consumption of fossil fuels⁷⁸. Furthermore, the Swiss federal government has defined certain project-types which are not eligible at all⁷⁹:

- Nuclear power projects
- Biological and geological carbon sequestration (afforestation, reforestation, carbon capture and storage)

⁷⁶ Schweizer Bundesamt für Umwelt (BAFU), Schweizer Bundesamt für Energie (BFE) (2008); p. 7

⁷⁷ Schweizer Bundesamt für Umwelt (BAFU), Schweizer Bundesamt für Energie (BFE) (2008); pp. 10/11

⁷⁸ *Ibid.*, p. 8

⁷⁹ *Ibid.*, p. 9

- Climate related research and development, information and consulting (“soft measures”)
- Projects with liquid biofuels

Administrative procedures

The administrative procedure to generate appropriate carbon compensations for GHG emissions of combined natural gas fired heat and power plants is the following⁸⁰:

- Submission of the project proposal
- Registration of the project, as soon as the project proposal is considered eligible by the public authorities in charge
- Implementation of the projects by the project submitter (= project implementer)
- The project implementer computes GHG emission reductions annually. These reports are checked by independent verifiers
- The project implementer submits its monitoring and verification reports annually to the responsible public authorities
- After the public authorities have verified submitted reports they allocate domestically generated carbon certificates/credits. These carbon certificates are valid for compensating GHG emissions of combined natural gas fired heat and power plants in Switzerland.

To ensure that enough carbon offset credits are generated domestically, transaction and administration costs have to be low enough in order that mitigation projects are attractive for investors. Therefore, the Swiss government has included certain provisions which are also used in other DOP-schemes. One of these is the possibility to pool small-scale projects in order to achieve minimum sizes for projects⁸¹. To ease the computation of GHG emission reductions for project implementers, the Swiss government has provided certain standard methods to estimate emissions of a BAU-scenario. This pool of standard methods covers many of possible project-types⁸². Also, the government is providing a pre-check of the project proposal and gives recommendations⁸³, in order to minimize the risk of failing for project developers.

Compatibility with governmental subsidies

The Swiss DOP-scheme does not principally exclude the co-existence of (governmental) funding and revenues from sales of DOP-credits. In principle, DOPs should not overlap with funding schemes of “Energie Schweiz”, Swiss cantons or municipalities⁸⁴. However, the Swiss government has recognized that even due to co-funding of GHG mitigation measures by sales-revenues from DOP-credits, sometimes the break-even of certain projects might still not be achieved. Therefore, in the case of subsidizing DOPs by public funds, this information

⁸⁰ According to Schweizer Bundesamt für Umwelt (BAFU), Schweizer Bundesamt für Energie (BFE) (2008); pp. 13 and following

⁸¹ Schweizer Bundesamt für Umwelt (BAFU), Schweizer Bundesamt für Energie (BFE) (2008); pp. 9 and 12

⁸² *Ibid.*, pp. 22 et seqq.

⁸³ *Ibid.*; p. 14

⁸⁴ *Ibid.*, p. 16

has only to be stated in the project proposal and to be taken into consideration during the additionality analysis⁸⁵. If public funds have subsidized a GHG-reducing activity declared as a DOP, GHG-emission reductions are proportionally assigned also to public authorities.⁸⁶

Additionality

To guarantee the additionality of DOPs, Switzerland is applying a strict additionality test based on CDM.

Figure 7 Process of testing additionality in Switzerland

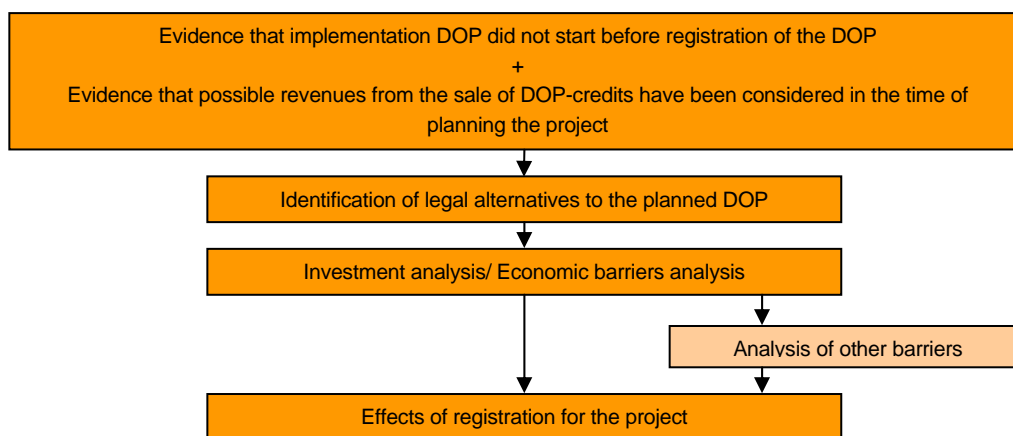

Source: Schweizer Bundesamt für Umwelt (BAFU), Schweizer Bundesamt für Energie (BFE)⁸⁷

According to this additionality test, project implementers have to prove that DOPs had not been planned before January 1, 2007. In any case the operation of GHG mitigation actions must start after the registration in order to be eligible as DOPs⁸⁸.

A special focus is laid on companies which are excluded from the CO₂-tax and therefore participate in the Swiss ETS. These companies are excluded from generating DOPs within their installations as extended efforts already result in a release of ETS-credits.⁸⁹ In addition, renewable energy projects are specially treated: as renewable-based electricity generation is already subsidized by the Swiss feed-in tariff system, biomass fired combined heat and power plants are allowed to generate DOP-credits only from heat production – if they can prove additionality⁹⁰. In contrast to that, facilities which have agreed upon voluntary emission reduction targets⁹¹ can implement DOP without limitations⁹².

⁸⁵ Schweizer Bundesamt für Umwelt (BAFU), Schweizer Bundesamt für Energie (BFE) (2008); p. 17

⁸⁶ *Ibid.*; p. 16

⁸⁷ *Ibid.*; p. 30

⁸⁸ *Ibid.*; p. 8

⁸⁹ *Ibid.*; p. 17

⁹⁰ *Ibid.*; p. 17

⁹¹ „Freiwillige Zielvereinbarung bei der Energie-Agentur der Wirtschaft (EnAW)“

⁹² Schweizer Bundesamt für Umwelt (BAFU), Schweizer Bundesamt für Energie (BFE) (2008); p. 17

Double counting

The problem of double counting in Switzerland is slightly different from that in the French or German schemes. In France or Germany, most projects to promote efficient electricity use or electricity production from renewables lead to an unjustified release of GHG-certificates in the power-generating sector. As the Swiss electricity-generating sector de facto does not emit greenhouse gases⁹³, such projects would not reduce GHG emissions in the electricity-generating sector and therefore do not lead to double counting. The problem of double counting in Switzerland is rather related to the production of heat: If DOPs deliver heat to facilities, which have agreed on GHG emission targets in order to be exempted from paying the CO₂-charge, these facilities have to prove that no GHG emission reductions are counted twice⁹⁴.

4.4 THE NEW ZEALAND DOP-SCHEME

New Zealand’s greenhouse gas (GHG) emission structure is dominated by agriculture to a high extent. In addition, the sectors transport and energy industries are responsible for a relatively high share of New Zealand’s GHG emissions⁹⁵ as demonstrated in Figure 8.

Figure 8 Breakdown of New Zealand emissions by sector and in the energy sector (2007)

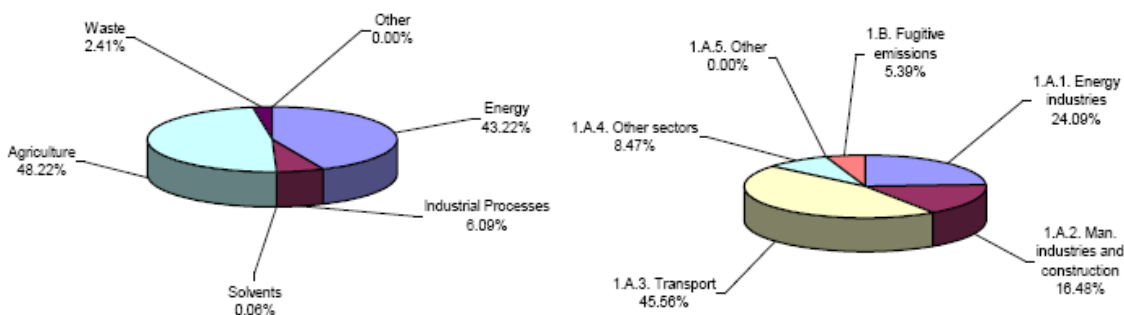

Source: UNFCCC⁹⁶

The emission trend in New Zealand shows a clear picture: greenhouse gas emissions are increasing in almost all sectors, except GHG emissions from waste that have plummeted in the period 1990-2007 (see Figure 9).

⁹³ The Swiss electricity is mostly generated by nuclear power plants. Electricity generated by gas fired plants have to offset 100% of their emissions

⁹⁴ Schweizer Bundesamt für Umwelt (BAFU), Schweizer Bundesamt für Energie (BFE) (2008); p. 17

⁹⁵ See ANNEX III: Specification of emitting sources

⁹⁶ http://unfccc.int/files/ghg_emissions_data/application/pdf/nzl_ghg_profile.pdf; November 27, 2008

Figure 9 Change in New Zealand greenhouse gas emissions 1990-2007 (in %)

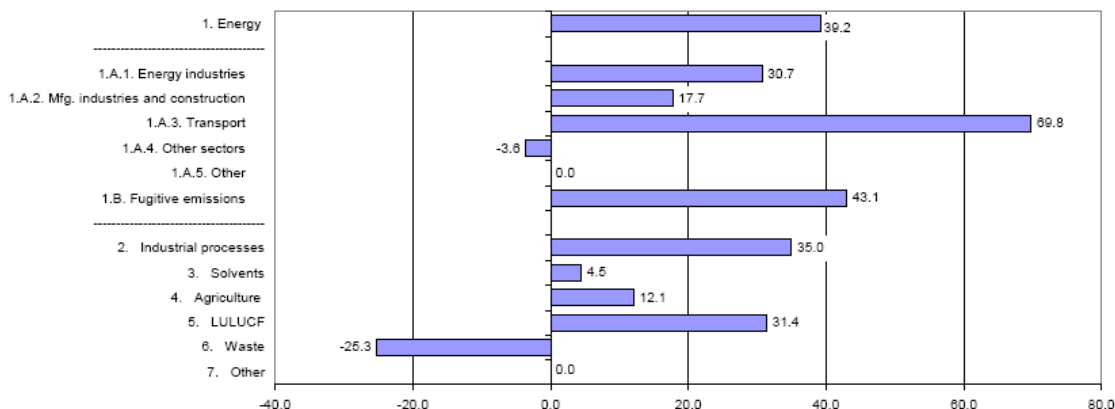

Source: UNFCCC ⁹⁷

According to the Kyoto Protocol, New Zealand has to keep its GHG emissions between 2008 and 2012 on average at the level of its GHG emissions in 1990⁹⁸. Within the period of interest – namely from 2003 till 2004 where a DOP-scheme was introduced – New Zealand faced a gap between real GHG-emissions and its Kyoto-target. However, New Zealand expected to achieve the Kyoto-target due to the absorption capacity of its forests.

Institutional framework

Currently New Zealand has implemented a national emission trading scheme. In the period of interest 2003 to 2004 no emission trading scheme was into force. However, at this time, GHG emissions of certain polluters have been stimulated to be reduced by so-called “Negotiated Greenhouse Agreements”.

DOP-mechanism

Within the period 2003 to 2004 the introduced DOP-scheme was called “Projects to Reduce Emissions (PRE) programme”. The PRE comprised two calls for project proposals in 2003 and 2004⁹⁹. In principle, the Crown transferred AAUs to project participants, the certifying procedure oriented on JI. If all eligibility criteria for Joint Implementation projects were met, the project participant could notify the Crown that ERUs (Emission Reduction Units) were transferred.¹⁰⁰ For that the project participant could chose between the certification procedure JI track 1 and the more complex JI track 2¹⁰¹.

⁹⁷ http://unfccc.int/files/ghg_emissions_data/application/pdf/nzl_ghg_profile.pdf; November 27, 2008

⁹⁸ http://unfccc.int/ghg_data/kp_data_unfccc/base_year_data/items/4354.php; November 27, 2008

⁹⁹ De Dominicis (2005); p. 4

¹⁰⁰ <http://www.mfe.govt.nz/issues/climate/policies-initiatives/projects/questions-answers.html>; November 10, 2009

¹⁰¹ <http://www.mfe.govt.nz/issues/climate/policies-initiatives/joint-implementation/index.html>; December 10, 2008

Supporting factors and motivation

The supporting factor and motivation for introducing this instrument was to achieve GHG-additional reductions of 4 mio. tonnes and 6 mio tonnes CO₂eq¹⁰² within the time period 2008 to 2012. The intention was also to achieve this via “economic instruments” rather than “subsidies or regulatory interventions”¹⁰³.

Implications for achieving national GHG abatement targets

For real GHG abatements within the PRE programme the New Zealand government either issued AAUs or ERUs, which are backed-up by AAUs. This means on the one hand, the New Zealand government cannot use any more respective amounts of AAUs for their Kyoto-compliance. On the other hand, real GHG emissions were reduced by the same extent. Keeping in mind potential but not detectable non-additionality of some projects, project developers received less credits than would have been justified by the real GHG abatements induced by their DOPs. This did not work only as a risk premium against non-additionality of projects, but also to reduce GHG emissions more than AAUs are lost for governmental Kyoto-compliance. Assuming strict additionality, the PRE programme did not cause a widening of New Zealand’s Kyoto-gap. For achieving GHG abatement targets in the long run, this programme was helpful as GHG abatements remain, but no AAUs have to be issued for that in subsequent compliance periods.

Sectors

In order to choose from a remarkable pool of projects, the New Zealand PRE intended a wide range of “potential involvement of different sectors”¹⁰⁴. Project developers could submit project proposals in all areas¹⁰⁵ (e.g., agriculture, forestry, energy efficiency, transport, bio-energy) as long as induced GHG emission reductions were recordable by the national inventory¹⁰⁶. Furthermore, all six Kyoto-gases¹⁰⁷ were considered eligible for domestic GHG reduction projects under this DOP-scheme. “Projects related to the sequestration of CO₂, in forest or soil sinks”¹⁰⁸, however, were considered non-eligible.

Administrative procedures

The PRE programme was executed by two calls for tenders. Interested project developers had to submit their project ideas, anticipated amounts of GHG-reductions and demanded carbon offset credits for their GHG abatements. From submitted project proposals the

¹⁰² <http://www.mfe.govt.nz/issues/climate/policies-initiatives/joint-implementation/index.html> ;pp. 5/6

¹⁰³ Jamieson et al. (2005): p. 3 ; Their definition of economic instruments : “An economic instrument generally takes either of two main forms – an externality (often called “Pigovian)tax which puts a predetermined price on emissions or a cap-and-trade system in which the total allowable emissions are determined in advance, and the price paid will depend on the cost of abatement to reach that target”

¹⁰⁴ <http://www.mfe.govt.nz/issues/climate/policies-initiatives/projects/questions-answers.html> ; December 10, 2008

¹⁰⁵ *Ibid.*

¹⁰⁶ De Dominicis (2005);p. 4; also <http://www.mfe.govt.nz/issues/climate/policies-initiatives/projects/eligibility-selection.html> ; December 10, 2008

¹⁰⁷ CO₂, CH₄, N₂O, HFCs, PFCs, SF₆

¹⁰⁸ De Dominicis (2005); p. 4

government has chosen those which provided most GHG abatements for requested offset credits.¹⁰⁹ This means, the government selected projects according to the ratio of the number of emission units requested by the tenderer divided by the tons of CO₂eq emissions expected to be reduced by the project during the first commitment period of the Kyoto-protocol (2008-2012). As not all submitted projects could be chosen, this provision led to a competing environment for project developers in order to not overstate their demand for offset credits in relation to expected GHG abatements.

Once chosen from the portfolio of submitted and additional (!) project proposals, the procedure for generating DOP-credits was similar to other schemes: project implementation, GHG abatement measuring, reporting and verification. After that, the New Zealand government issued AAUs, and – if demanded and eligible – also ERUs¹¹⁰.

In order to reach an economically attractive ratio between revenues from the sale of DOP-credits and transaction costs, the New Zealand DOP-scheme required a minimum of 10,000 tons¹¹¹ mitigated GHG emissions per DOP over the entire Kyoto-period (2008-2012).

Another provision to minimize transaction costs for project developers is the fact that the New Zealand government bears the costs for verifying emission reductions. Furthermore, no fees were requested for “including additional project participants, withdrawing project participants or approving a JI project”¹¹².

Compatibility with governmental subsidies

Regarding the compatibility of stating GHG emission reduction projects as DOPs as well as asking for governmental grants for the same projects, the PRE-regime guidelines did not explicitly restrict this opportunity. However, as the certification procedure of DOPs was oriented or based on JI, project developers were forced to prove that governmental subsidies alone would not have been sufficient for the project realization.

Additionality

Additionality of projects was a highly important element as issued credits from PRE resulted in a transfer of AAUs. Therefore, high attention was paid to the additionality of submitted project proposals. Project proposals had to undergo, first, an “investment assessment to confirm that they are additional to business as usual” and, second, an “environmental assessment to determine the level of emission reduction beyond business as usual”¹¹³. In order to minimize the risk of widening the Kyoto-gap because of a possible fraction of non-additional projects, DOP developers received less credits from the government than actually justified by projects induced GHG emission reductions (as mentioned above). This can be considered – de facto – as discounting of DOP-credits. The discount can be seen as a

¹⁰⁹ The government took also the anticipated risks into consideration, that projects fail to deliver planned GHG emission reductions. This risk assessment included “any risk associated with the project owner, the project technology, the project resources and the project economics”, <http://www.mfe.govt.nz/issues/climate/policies-initiatives/projects/eligibility-selection.html> ; December 9, 2008

¹¹⁰ <http://www.mfe.govt.nz/issues/climate/policies-initiatives/projects/questions-answers.html> ; November 28, 2008

¹¹¹ <http://www.mfe.govt.nz/issues/climate/policies-initiatives/projects/eligibility-selection.html> ; December 9, 2008

¹¹² New Zealand Ministry for the Environment (2008); p. 6

¹¹³ <http://www.mfe.govt.nz/issues/climate/policies-initiatives/projects/eligibility-selection.html> ; December 10, 2008

general insurance fee against the risk of having some non-additional projects. It is worth to mention that this kind of discount fee determination seems very practical from a regulatory point of view: not the regulator had to determine the discount rate, but it was done by the market due to the competition of market players.

Also, a crucial question regarding additionality was the definition of boundaries between voluntary actions and PRE-induced actions. Industries which have signed the voluntary “Negotiated Greenhouse Agreement” (NGA) could participate – in principle – in the PRE-scheme¹¹⁴. However, “a project may not contribute to the firm’s efforts to meet its obligations under the NGA – it must be clearly outside the NGA boundary or additional to the NGA commitments”¹¹⁵.

Double counting

Furthermore, high attention was paid to the issue of double counting of GHG abatement merits. The New Zealand PRE included in its eligibility criteria a requirement for a ‘no double dipping’ principle such that firms that have an NGA cannot use support from the PRE programme to help in meeting their NGA commitments”¹¹⁶.

4.5 DOPS IN THE REGIONAL GREENHOUSE GAS INITIATIVE (OF THE U.S.)

So far, the United States of America have not implemented joint actions on a federal level to combat climate change. However, within the U.S. several initiatives have emerged to tackle this issue.

In the U.S., more than 86 % of GHG emissions arise from the energy sector. This is shown in Figure 10¹¹⁷.

¹¹⁴ In the first tender, firms in the process of negotiating an NGA could not participate at all. Starting with the second tender, if there were clearly defined activities or parts of the firm that were not covered by the NGA application, or were deemed ineligible for NGA coverage, then projects relating to these activities could be submitted into a tender round; Jamieson et al. (2005); December 10, 2005.

¹¹⁵ Jamieson et al. (2005); p. 9

¹¹⁶ *Ibid.*, p. 14

¹¹⁷ See ANNEX III: Specification of emitting sources

Figure 10 Breakdown of U.S. emissions by sector and in the energy sector (2007)

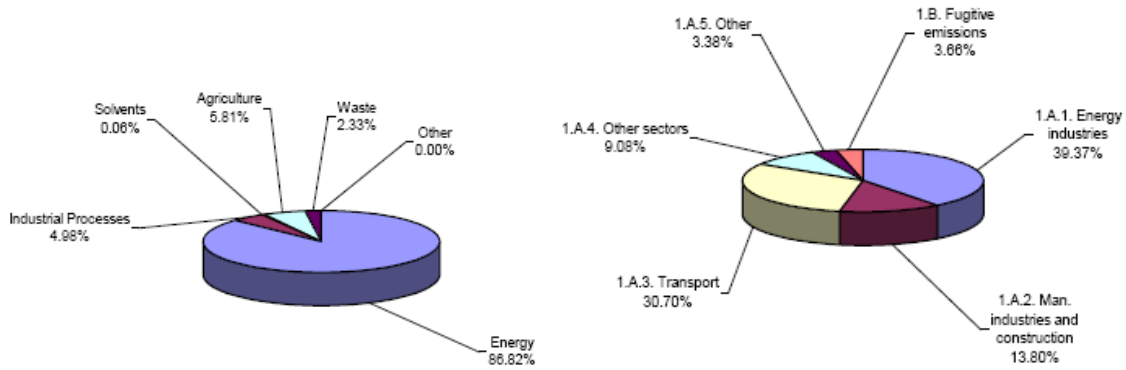

Source: UNFCCC¹¹⁸

The emissions trend in the period 1990-2007 shows a sharp increase of GHG emissions in the energy industries and the transport sector. Considerable emission cuts were achieved in the area of fugitive emissions and in the waste sector.

Figure 11 Change in U.S. greenhouse gas emissions 1990-2007 (in %)

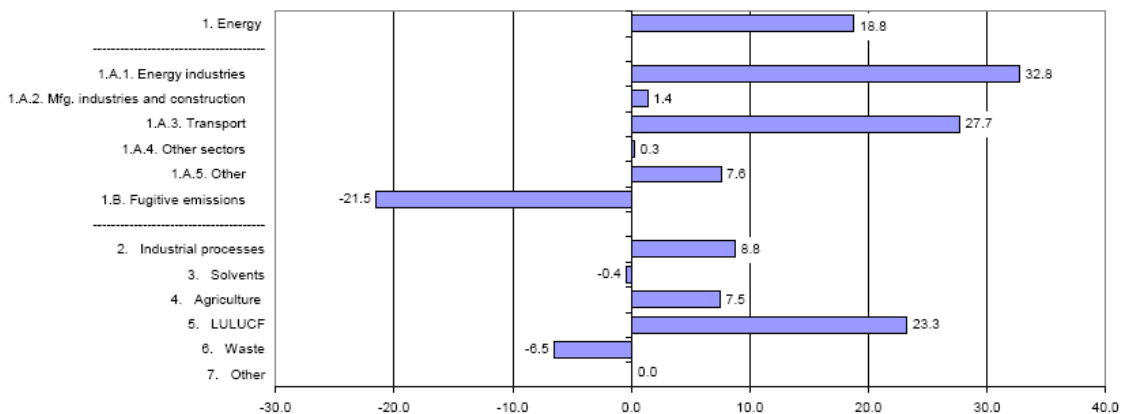

Source: UNFCCC¹¹⁹

According to the Kyoto Protocol, the US agreed to lower their GHG emissions by 7 % compared to 1990. However, the US did not ratify the Kyoto Protocol. The current GHG emissions level is approximately 16 %¹²⁰ above the level of 1990.

Institutional framework

Within the United States, the Northeast and Mid-Atlantic States Connecticut, Delaware, Maine, Maryland, Massachusetts, New Hampshire, New Jersey, New York, Rhode Island,

¹¹⁸ http://unfccc.int/files/ghg_emissions_data/application/pdf/usa_ghg_profile.pdf; May 6, 2010

¹¹⁹ *Ibid.*

and Vermont¹²¹ have united their efforts to combat climate change. The Regional Greenhouse Gas Initiative (RGGI) is the first mandatory and market-based CO₂-emissions reduction scheme in the U.S. These federal states have set up an emissions trading scheme (ETS), by capping¹²² “CO₂ emissions from the power sector (generators of 25 MW or greater¹²³), and then requiring a ten percent reduction in these emissions by 2018”¹²⁴.

DOP mechanism

In contrary to other countries and regions, DOPs in the RGGI-system are not based on the flexible mechanisms of the Kyoto-protocol. As the U.S. have not ratified the Kyoto-protocol, domestically generated carbon offset certificates cannot be developed under JI (Joint Implementation). However, the RGGI scheme has developed own guidelines to generate DOPs.¹²⁵

Supporting factors and motivation

The main supporting factor for including offsets in the RGGI-scheme was to provide some flexibility to capped installations for their compliance as well as to increase economic efficiency of GHG-reduction.¹²⁶

Implications for achieving national GHG abatement targets

The U.S. have not defined a national GHG abatement target so far. Intending to achieve GHG-reductions in the energy industry sector only a strict DOP-scheme guarantees the environmental integrity of the corresponding ETS.

Sectors

As of December 2008, only five different project categories¹²⁷ were eligible to generate carbon offsets:

- Landfill methane capture and destruction
- Reduction in emissions of sulfur hexafluoride (SF6)
- Sequestration of carbon due to afforestation
- Reduction or avoidance of CO₂ emissions from natural gas, oil, or propane end-use combustion due to end-use energy efficiency in the building sector
- Avoided methane emissions from agricultural manure management operations

¹²⁰ UNFCCC (2009), p. 9

¹²¹ <http://www.rggi.org/states> ; December 15, 2008

¹²² Capping in this context means to “stabilize power sector CO₂-emissions over the first six years of program implementation (2009-2014)” at a level roughly equal to emissions of 2007; compare RGGI [2] (2007); p. 2

¹²³ RGGI [2] (2007); p. 2

¹²⁴ <http://www.rggi.org/about> ; December 15, 2008

¹²⁵ RGGI [1] (2007); p 96 et seq.

¹²⁶ *Ibid.*; p. 9

¹²⁷ RGGI [2] (2007); p. 9

The RGGI does not restrict the use of offsets to offsets generated in its own territory: “Eligible offset projects may be located in any participating state, or any other state or U.S. jurisdiction in which a cooperating regulatory agency has entered into a MOU with the participating states to provide oversight support related to CO₂ emissions offset projects in that state or U.S. jurisdiction”¹²⁸.

Administrative procedures

The application process to generate offset projects is a two-step procedure, similar to schemes analyzed before: “The first step is a consistency determination, whereby the applicable regulatory agency would determine whether a project meets the eligibility criteria”¹²⁹. This step includes the check whether submitted project proposals can be classified into one of the five eligible project types mentioned before, whether projects are additional to BAU, or whether projects are permanent. The second step occurs after the project implementation: it is “the submittal of an annual monitoring and verification report, which requires the applicant to demonstrate the precise amount of greenhouse gas emissions reduced or sequestered before offset allowances are awarded.”¹³⁰

To minimize costs and risks faced by project developers, RGGI has predefined methodologies for procedures to generate offset certificates. To enlarge the portfolio of eligible project types, “the participating states intend to develop methodologies for evaluating new categories of offset projects”¹³¹. Also, as eligible project-types are defined beforehand, project developers face lower risks of submitting proposals of project-types which turn out to be ineligible afterwards.

Compatibility with governmental subsidies

The Regional Greenhouse Gas Initiative model rule explicitly states that “CO₂ offset allowances shall not be awarded to an offset project that receives funding or other incentives from any system benefit fund, or funds or other incentives ...,”¹³² so it cannot be combined with other public support measures.

Additionality

To ensure the environmental integrity of the RGGI-system, strict additionality is required. Besides financial additionality, the RGGI model rule also emphasizes the importance of regulatory additionality of offset projects as a key component. Offset projects are regulatory additional if they are not required by law or other directives.

Furthermore, the RGGI model rule excludes offset projects that generate offset allowances “under any other mandatory or voluntary greenhouse gas program”¹³³.

¹²⁸ RGGI [2] (2007); p. 9

¹²⁹ *Ibid.*, p. 10

¹³⁰ *Ibid.*

¹³¹ *Ibid.*, p. 9

¹³² RGGI [1] (2007); p. 107

¹³³ *Ibid.*

Double counting

As the Regional Greenhouse Gas Initiative caps GHG emissions of the power sector, generating DOP-credits by promoting “green electricity” would lead to the notorious indirect double counting problem with released allowances from the power sector. Promoting the usage of renewable energies seems wise in the context of GHG mitigation, however, “in a capped environment, the development of new renewable electric generation facilities does not necessarily reduce the emissions of carbon dioxide associated with electric generation. This is because the production of electricity by non-carbon emitting sources does not lower the cap and the number of allowances available.”¹³⁴ Therefore, the RGGI model rule does not allow offset projects “that include an electric generation component, unless the project sponsor transfers legal rights to any and all attribute credits generated from the operation of the offset project that may be used for compliance with a renewable portfolio standard or other regulatory requirement, to the regulatory agency or its agents”¹³⁵.

Nevertheless, the RGGI itself includes a provision to stimulate the production of green electricity, like the “Allowance Retirement for Voluntary Renewable Energy Purchases”¹³⁶.

4.6 DISCUSSED DOP-SCHEME IN THE NETHERLANDS

In the Netherlands currently no DOP-scheme is introduced. However, discussions about a potential introduction are ongoing. Therefore, the cornerstones of a potential Dutch DOP-scheme are presented shortly.

The Dutch *Foundation Joint Implementation Network (JIN)* has proposed a DOP-scheme with the following cornerstones: The certification procedure of a Dutch DOP-scheme could be based on JI track 1. Due to rather long lead times necessary for implementing GHG-abatement projects based on JI (writing a project design document, approval of authorities etc.) an introduction still within the Kyoto-period 2008-2012 will not be attractive for potential project developers. Therefore, it is proposed by JIN that a Dutch DOP-scheme comes into force from 2013. Furthermore, it is proposed that Domestic Offset Projects should be eligible in all sectors as long as projects fulfill the requirement of additionality and avoid double counting.

In the past, the Netherlands purchased carbon offset credits from CDM-projects. Best price conditions were ensured by the call for bids called ERUPT, where international developers of carbon offset credits were competing against each other. This gives an incentive for keeping sales prices as low as possible. The same idea was proposed for a Dutch DOP-scheme: Thereby the government could call for Domestic Offset Projects and purchasing offset credits until a certain price and quantity threshold. In that case the government would be the buyer of generated credits.

¹³⁴ RGGI [1] (2007); p. 107

¹³⁵ *Ibid.*, p. 106

¹³⁶ See RGGI [2] (2007) for further details; p. 5

4.7 SYNTHESIS OF FINDINGS

The analysis of different schemes showed the variety of design options DOP-schemes may have. In the following section, important characteristics of analyzed schemes will be pointed out and comparisons will be made between different schemes. First, exogenous characteristics (institutional frameworks and trend of GHG emissions) influencing the designs of DOP-schemes are shown. This is followed by a listing of characteristics of DOP-schemes which are derived from the analyses in the previous subsections.

The following aspects will be included:

- Extent of a Kyoto-gap
- Distribution of GHGs among sectors
- Trends of GHG emissions in various sectors
- Project-types eligible and non-eligible for Domestic Offset Projects
- System for certifying credits of DOPs
- Administrative procedure to generate offsets
- Provisions to ensure additionality of DOPs
- Provisions against net-transfer of AAUs
- Provisions to avoid double counting
- Incompatibilities of DOPs with governmental subsidies
- Provisions to keep transaction and administration costs low

4.7.1 Extent of the Kyoto-gap

The so-called Kyoto-gap is the difference between a ratifying country's real GHG emissions and its budget of AAUs when the latter is lower than the former. The magnitude of its Kyoto-gap determines a country's required efforts to mitigate GHG emissions.

Table 1 shows that all considered countries either had an obligation to reduce their GHG emissions or to keep GHG emissions constant to 1990 levels. It turns out that DOPs were implemented not only in countries which have already – from the current point of view – fulfilled their GHG abatement obligations. Also countries which have not fulfilled their GHG abatement requirements have introduced DOP-schemes.

Table 1 Greenhouse gas emissions and anticipated achievement of Kyoto-targets with domestic actions

	France	Germany	Switzerland	New Zealand	USA/RGGI*
GHG emissions of base year 1990 (Mio.t.) (excluding emissions/ removals from LULUCF)	564	1,232	53	62	6,229
Reduction commitment	0%	-21%	-8%	0%	-7%
Eligible GHG emissions (Kyoto-commitment)	564	974	49	62	5,793
Facing currently a Kyoto-gap (foreign offset sales excluded)?	No	No	Yes	Yes	n.s.

Source: UNFCCC¹³⁷, own calculations (*data of GHG emissions, targets and trends of the United States; n.s. not specified)

Conclusion: The instrument of DOPs was introduced also by countries which currently face a Kyoto-gap.

4.7.2 Distribution of greenhouse gases among sectors

Knowing the structure of GHG emissions of an economy is very important in knowing which sectors face the highest leverage for achieving a country's GHG emission targets.

In Table 2 respective shares of GHG emissions per sector are shown according to the classification of the United Nations Framework Convention on Climate Change (UNFCCC)¹³⁸. The data are displayed without considering "Land use, land use change and forestry" (LULUCF).

Table 2 Share of greenhouse gases per sector (2007)

Segmentation of GHG emissions in %	France	Germany	Switzerland	New Zealand	USA/RGGI*
ENERGY	72.36	80.92	81.86	43.22	86.82
Energy industries	17.55	50.37	8.25	24.09	39.37
Man. Industries and construction	20.57	11.64	13.96	16.48	13.80
Transport	35.64	19.80	38.95	45.56	30.70
Other sectors	24.77	16.62	36.76	8.47	9.08
Other	0.00	0.17	1.42	0.00	3.38
Fugitive emissions	1.47	1.40	0.66	5.39	3.66
INDUSTRIAL PROCESSES	7.53	12.15	5.97	6.09	4.98
SOLVENTS	0.25	0.35	0.45	0.06	0.06
AGRICULTURE	17.97	5.38	10.43	48.22	5.81
WASTE	1.88	1.20	1.29	2.41	2.33
OTHER	0.00	0.00	0.00	0.00	0.00

Source: UNFCCC¹³⁹ (* share of GHG emissions corresponding to the United States)

¹³⁷ http://unfccc.int/ghg_data/kp_data_unfccc/base_year_data/items/4354.php ; November 27, 2009 (for lines 1 and 2), own calculations (for line 3 and 4)

¹³⁸ See also ANNEX III: Specification of emitting sources

¹³⁹ http://unfccc.int/ghg_emissions_data/ghg_data_from_unfccc/ghg_profiles/items/3954.php ; November 27, 2009

The table above shows for France that a considerable share of GHG emissions is not covered by the EU-ETS – for instance transport, “other sectors”¹⁴⁰ and agriculture. In contrast, Germany’s GHG emissions are covered by the EU-ETS to a wide extent. However, also fuel combustion emissions from transport and “other sectors” count for an extent worthwhile to further reduce GHG emissions in these sectors. Also in Switzerland, fuel combustion emissions from transport and “other sectors” as well as process related GHG emissions from agriculture are considerable. At the time of the PRE¹⁴¹, New Zealand’s main emitting sectors have been agriculture (process emissions) as well as transport and energy industries (fuel combustion emissions). The main emitting source in the U.S. is the sector energy industries, whose GHG emissions are capped within the RGGI region. A considerable emitting source is also the transport sector not covered by the RGGI regime.

Conclusion: The structure of GHG-emissions shows that considerable fractions of GHG-emissions are not capped. Therefore, effective pollution control instruments are necessary to ensure that GHG-emissions not capped by any scheme get reduced economically most efficient.

4.7.3 Trends of GHG emissions in various sectors

Table 3 shows GHG emission trends of considered countries. Looking on this table shows where pollution control instruments lead to desired results (reducing GHG emissions), keeping in mind that all considered countries have to reduce their GHG emissions or keep them constant to the level of the base year 1990 respectively.

Table 3 Trends of greenhouse gases per sector in the period 1990 - 2007

Change of GHG emissions 1990-2007		France	Germany	Switzerland	New Zealand	USA/RGGI*
ENERGY		+0.3	-21.7	-0.3	+39.2	+18.8
Energy industries		+1.5	-7.1	+36.0	+30.7	+32.8
Man. Industries and construction		-10.7	-42.3	-2.6	+17.7	+1.4
Transport		+15.4	-6.9	+10.7	+69.8	+27.7
Other sectors		-3.0	-38.2	-13.3	-3.6	+0.3
Other		0.0	-89.3	+32.5	0.0	+7.6
Fugitive emissions		-51.2	-60.9	-46.9	+43.1	-21.5
INDUSTRIAL PROCESSES		-28.4	-3.1	-6.1	+35.0	+8.8
SOLVENTS		-33.9	-38.5	-50.7	+4.5	-0.4
AGRICULTURE		-11.0	-16.5	-9.4	+12.1	+7.5
WASTE		-16.7	-71.5	-33.3	-25.3	-6.5
OTHER		0.0	0.0	0.0	0.0	0.0
strong decrease (> -10%)	intermediate decrease (-10% - -2%)	slight decrease (-2% - 0%)	constant emissions	slight increase (0% - 2%)	intermediate increase (2% - 10%)	strong increase (> 10%)

Source: UNFCCC¹⁴² (*trends of GHG emissions of the United States)

¹⁴⁰ Commercial/institutional, residential, agriculture/forestry/fisheries GHG emissions from fuel combustion

¹⁴¹ New Zealand’s DOP-scheme

¹⁴² http://unfccc.int/ghg_emissions_data/ghg_data_from_unfccc/ghg_profiles/items/3954.php ; November 18, 2008

Table 3 shows for France that especially transport's GHG emissions were sharply rising in the time period 1990-2007 (Transport is not included in the EU-ETS). In Germany, all emitting sectors had decreasing GHG emissions within the period of consideration. Switzerland faced high GHG emission increases in energy industries, in the sector "other"¹⁴³ but also in the sector transport – which demands for more effective instruments for reducing GHG emissions (transport and "other"¹⁴⁴) or offsetting (energy industries) them. New Zealand and the U.S./RGGI both show a picture which demands for effective pollution control instruments in most sectors.

Considering the specific countries' overall GHG emission trends shows a development depicted in Table 4:

Table 4 Trends of greenhouse gases per country in the period 1990 – 2007 (excl. LULUCF)

	France	Germany	Switzerland	New Zealand	USA/RGGI*
Change of GHG emissions 1990-2007	-5.3	-21.3	-2.7	+22.1	+18.8

Source: UNFCCC (2009)¹⁴⁵ (*trends of GHG emissions of the United States)

France has decreased steadily its GHG emissions by more than 5 % within the period 1990-2007. Keeping in mind that France agreed to keep its GHG emissions constant to the level of 1990, it would not be forced to take additional efforts for achieving its Kyoto-target.

The same is true for Germany, which slightly over fulfilled its obligations for GHG abatements (from the current point of view). The decrease in GHG emissions was achieved steadily.

Switzerland currently faces a Kyoto-gap, as it did not face a steady decrease in GHG emissions.

New Zealand faces a high increase of GHG emissions within the period of consideration. However, at the time when the PRE was introduced, the government expected to achieve its GHG-targets anyway due to the adsorption capacity of its forests.

Also the U.S. has not reduced GHG-emissions on the level previously promised¹⁴⁶. However, regional initiatives as RGGI target a reduction of GHG-emissions – DOPs are intended to assist achieving these targets at lowest costs.

It can be anticipated that the financial crisis (started in 2007) may induces sustainable decreases in GHG-emissions within the Kyoto-compliance period, whereas emissions covered under an ETS may react more flexible to changed economic conditions than emissions not covered by an ETS.

Conclusion: This sectoral consideration shows that sectors which have been chosen for DOPs face partly considerable increases in GHG-emissions. For EU-member states this is

¹⁴³ GHG emissions from fuel combustion not specified elsewhere, includes also military fuel use. See for classification ANNEX III: Specification of emitting sources

¹⁴⁴ GHG emissions from fuel combustion not specified elsewhere, includes also military fuel use

¹⁴⁵ <http://unfccc.int/resource/docs/2009/sbi/eng/12.pdf>; November 29, 2009

¹⁴⁶ Finally the U.S. have not ratified the Kyoto-protocol

mainly the transport sector. In Non-EU countries also energy induced GHG-emissions from energy industries and manufacturing industries & construction as well as emissions from industrial processes and agriculture faced a considerable increase in the past which made additional incentives for GHG-reduction in these sectors necessary.

4.7.4 Project- types eligible and non-eligible for Domestic Offset Projects

Analyzed DOP-schemes offered a wide range of project-types where DOPs could be implemented. In most cases, they only exclude facilities already covered by a corresponding ETS.

Table 5 Sectors which are generally eligible for generating DOPs

	France	Germany	Switzerland	New Zealand	RGGI
Industrial processes (not covered by any corresponding ETS) and manufactories	X	X	X	X	
Power plants (not covered by any corresponding ETS)		X	X	X	X
Households	X	X	X	X	X
Transport	X	X	X	X	
Agriculture	X	X	X	X	X
Waste		X	X	X	X
Miscellaneous		X	X	X	

Source: own depiction based on sections 4.1 - 4.5

Some countries have specified within certain sectors, which GHG-abatement projects could be accepted as Domestic Offset Projects (as France, Switzerland and USA/RGGI). Others however, as Germany and New Zealand, have only defined appropriate sectors for DOPs without further restraints.

Table 6 Project-types eligible for DOPs

Affected sector	Project type	F	G	CH	NZ	RGGI
Industrial processes			X		X	
	Flaring of GHG which are emitted by industrial processes	X				
	Usage and avoiding of waste heat of industrial processes			X		
	Change of fossil fired heat and electricity production to low- or zero emissions production processes			X		
Power Plants			X		X	
	Usage and avoiding of waste heat of electricity plants			X		
	Reduction of emissions of SF6 in the electric power sector					X
Households			X		X	
	Heat production which reduces fossil fuel consumption (firing of biomass, usage of heat pumps, solar energy)	X		X		
	More efficient usage of waste heat by consumers			X		
	Optimization of specific facilities			X		
	Reduction or avoidance of CO2 emissions from natural gas, oil or propane end-use combustion due to end-use energy efficiency in the building sector					X
Transport			X		X	
	Efficiency improvement in passenger and goods transportation (traffic relocation and reduction)			X		
Agriculture			X		X	
	Methane capture from agricultural processes	X				
	Production of biogas and biomass			X		
	Avoiding and substitution of N2O			X		
	Manure management					X
	Afforestation/ Reforestation, forest management, forest preservation/ conservation, forest products					X
Waste			X		X	
	Usage of bio-waste to generate biogas for substitution of natural gas in the transport sector	X				
	Flaring and energetic use of excessive methane			X		
	Landfill methane capture and destruction					X
Miscellaneous			X		X	
	Reduction of HFC emissions of commercial cooling and in the food production sector	X		X		
	General avoiding and substitution of F-gases			X		

Source: own depiction based on sections 4.1 - 4.5 (F=France; G=Germany; CH=Switzerland; NZ=New Zealand; RGGI=Regional Greenhouse Gas Initiative)

All analyzed schemes have explicitly stated certain types of projects which are not accepted for generating credits by DOPs. Reasons for restrictions are mostly overlaps with other pollution control instruments, as emission trading schemes for example (problem of double

counting). Furthermore, project-types are sometimes not accepted if their implementation impedes other policy targets (e.g. no nuclear power). Also they exclude soft measures as well as measures which are already forced by legal provisions. Obviously, a pure reduction of production/service will not be eligible as DOPs either.

The following table provides an overview of project-types not considered as eligible in analyzed DOP-schemes.

Table 7 *Project-types not eligible for DOPs*

Affected sector	Project type	F	G	CH	NZ	RGGI
Industrial processes						
	Projects affecting GHG emissions in capped industries	X	X			
Power Plants						
	Projects affecting GHG emissions of the electricity supply sector	X	X			X
	Nuclear energy projects			X		
Households						
Transport						
	Production of liquid biofuels	X		X		
Agriculture						
	Biologic and geologic carbon sequestration (afforestation, reforestation, agriculture, carbon capture and storage)	X		X	X	
	Reduction of fertilization in agriculture	X				
Waste						
Miscellaneous						
	Climate research and development, consulting and information dissemination	X	X	X		

Source: own depiction based on sections 4.1 - 4.5 (F=France; G=Germany; CH=Switzerland; NZ=New Zealand; USA/RGGI=Regional Greenhouse Gas Initiative)

Conclusion: In principle, all those sectors (or parts of sectors) are eligible for DOPs which are not capped by an ETS. However, in individual cases the precise design is highly diverse. In many cases or entirely excluded for DOPs are “soft measures”, carbon capture and storage activities or measures which cause double counting of GHG-emission reductions in ETS-sectors respectively.

4.7.5 System for certifying credits of DOPs

The efforts and procedures for certifying Domestic Offset Projects depend on the subsequent use of generated allowances. If DOP-credits should be used for international compliance purposes, credits have to fulfill certain international quality standards. For example, credits are internationally recognized if they satisfy the quality requirements to Joint Implementation (JI) projects.

However, if credits are intended to be used in a purely national scheme, the quality of generated credits has to fulfill only quality standards demanded by the corresponding national scheme.

Therefore, the certification procedures for DOPs credits are classified into the internationally accepted Joint Implementation certification and other national certification procedures, as summarized in the following table.

Table 8 *Classification of certification procedures for allowances of DOPs*

	France	Germany	Switzerland	New Zealand	RGGI
Joint Implementation certification (Track1 or Track2)	X	X		X	
Other national certification			X	X	X

Source: own depiction based on sections 4.1 - 4.5

Conclusion: It turns out that the DOP-schemes in France and Germany require Joint Implementation certification. New Zealand's DOP-scheme required certification according to national rules – however, also Joint Implementation certification was possible to be applied. Switzerland and RGGI apply national rules as generated credits are not intended for international compliance use.

4.7.6 Administrative procedure to generate Offsets

The procedures to generate domestic offsets of particular countries follow similar rules. It is common in most schemes that a project starts with submitting a pre-proposal or proposal to communicate the project developers' intentions.

In general, the next step is the validation of projects: this validation process tests – for instance – whether intended projects are implemented additionally to a business-as-usual (BAU) scenario. This is necessary to find out whether revenues from offset credits' sales are really necessary to enable a project of being implemented and rather than acting as a 'nice' co-funding for GHG-mitigation measures implemented anyway ("additionality"). Furthermore, the validation process might test whether the generation of offset-credits also leads to a release of credits from facilities capped under an emissions trading scheme (double counting problem).

After the project is considered as eligible and is implemented, the project's GHG emission reductions are measured. This implies certain administrative efforts such as monitoring GHG

emission reductions before and after the project implementation, reporting them to responsible authorities and verifying these GHG emission reductions statements by an independent verifier. After this monitoring/ reporting/ verifying (MRV) process, offset credits are allocated to project developers.

Table 9 Administrative procedures to generate credits from Domestic Offset Projects

	France	Germany	Switzerland	New Zealand	RGGI
Submission of a project pre-proposal		X	X		
Submission of project proposal (Registration)	X	X	X	X	X
Program bids round				X	
Project validation (additionality test, double counting barriers) before implementing the measure	X	X	X	X	X
Implementing the offset measure	X	X	X	X	X
Project monitoring/ reporting/ verifying after implementing the measure	X	X	X	X	X
Crediting of offset certificates	X	X	X	X	X
Generation of ERUs	X	X		possible	

Source: own depiction based on sections 4.1 - 4.5

Conclusion: The generating procedures for offset credits are largely similar among countries and schemes.

4.7.7 Provisions to ensure additionality of DOPs

Additionality of Domestic Offset Projects is a key element of DOP-schemes. The importance of this key-element arises for the following reason: considering non-additional GHG mitigation projects as offset projects might decrease a country's budget of AAUs¹⁴⁷ without decreasing the country's real GHG-emissions to the same extent. This would widen a certain gap between AAUs available and real GHG emissions.

Domestic Offset Projects are additional if they would not have been accomplished without revenues from credits sales. These revenues should ensure that projects pay off in an appropriate period of time and/or lead to overcome other barriers.

To ensure additionality of GHG abatement projects, most countries apply widely accepted additionality tests. These additionality tests are supposed to evaluate financial or other barriers that can be overcome only by additional financial funds and can, therefore, justify the generation of sellable carbon offset credits.¹⁴⁸

¹⁴⁷ This would happen if AAUs were issued for reduced GHG-emissions because of DOPs

¹⁴⁸ Compare also with UNFCCC/CCNUCC (2004)

In addition to additionality tests, discounting of the issued amount of credits for DOPs by the government might be one option to ensure that not more offset credits are issued than real greenhouse gases get reduced. This option is justified by the assumption that a certain fraction of the overall DOPs-portfolio might not be additional although strict additionality tests are applied. This uncertainty about the additionality of projects could, therefore, be compensated by a risk premium. In other words, all revenues from DOP-credits could include a risk premium for non-additional projects. This risk premium lowers a project's revenues from DOP-credits' sales.

Analyzed schemes also exclude projects which became realized before the introduction of a DOP-scheme was announced. The rationale behind this is that it is quite likely that projects implemented before the scheme announcement might be profitable anyway, that is, they are profitable without revenues from DOP-credits.

A further element of ensuring additionality is the requirement that facilities must still be ready to operate, i.e. not be broken. This is based on the assumption that broken facilities would be replaced anyway.

Table 10 Provisions to ensure additionality

	France	Germany	Switzerland	New Zealand	RGGI
Additionality tests	X	X	X	X	X
Discounting of credits	X			X	
Exclusion of projects becoming realized at the time of scheme announcement (ignoring short time line before)	X	X	X	X	X
Exclusion of projects already forced by legislation	X	X	X	X	X
Exclusion of projects which only exchange/renew broken facilities	X	X	X	X	X

Source: own depiction based on sections 4.1 - 4.5

Conclusion: All DOP-schemes apply widely accepted additionality tests. Also they apply certain minimum eligibility criteria, for instance that projects are excluded from DOPs if they only exchange/ renew broken facilities. In addition to that, France and New Zealand apply a discounting of issued credits to better avoid residual risk for the case where additionality tests would not entirely filter out all non-additional projects.

4.7.8 Provisions against net-transfer of AAUs

If allowances of DOPs are generated within the framework of JI, selling allowances to abroad would lead also to a transfer of AAUs from the selling country to the purchasing country. However – assuming additionality of all DOPs – the reduction of the host country's AAUs due to the sale of allowances results in a reduction of real GHG emissions by the same extent.

However, as discussed in the subsection before, even strict additionality tests might not completely ensure full additionality of the projects' portfolio. This would result in a net-transfer of AAUs (in schemes where AAUs are transferred at all).

A very important question is now, how countries protect themselves against suffering a loss of AAU without real GHG-reductions by the same amount (AAUs net-transfer). Table 11 shows provisions against a potential net transfer of AAUs: Common to all systems are strict additionality tests, as mentioned above. Some countries are discounting the amount of AAUs they issue for each ton of CO₂ affirmed to be reduced by DOPs. This works like an "insurance premium" against non-additional projects not filtered out despite strict additionality tests. Other systems do not issue AAUs at all – either because they have not ratified Kyoto (USA/RGGI) or generated credits are for domestic use only (Switzerland).

Table 11 Transfer of Assigned Amount Units by selling allowances of DOPs

	France	Germany	Switzerland	New Zealand	RGGI
Strict additionality requirements	X	X	X	X	X
Discounting of AAUs issuance	X			X	
No transfer of AAUs at all			X		X

Source: own depiction based on sections 4.1 - 4.5

Conclusion: Countries which might be affected from a net-transfer of AAUs have implemented appropriate provisions. However, some countries/schemes do not issue AAUs at all. It can be observed that countries which have not achieved their GHG abatement targets either do not transfer AAUs at all (Switzerland) or discount the amount of AAUs they issue (New Zealand).

4.7.9 Provisions to avoid double counting

Avoiding the problem of double counting is one of the key elements of a DOP-scheme. To remind: Double counting implies the error of counting emission reductions from one GHG mitigation action twice. It evolves if GHG abatements lead to GHG reductions also in installations capped by an ETS¹⁴⁹.

To ensure that double counting of GHG abatements due to DOPs is avoided analyzed countries/schemes have set up certain provisions. A common way to avoid direct double counting¹⁵⁰ of emission reductions is to exclude domestic offset projects in facilities which are already covered by a corresponding emissions trading scheme. This restriction was made – as shown in the following table – in countries where an emission trading scheme is implemented¹⁵¹.

¹⁴⁹ See for a more detailed description chapter 4.1 or chapter 5.2.3

¹⁵⁰ See chapter 5.2.3 for an explanation of indirect and direct double counting

¹⁵¹ At the time of the New Zealand PRE no emission trading scheme was implemented in NZ.

To avoid indirect double counting of GHG-abatements, countries have prohibited DOPs outside of ETS installations which have also the potential to lower GHG-emissions of ETS installations. The most illustrative example is the ban of projects for saving electricity and thereby influencing the production levels of power plants regulated by the EU-ETS: Generating DOP-credits in the EU by saving electricity e.g. in households would also lead to a reduction of electricity output of power plants capped by the EU-ETS. As the output of power plants would decrease this would also lead to lower GHG emissions of power plants. As a result power plants could also generate revenues from selling their surplus allowances. Therefore, the sole action “electricity saving in households” would lead to revenues from DOP-credits and from selling surplus allowances of the power plants – thus this kind of DOP would lead to a double counting problem. For the same reason, DOPs generating (green) electricity are also excluded in considered EU-countries France and Germany. Producing green electricity would – in the European context – lead to a comparative lower need for producing fossil based electricity. This means, generating DOP-credits from green electricity production would also lead to a release of EU-allowances from fossil fired power plants¹⁵² – which would result in the calculation error of counting emission reductions twice.¹⁵³ The exclusion of electricity projects connected to the grid is also true for Switzerland, although the argumentation is slightly different: Firstly, Switzerland excludes all project-types which run contrary to their target of reducing electricity demand¹⁵⁴. Secondly, by definition electricity generation causes nearly no GHG-emissions in Switzerland¹⁵⁵. Thus, savings in electricity demand or increased production of “green electricity” does not lead to lower GHG-emissions of Swiss electricity generation. Also the RGGI scheme has – in principle – excluded DOPs which would effect GHG emissions of capped installations. However, to further promote a conversion of the energy system towards sustainability, RGGI has introduced an “Allowance Retirement for Voluntary Renewable Energy Purchases”.

By this “Allowance Retirement for Voluntary Renewable Energy Purchases”, green electricity could be promoted without causing double counting problems. This provision is based on installing a set-aside of allowances (held by the regulatory agency) otherwise issued to capped facilities. If green electricity projects are carried out, allowances are retired from this set-aside. However, it has to be added, that retiring of allowances causes a financial loss for the regulatory agency instead of auctioning these allowances to capped installations.

In a condensed manner Table 12 shows provisions of different countries to avoid the double counting problem. The provisions are widely similar, just New Zealand differs from other schemes in this aspect as no ETS was established there at the time of the New Zealand DOP-scheme.

¹⁵² Taking a raising demand for electricity into consideration, producing green electricity could also lead to a less need for fossil fired power plants to offset their emissions, or a less need to bring down GHG-emissions within these installations. In this case – assuming the possibility to generate offset-credits from green electricity DOPs – overall GHG emissions could even increase because of the lower incentive for generators of fossil fuel based electricity to invest in “cleaning” their own facilities.

¹⁵³ See also for further explanation RGGI [2] (2007), pp. 5 & 6

¹⁵⁴ Already this argumentation prohibits fuel changes from mineral oil to electricity.

¹⁵⁵ Schweizer Bundesamt für Umwelt (BAFU), Schweizer Bundesamt für Energie (BFE) (2008), p. 8

Table 12 Provisions to avoid double counting

	France	Germany	Switzerland	New Zealand	RGGI
Exclude offset projects in facilities capped in the ETS (that emission reductions do not count twice)	X	X	X		X
Exclusion of offset projects which already decrease GHG emissions in ETS-capped facilities	X	X	X		X
Set-aside/Retirement of credits when implementing double counting causing DOPs					X

Source: own depiction based on sections 4.1 - 4.5

Conclusion: All considered countries/schemes have included provisions to exclude direct as well as indirect double counting of GHG emission reductions if emission trading schemes are implemented.

4.7.10 Incompatibilities of DOPs with governmental subsidies

The question whether DOPs have also access to governmental funding schemes is a very crucial one – mainly for the profitability of DOPs and thus for their attractiveness.

Some countries as Switzerland or New Zealand have not excluded DOPs from having access to governmental funding schemes as long as additionality requirements are not harmed. Also Germany for instance does not prohibit this access in principle. However, the DEHST¹⁵⁶ explicitly states that it is practically not possible to display GHG-reductions caused by public funding and those caused by financial incentives of DOPs: “The German Project Mechanism Law (also) provides that financial incentives that are already granted for the project have to be deducted from the baseline. Practically this is not really feasible, therefore project developers have to decide whether to use these incentives [governmental subsidy incentives, remark] or JI, not a combination of both.”¹⁵⁷ Therefore Germany – in practice – excludes DOPs from having access to governmental funding schemes. On the contrary to that, Switzerland does not set the baseline for DOPs by subtracting the GHG-reduction effect of public subsidies. It rather splits the amount of generated offset credits and proportionally allocates them to the various sources financing DOPs.¹⁵⁸ This means, if the government grants a certain proportion of needed funds necessary to carry out DOPs, then the government also achieves the same proportion of generated offset credits. The rest goes e.g. to the project implementer. In contrast to that RGGI has explicitly excluded access of DOPs to public funding schemes: “CO₂ offset allowances shall not be awarded to an offset project that receives funding or other incentives from any System Benefit Fund”¹⁵⁹

¹⁵⁶ “Deutsche Emissionshandelsstelle”, German Emission Trading Authority

¹⁵⁷ Smuda (2009)

¹⁵⁸ Schweizer Bundesamt für Umwelt (BAFU), Schweizer Bundesamt für Energie (BFE) (2008), p. 16

¹⁵⁹ RGGI [3] (2008), p. 93

Table 13 provides an overview about (in)compatibilities of DOPs with governmental subsidies.

Table 13 Incompatibilities of DOPs with governmental subsidies

	France	Germany	Switzerland	New Zealand	RGGI
Incompatible (in practice)	X	X			X
Compatible in principle if still additional			X	X	

Source: own depiction based on sections 4.1 - 4.5

Conclusion: Access for DOPs to national funding schemes need not necessarily be prohibited. However, it might – but not necessarily – cause problems in setting the baseline for DOPs and therefore in calculating GHG-reductions solely achieved by the financial incentive from DOPs.

4.7.11 Provisions to keep transaction and administration costs low

Provisions to keep transaction and administration costs (“side costs”) for Domestic Offset Projects as low as possible are essential for the economic attractiveness of DOPs and thus for the potential of DOPs. Therefore, countries have developed certain provisions to keep these costs at a low level, as summarized in Table 14.

One option to keep side costs low is to provide a list of project-types which are considered as eligible for DOPs. This provision is also known as *‘the standard-based approach’*. Predefining eligible project-types, firstly, reduces the risk for investors/project developers that project proposals get refused after costs for project designing have already occurred. Secondly, public authorities could also provide methodologies for MRV of projects, which reduces costs for investors to develop own MRV-methodologies. The disadvantage of this approach is the limited flexibility. If only those projects are allowed which fit in the frame of pre-defined methodologies potentially excludes innovative projects outside of this frame.

To achieve higher flexibility, some countries/regions use a *‘project-by-project approach’*. This approach may impose higher side costs for developing methodologies for MRV and eligibility checks. However, countries often use a mixture of the two approaches, offering a list of project-types for which methodologies are prepared already while keeping the door open for new project ideas.

A further provision for keeping side costs as low as possible is the possibility/obligation to *pool* projects until they have reached a certain project size. A special case of pooling of projects is a *programmatic approach* as applied in Germany.¹⁶⁰ The specialty of this approach is that project participants can start their participation at any time within the project duration. Also MRV is done only on a sample to limit administration and transaction costs.

¹⁶⁰ See also chapter 4.2

Another possible alternative to minimize transaction costs for project developers might be co-funding from governments, such as subsidizing or completely bearing the relatively high transaction costs of small-scale projects. However, although investors might be helped with these provisions, these costs have to be covered by the public.

Table 14 Provisions to lower administration and transaction costs

	France	Germany	Switzerland	New Zealand	RGGI
Standard-based approach	X		X		X
Project-by-project-based approach				X	X
Programmatic approach		X			
Obligation of pooling small-scale projects	X			X	X
Possibility of pooling small-scale projects		X	X		
Financial assistance to minimize transaction costs		X		possible	

Source: own depiction based on sections 4.1 - 4.5

Conclusion: There exist approaches for keeping relative transaction and administration costs low. All considered schemes try to bundle small-scale projects, either on a voluntary or obligatory basis are via a programmatic approach (Germany).

5 Chances, problems and possible solutions

DOP-schemes are economic incentive-based instruments to stimulate GHG abatements domestically. The major aims are to both support domestic GHG abatements as well as the achievement of government's climate protection targets.

As has been shown in the analysis of foreign DOP-schemes before, there are also other advantages¹⁶¹ leading to be in favor for this instrument. On the other side, the analysis has clearly shown possible disadvantages, where analyzed countries have set up provisions against it. Provisions to avoid disadvantages of DOPs have been already mentioned and discussed in the respective sections of chapter 4. However, the repetition of these provisions at this stage in a condensed manner is made for the sake of providing a tense compendium of those provisions.

In this chapter therefore, the chances of DOPs as well as their problems paired with possible solutions will be highlighted.

5.1 CHANCES ASSOCIATED WITH DOP-SCHEMES

Next to its nature to stimulate GHG abatements which would not be done otherwise, the instrument "Domestic Offset Projects" provides a number of other advantages. These are using the "search engine market" for finding GHG abatement opportunities, accelerated diffusion of "green" technologies, and co-effects of GHG abatements appearing domestically.

5.1.1 Using the "search engine market"

A main advantage of DOPs is to use decentralized knowledge from market participants about various GHG mitigation opportunities. It can be assumed that public authorities could never gather such comprehensive and detailed knowledge about GHG mitigation opportunities comparable with the knowledge of market agents. This leads to the suggestion that using this decentralized knowledge might lead to GHG abatements not accomplished otherwise.

5.1.2 Accelerated diffusion of technologies

Another advantage of Domestic Offset Projects is an accelerated diffusion of "sustainable/green" technologies at home. If DOPs stimulate measures where new technologies are implemented, two effects arise: Firstly, producing more units of certain technologies (e.g. solar panels) caused by a higher demand will result in production economies of scale. This means, producing one further unit of a certain technology reduces costs per unit. This might

¹⁶¹ E.g. using the "search engine market" for finding new GHG-abatement opportunities; or increasingly using private capital for accelerating the conversion of the energy system.

be due to the possibility that production processes for producing a certain technology can be organized as more industrialized. The second effect is the learning effect: This has – on the one side – repercussions on the costs of producing certain technologies. On the other side, also technical improvements of the sustainable/ green technologies might be accelerated. This could mean, that e.g. solar panels do not only become cheaper, but also become more productive in the sense that one panel produces an extended amount of heat or electricity.

5.1.3 Appearance of co-effects from GHG abatements domestically

The alternative of generating carbon offset credits domestically would be to purchase them from abroad. However, purchasing them from abroad rather than generating them domestically would imply that so-called “co-effects” from GHG abatement measures would not appear domestically.¹⁶² These co-effects are “side effects of climate change mitigation measures, which are not intended by these measures but are in many cases appreciated.”¹⁶³

Carrying out GHG abatements domestically leads in many cases¹⁶⁴ to improved health and ecologic effects due to less exposure of harmful substances beside the decrease in GHG emissions.¹⁶⁵ Less straightforward are statements about changes in GDP, employment or balance of trade. Some studies have stated positive effects of domestic GHG abatement measures on these economic performance indices: For instance, *Schleicher and Kratena (2001)* have stated positive impacts mainly due to a shifting from the import intensive demand on energy to labor intensive demand on assets (new technologies in the energy supply sector). Also *Kletzan, Steininger, Hochwald (2005)* showed positive economic effects of increased GHG abatement measures due to the Austrian subsidy scheme “Umweltförderung im Inland”. However, economic effects of GHG abatements might depend on the kind of abatement measure: *Kratena and Puwein (2002)* showed in their examination of a road charge for trucks that this GHG mitigation measure would result in a worsening of the trade balance due to an increased price level. However, they stated that GDP and employment would improve.

Another co-benefit of carrying out GHG abatement measures domestically is to be less vulnerable against shortages in fossil fuel supply. Buying carbon offset credits from abroad – that means less GHG abatements carried out domestically – would not contribute to make the economy more robust against supply shortages in fossil fuels mainly imported from abroad.¹⁶⁶

¹⁶² See Steiner (2006) for a comprehensive description of co-effects from GHG abatement measures

¹⁶³ Steiner (2006), p. 1

¹⁶⁴ One exception of positive co-effects from GHG abatements on human health could be the combustion of solid biomass compared to the fossil natural gas.

¹⁶⁵ See for instance the „Regional Air Pollution Information and Simulation” (RAINS) model, which “combines information on economic and energy development, emission control potentials and costs, atmospheric dispersion characteristics and environmental sensitivities towards air pollution”; Amann et al. (2004), p. 9

¹⁶⁶ Compare Steiner (2006), pp. 18 et seq.

5.2 PROBLEMS ASSOCIATED WITH DOP-SCHEMES AND POTENTIAL SOLUTIONS

The analysis of international DOP-schemes has shown some pitfalls of DOP-schemes. Some of them are especially relevant for Austria.

The most compelling problems are a possible widening of a country's emissions gap, competition for cheap abatement opportunities between the government and project developers, double counting of GHG abatements as well as possibly limited abatement potential and high transaction costs.

5.2.1 Widening of the emissions gap

One of the primary objectives of a DOP-scheme is that it supports the aims of the Austrian climate policy. This means that a DOP-scheme should assist in achieving the government's climate protection targets. This applies if a potential gap between real GHG emissions and a country's budget of AAUs diminishes after DOPs are carried out. However, this could be torpedoed if DOPs are not additional: International DOP-schemes have shown that project developers may get issued AAUs – or ERUs backed-up by AAUs – for reducing real GHGs. However, project developers may have an incentive to state that their DOPs achieved certain GHG abatements although these abatements would occur also in the absence of DOPs¹⁶⁷. This would therefore impede a country's efforts to close a potential emissions gap.

To eliminate non-additional DOPs, one supreme requirement of DOPs is – without exemptions – that strict additionality of DOPs has to be proven. This can be done by applying commonly used additionality tests. These tests do not check financial additionality only, but also identify barriers of GHG abatements for which more funds are necessary to overcome them.

However, it is clear that even strict additionality tests may not guarantee additionality completely – there might be certain projects which cannot be filtered out even by strict additionality tests. Therefore, the government might protect itself against this risk by applying certain provisions. For instance, international DOP-schemes¹⁶⁸ include provisions where the amount of AAUs claimed by the developers of DOPs is discounted. This could ensure – even if some projects were non-additional but still passed strict additionality tests – that the government would – over the entire portfolio of projects – not issue more AAUs than justified by real GHG-reductions. Another option to protect against non-additionality of certain projects is to siphon off a certain fraction of project developers' profits. This "risk premium" against non-additional projects could be used by the government to reinvest these funds into GHG mitigation measures whose GHG abatements were not converted into tradable carbon offset credits.

¹⁶⁷ For instance due to other legal provisions

¹⁶⁸ E.g. France, New Zealand

5.2.2 Competition for cheap abatement possibilities

The government has to ensure that the Austrian non-EU-ETS sectors perform well enough to achieve the overall Austrian climate protection target. To achieve this target, the government has to provide adequate incentives to stimulate a sufficiently high extent of GHG abatements in these sectors – for instance via subsidy incentives. Assuming a limited budget available to achieve short- and medium-term climate protection targets, the government has to activate especially low-cost GHG abatement potential.¹⁶⁹

Developers of Domestic Offset Projects also intend to exploit the most profitable GHG abatement potential of these sectors. This might lead to a “run” for the most profitable GHG abatement measures of the non-ETS sectors: the government is willing to exhaust them in order to achieve its climate protection targets at the lowest costs, and developers of DOPs would like to exhaust them because they potentially provide the highest profits from the entire portfolio of GHG-abatement measures.

In order to avoid that the government “looses” low-cost abatement opportunities to developers of DOPs, the government might restrict DOPs to certain sectors or project-types where past governmental incentives did not lead to satisfactory results. This means, the government could allow DOPs in sectors where seemingly only the “search engine market” can raise GHG abatement potential.

However, the government might also be willing to restrict areas for DOPs as little as possible. In order to be compensated for a loss of low-cost abatement potential the government could demand parts of the profits from DOPs. These parts of profits could then be used to achieve the governmental climate protection targets by exploiting the more costly GHG-abatement potential, while there would be no need for more public money.

5.2.3 Double counting

Double counting is an error in calculating real GHG reductions of DOPs. It addresses the problem of counting merits of one GHG abatement activity twice. There exist two kinds of double counting: direct and indirect double counting – both of them have to be avoided when carrying out DOPs.

Direct double counting: Emissions from facilities covered by an emissions trading scheme are already capped. Carrying out DOPs within these facilities would result in generating DOP-credits, while also allowances usable in the ETS were released. Therefore one GHG mitigation measure would result in generating/releasing of credits double as much as justified. Therefore, “project activities which result in direct emission reductions in installations participating in the EU-ETS have to be excluded from the generation of national emission reduction credits.”¹⁷⁰ This means in the case of Europe “that whenever EU allowances are

¹⁶⁹ This is true from the sole perspective of achieving short- and medium-term climate protection targets. From the overall economic perspective and from the perspective of achieving long-term climate protection targets it is advisable to also include co-effects of GHG abatement measures into consideration. Compare Pretenthaler, Steiner, Schlamadinger (2006)

¹⁷⁰ Betz, Rogge, Schoen (2006), p. 573

granted to an activity, installation or a sector, no national certificates can be generated from DOPs for their CO₂ emission reductions.”¹⁷¹

Indirect double counting: Also GHG abatements accomplished outside an ETS could cause double counting problems. A reduction of GHG emissions in non-ETS-sectors might cause emission decreases in facilities subject to the ETS. This can be easily shown at one example referred to Europe: “More efficient use of electricity and the associated electricity savings may free up EU allowances of electricity generators. If DOP-credits were issued for these activities, this would result in the reductions being double counted.”¹⁷²

To conclude: All projects which cause direct double counting have to be prohibited for DOPs. Also indirect double counting has to be avoided e.g. by subtracting GHG-reductions in ETS installations caused by DOPs.

One additional option to deal with this problem is to establish a set-aside for AAUs: “A special rule could be designed so that DOPs which will reduce indirect emissions receive allowances from a special reserve which will be set aside in the National Allocation Plan (NAP) for this purpose. The government would have to estimate the level of indirect emission reductions from DOPs over the allocation period and set this amount aside in a reserve. This reserve has to be deducted ex ante from the emission budget of all power plants within the EU-ETS, as they are the ones that would benefit from such double counting.”¹⁷³ However, issuing some credits to DOPs which face double counting problems instead of auctioning them to EU-ETS installations would cause a financial loss for the government.

5.2.4 Limited abatement potential and high transaction costs

Critics of DOPs often mention that the abatement potential of DOPs might be rather low – to low for implementing a new system. In fact, the potential of GHG abatements achievable by DOPs cannot be quantified ex-ante. Indeed, it has to be considered that the potential of DOPs depends also on the design of the DOP-system. This includes questions like the compatibility with governmental subsidies as well as restrictions of DOPs to certain sectors.

Highly connected with the GHG-abatement potential are transaction and administrative costs of DOPs. Especially small-scale projects face high transaction and administrative costs compared to their project size. A commonly used solution for that is pooling of many small-scale projects, or using a programmatic approach as applied in Germany.

¹⁷¹ Betz, Rogge, Schoen (2006), p. 573

¹⁷² Betz, Rogge, Schoen (2006), p. 573

¹⁷³ Betz, Rogge, Schoen (2006), p. 573 ; Betz, Rogge, Schoen (2006) have used the acronym DP (Domestic Projects) instead of DOP (Domestic Offset Projects)

6 Austrian circumstances and resulting lessons learned

In this chapter the existing emissions structure of Austria is displayed to show sectors in Austria potentially suitable for DOPs. Displaying the GHG-emissions structure should also ensure that the Austrian case will be compared with DOP-schemes facing similar surrounding conditions. Based on this and based on experiences drawn from other DOP-schemes, crucial characteristics for a potential DOP-scheme in Austria are defined.

6.1 AUSTRIA – ITS GREENHOUSE GAS EMISSIONS AND TRENDS

According to the depiction of the UNFCCC Austria's GHG emissions from processes and fuel combustion are comprised as they are shown in Figure 12. It is shown that the magnitude of GHG emissions from fuel combustion of "manufacturing industries and construction" combined with process caused GHG emissions of "industrial processes" is similar to the magnitude of GHG emissions from the transport sector. Also GHG emissions from "energy industries" and "other sectors"¹⁷⁴ are by a similar magnitude.

Figure 12 Breakdown of emissions by sector and in the energy sector (2007, w/o LULUCF)

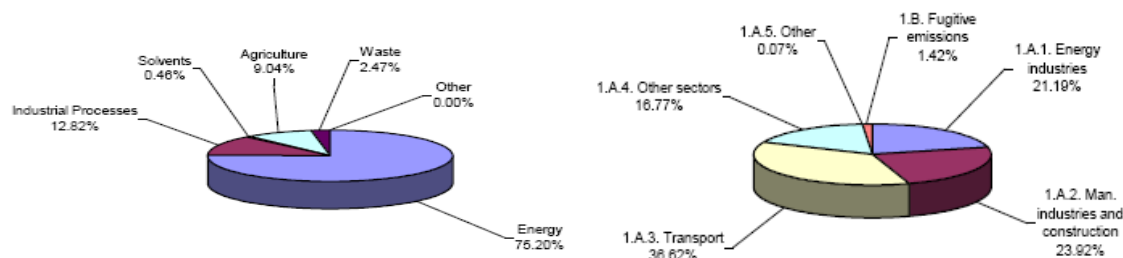

Source: UNFCCC¹⁷⁵

The trend of Austria's GHG emissions shows a slight increase at the beginning of the period 1990-2007. Since 2005 a slight decrease in GHG emissions can be observed.¹⁷⁶ (see Figure 13)

¹⁷⁴ Commercial/institutional, residential, agriculture/forestry/fisheries GHG emissions

¹⁷⁵ http://unfccc.int/files/ghg_emissions_data/application/pdf/aut_ghg_profile.pdf; November 24, 2009

¹⁷⁶ Schneider, Kuschel et al.(2010); pp.7, 33

Figure 13 Trend of Austria's GHG emissions from 1990-2007 (w/o LULUCF)

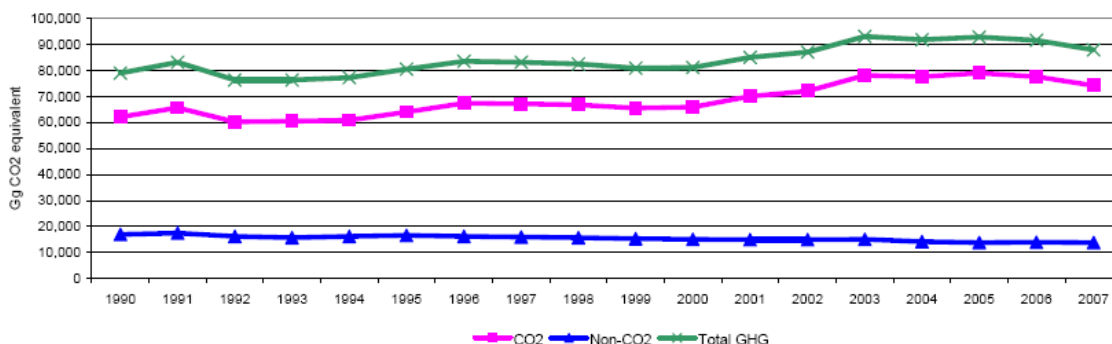

Source: UNFCCC¹⁷⁷

Going a bit more into detail: Figure 14 shows that namable reductions of GHG emissions could be achieved in the past in the waste sector and from reduced usage of solvents. However, GHG emissions from energy-related GHG emissions have increased considerably in the period between 1990 and 2007. Emissions increased especially from transport, fugitive emissions, manufacturing industries and construction and others¹⁷⁸. A sharp decrease could be observed in the category “other sectors”, which includes GHG emissions from commercial/institutional/residential emitters as well as GHG emissions from fuel combustion of agriculture/forestry/fishery emitters.

Figure 14 Change in greenhouse gas emissions/ removals (1990-2007) in %

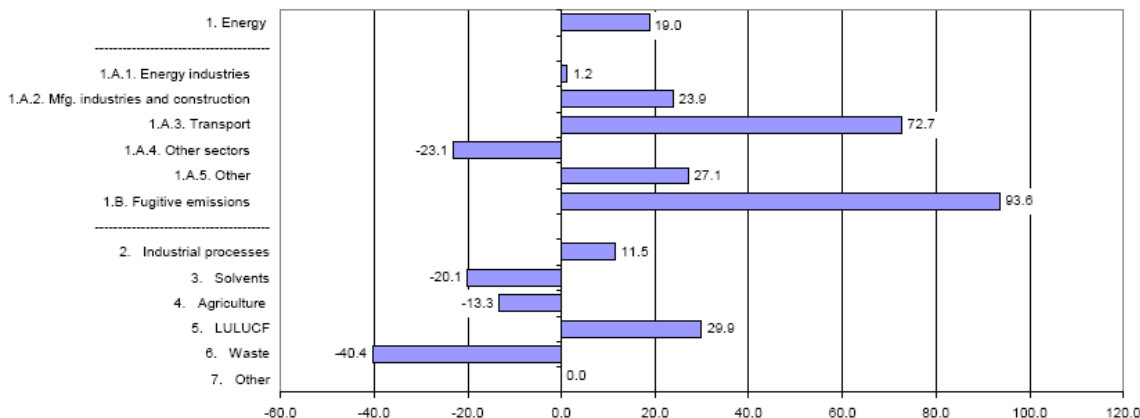

Source: UNFCCC¹⁷⁹

From Figure 14 it can be observed that certainly some reductions of GHG emissions could be achieved in the past. On the contrary, some sectors have faced a sharp increase in GHG emissions. However, the Austrian Climate Strategy¹⁸⁰ has assigned GHG emission targets to

¹⁷⁷ http://unfccc.int/files/ghg_emissions_data/application/pdf/aut_ghg_profile.pdf; November 24, 2009

¹⁷⁸ See for further explanation the specification of emitting sources in ANNEX III: Specification of emitting sources

¹⁷⁹ http://unfccc.int/files/ghg_emissions_data/application/pdf/aut_ghg_profile.pdf; December 19, 2008

¹⁸⁰ BMLFUW (2007), p. 101

each sector: only comparing these targets with real GHG emissions of particular sectors can answer the question whether GHG-abatement incentives introduced so far would be sufficient according to the climate strategy.

Transport

Compared to 1990, transport's GHG emissions have risen by about 73 percent by 2007 – from 14.1 mio. tons to 24.3 mio. tons.¹⁸¹ According to the Austrian Environmental Agency¹⁸² also an increased export of fossil fuels (7.2 mio. tons) due to price discrepancies between Austrian petrol stations and those of its neighboring countries have been responsible for this rise. Because of the sharp rise in GHG emissions the transport sector's GHG emissions were in 2007 5.4 mio. tons above the sector's target of 18.9 mio. tons¹⁸³.

Manufacturing industries and construction/ industrial processes

This sector faced a rise in GHG emissions of more than 20 percent in total from 1990-2007 – both from GHG emissions of fuel combustion and processes. Most of this rise has been caused by plants for iron and steel procession. Rises in GHG emissions are highly influenced by increases of outputs. 77 % of GHG emissions from manufacturing industries and construction/ industrial processes are already covered by the EU-ETS, the rest could potentially be covered by a DOP-scheme. GHG emissions of this part not covered by the EU-ETS amounts to 5.9 mio. tons in 2007. This amount would have to be reduced by 33 % to 3.7 mio. tons in order to achieve the governmental aimed GHG-reduction target of non-EU-ETS industries.¹⁸⁴

Commercial/Institutional/Residential emissions and fuel combustion emissions from Agriculture/Forestry/Fisheries (1.A.4. Other sectors)

GHG emissions of this category have steadily decreased. In 2007 GHG emissions of this category have been slightly below the targeted level in the climate strategy. However, the Austrian Environmental Agency states that this was also – among other factors – the result of mild winters of the years 2006 and 2007. Therefore it is not ensured that GHG emissions are that low in subsequent years.¹⁸⁵

Energy industries

This sector's GHG emissions have been just slightly over its 1990 level. However, a big difference arises when considering facilities covered by the EU-ETS and those which are not covered: The bulk of energy industries is covered by the EU-ETS (85 % of the sectors GHG emissions). This fraction achieved a reduction in GHG emissions by 17 % between 2005 and 2007. The other fraction – representing 15 % of this sector's GHG emissions – is not capped by the EU-ETS. This fraction faced a sharp increase of GHG emissions by 13 % in the same

¹⁸¹ Schneider, Wappel et al. (2009), p. 38

¹⁸² Schneider, Wappel et al. (2009), p. 38

¹⁸³ Rechnungshof (2008); p.18

¹⁸⁴ Schneider, Wappel et al. (2009), p. 40

period of consideration. In 2007 the fraction of energy industries not covered by the EU-ETS has emitted 2.0 mio. tons – 15 % more than aimed at the Austrian Climate Strategy.¹⁸⁶ Main factors for the sharp rise in GHG emissions between 2005 and 2007 in the fraction of interest have been waste incineration, the sector's use of energy and increased N₂O and CH₄ emissions.

Agriculture

In the period between 1990 and 2007 agricultural GHG emissions has dropped by more than 13 % because of a decreasing number of cattle and decreasing usage of mineral fertilizer. This sector's GHG emissions have just been slightly (0.8 mio. tons) above the aimed level of 7.1 million tons¹⁸⁷. However, the decreasing trend of the past could not be observed any more in the period 2005-2007: the number of cattle has stabilized, also more mineral fertilizers are used once again.

Waste

In the considered period, GHG emissions caused by waste have sharply decreased by more than 40 % due to a reduced quantity of waste, decreasing carbon content of waste and the increased flaring of landfill gas. The "waste" sector has nearly achieved the national target for GHG reduction (2.1¹⁸⁸ mio. tons) – mainly due to the prohibition to landfill untreated waste.¹⁸⁹

F-gases have decreased by 9.5 % between 1990 and 2007¹⁹⁰, mainly due to the decree for industrial gases (Industriegasverordnung 2002).¹⁹¹

Conclusion

In this detailed analysis of GHG emission trends and target achievements it turned out that the sectors *transport* as well as the fractions not covered by the EU-ETS from *energy industries* and *manufacturing industries and construction/ industrial processes* face considerable gaps to achieve their sectors' targets. Furthermore, target achievement of *Commercial/Institutional/Residential* emissions combined by fuel combustion emissions from *Agriculture/Forestry/Fisheries (1.A.4. Other sectors)* are questionable as future increases in GHG emissions are expected. Also, agriculture and waste sectors face a slightly higher level than aimed at the Austrian Climate Strategy: although the waste sector might achieve its target, the agricultural sector might remove from its current level if the trend of the near past continues also in the future.

It turns out that the last years' decrease in GHG emissions could be reversed or at least the decreasing trend could ebb away if helpful factors do not occur (e.g. mild winters). Even if the economic crisis of 2007 and beyond certainly leads to a further decrease in GHG emissions,

¹⁸⁵ Compare Schneider, Wappel et al. (2009), p. 36

¹⁸⁶ Schneider, Wappel et al. (2009), p. 38

¹⁸⁷ BMLFUW (2007), p. 101

¹⁸⁸ Rechnungshof (2008); p. 18

¹⁸⁹ Schneider, Wappel et al. (2009), p. 38

¹⁹⁰ Anderl et al. (2009), p. 159; and Schneider, Wappel et al. (2009), p. 40

¹⁹¹ Schneider, Wappel et al. (2009), p. 40

further actions are necessary to ensure a sufficient and permanent reduction of the domestic GHG emissions level.

6.2 LESSONS LEARNED FOR AUSTRIA

In this section basic principles and “corner stones” of a potential Austrian DOP-scheme should be defined. This is based on experiences from other DOP-schemes, from their advantages and potential pitfalls. Also, the current situation of GHG emissions in Austria will be included.

Included sectors

The analysis of Austria’s GHG-emissions and its trends has shown that nearly all non-ETS sectors and -facilities did not achieve their GHG-emission targets or are not likely to keep their current GHG-emissions constant respectively. Therefore – in principal – all non-ETS sectors require additional incentives for further GHG-abatements.

Certification method

The analysis of international DOP-schemes has shown that certification methods can both be based on Joint Implementation as well as on nationally defined standards. Both methods are possible in Austria, however, only Joint Implementation based certification methods allow offset credits to be used in the EU-ETS. Credits generated via other standards might only be sellable for voluntary offsetting purposes; the market for those will be smaller.

No net-transfer of AAUs

Austria currently faces a Kyoto-gap, i.e. the amount of real GHG-emissions is higher than the amount of AAUs held by the Austrian government. Taking current GHG-emission trends as guidance it could be carefully assumed that Austria might not over fulfill its expected GHG-emissions target for 2020. This leads to the conclusion that a potential Austrian DOP-scheme must not result in a net-transfer of AAUs, i.e. transferring AAUs without reducing real GHG-emissions by an extent at least as high as the amount of transferred AAUs. For that it has to be ensured that DOPs are strictly additional.

Assisting governmental climate protection efforts

A potential Austrian DOP-scheme should not impede efforts of the government to achieve Austria’s internationally agreed climate protection targets. This means, DOPs should not constrain the portfolio of especially cheap and easily achievable GHG abatements assignable to the government’s efforts to achieve its GHG emission target. However, if so the government must be compensated for that appropriately.

Avoiding double counting

A crucial element of a potential Austrian DOP-scheme is to avoid the calculation error of counting emission reductions twice. Therefore, DOPs must not be eligible in facilities capped by the EU-ETS. The same is true for DOPs which cause GHG-emission reduction in EU-ETS installations by the same extent as reduced by DOPs themselves. Therefore grid-connected electricity-saving projects have to be excluded. Solving the problem of double counting via installing a set-aside of offset-credits could only be done for periods where no NAPs (National Allocation Plans) are published yet.

Incompatibilities of DOPs with governmental funding

Domestic Offset Projects need not be excluded from having access to governmental funding. However, attention has to be laid on setting the baseline.¹⁹²

Low transaction and administration costs

In order to increase the potential for GHG abatements of DOPs administration and transaction costs have to be as low as possible. In principle standard-based, project-by-project as well as pooling and programmatic approaches would be possible.

¹⁹² See example from Switzerland and constraining requirements from Germany

7 Domestic Offset Projects – Classification and mode of operation

International examples show that DOP-schemes can be designed in various ways. They are either designed to generate carbon offset credits eligible for compliance with global (or supranational) climate protection regimes, e.g., with Kyoto- or, possibly, with post-Kyoto targets. On the other hand, DOP-schemes can be set up also on purely national rules where credits are generated for domestic use only. Also, they could be designed to generate credits eligible for the voluntary carbon offset market, i.e., for voluntary offsetting carbon emissions.

Suitable for Austria would be two categories: Either DOPs generating credits suitable for compliance (EU-ETS, Kyoto, post-Kyoto) or DOPs accepted for voluntarily offsetting carbon emissions.

In the following subsections, the framework of these two categories of DOP-schemes based on the rules for either international or voluntary compliance will be outlined. Thereafter the climate protection instrument “Domestic Offset Projects” will be compared with other climate protection mechanisms according to various evaluation criteria.

7.1 DOP-SCHEME BASED ON THE VOLUNTARY CARBON OFFSET MARKET

This category of DOP-schemes is based on generating carbon offset credits usable for the voluntary carbon offset market.

The required actors within this category of DOP-schemes are project developers and buyers of carbon offset credits. An intermediary may be necessary for administrative reasons only. A role of the government is not necessarily required, but possible¹⁹³.

¹⁹³ See chapter 9.1

Figure 15 Schematic illustration of the category of DOP-schemes generating voluntary carbon offset credits

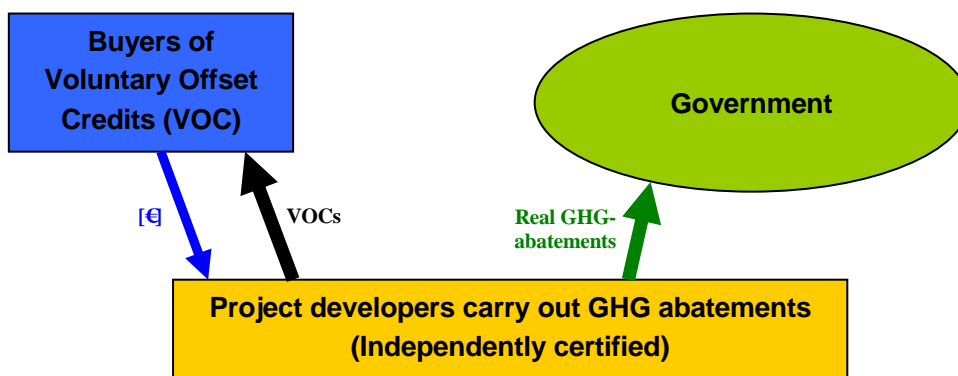

Source: own illustration

The possible procedure of this category of DOP-schemes can be explained along the lines of Figure 15: Private investors/ project developers implement GHG-mitigation projects domestically. Achieved GHG-emission reductions can be (independently) certified according to chosen standards for voluntary carbon offsets¹⁹⁴. Private or commercial individuals purchase those credits e.g. for marketing reasons. Revenues from sold credits can then be used to cover costs of accomplished GHG abatement projects. The government does not need to take any actions.

Generated voluntary offset credits (VOC) can be neither used for compliance to a global climate protection regime, nor within supranational emission trading regimes like the EU-ETS. They can serve only for offsetting carbon emissions in the voluntary market. This means that generated carbon offset credits are only eligible outside the “official”, international carbon market. Hence, dealing with this kind of credits does not affect the budget of AAUs neither of host countries nor of purchasing countries. In other words, while real GHG-emissions are reduced through GHG-mitigation projects, thereby generated carbon offset credits do not affect a country’s budget of AAUs. The effects on the – currently existing – emissions-gap are illustrated in Figure 16:

¹⁹⁴ These rules vary according to applied standards. See also Kollmuss, Zink, Polycarp (2008)

Figure 16 Schematic illustration of changes of real GHG-emissions and of the Austrian AAU-budget before and after generating voluntary carbon offset credits in Austria

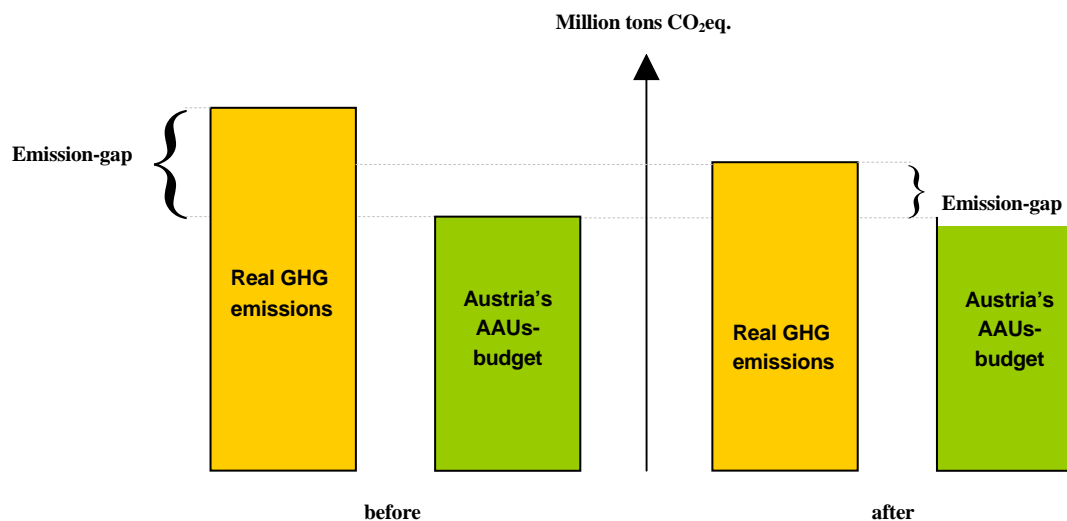

Source: own illustration

Figure 16 distinguishes between two states: before and after carrying out DOPs whereby credits are only usable for the voluntary carbon offset market. Prior to DOPs a certain gap between real GHG-emissions and the amount of held AAUs may exist.¹⁹⁵ Carrying out DOPs of this category, real GHG- emissions decline while the country's amount of AAUs stays the same.

Since 2007 such a voluntary carbon offset market already exists in Austria.¹⁹⁶ Credits for this market are also generated by taking GHG mitigation projects being in the pipeline of the "Austrian environmental support scheme"¹⁹⁷ Because of restricted funds assigned for this support scheme, there are many projects which fulfil requirements for funding, but cannot be supported. The voluntary carbon offset market helps to fund also these projects.

However, traded volumes within this market are fairly minor.¹⁹⁸ One reason for that could be the relatively high prices for offset credits.¹⁹⁹ Referring to information of the Austrian companies *Kommunalkredit Public Consulting* and *Allplan*²⁰⁰, however, prices of credits for offsetting carbon emissions often play a minor role as side costs²⁰¹ often exceed costs for carbon credits. Also purchasers of voluntary offset credits often demand credits from projects which could be used for marketing purposes, e.g. companies have enabled thermal restorations of schools with their purchase of carbon offset credits.

¹⁹⁵ Currently (2010) this is true for Austria

¹⁹⁶ See for instance www.climate-austria.at

¹⁹⁷ German translation: "Umweltfoerderung im Inland (UFI)"

¹⁹⁸ In 2009 10,592 tons of CO₂ referred to the entire physical life of investments where compensated; Kommunalkredit Public Consulting [4] (2009), p. 11

¹⁹⁹ See for that also www.climate-austria.at

²⁰⁰ Personal interviews, 2008

²⁰¹ Side costs are costs for providing information for potential purchasers as well as costs for estimating carbon emissions of activities which emissions should be balanced.

There are certainly purchasers of voluntary carbon credits who set attention on projects usable for marketing purposes rather than on the price for credits. However, currently the Austrian voluntary carbon offset market is only a niche market. To make voluntary offset credits attractive also for the mass of consumers, the price for the “commodity carbon offset credit” might have to be lowered substantially.

Conclusion: DOP-schemes based on the voluntary carbon offset market are advantageous for the current Austrian GHG-emissions gap. Therefore this market has already been established in Austria. However, its role to abate GHGs is currently fairly minor. One reason for that might be that the voluntary carbon offset market does not provide offset credits attractive enough for the mass of consumers.

7.2 DOP-SCHEME BASED ON JOINT IMPLEMENTATION

Within this category of DOP-schemes carbon offset credits eligible for compliance with international and global climate protection regimes are generated. According to current rules of the global climate protection regime, offset credits generated in industrialized countries and usable for international compliance have to fulfil the requirements of the offset generating mechanism “Joint Implementation”²⁰². Credits generated under this mechanism are called “Emission Reduction Units” (ERUs). The future of this mechanism is currently under discussion in climate protection summits²⁰³. However, it is assumed that such a mechanism will also exist in future climate protection regimes - maybe in a slightly, but not fundamentally, different design.

Potential purchasers of ERUs are on the one hand countries using credits to comply with their GHG-reduction targets. On the other hand, installations covered by national or supranational emission trading schemes use this credits to comply with their GHG emission caps.²⁰⁴ Prices for these credits are not determined in Austria but on the international market for ERUs. The period of time where ERUs can be generated is called “crediting period”. This crediting period is identical with the periods of global climate protection regimes – currently the “Kyoto-period” 2008-2012. Projects based on JI can only generate credits within the period when projects have been implemented. Thus, in order to generate as many credits as possible, it is necessary that projects become implemented at the beginning of a crediting period rather than at its end. Credits which have been used for compliance already become invalid for the next period.

The mechanism “Joint Implementation” stipulates that JI-projects – although carried out domestically – have to include foreign project developers. However, in many cases only domestic actors are interested in GHG-abatements of domestic facilities – probably due to the fact that they are the only actors who possess necessary information about cheap opportunities for GHG-abatements²⁰⁵. Therefore, following the examples of Germany and

²⁰² See chapter 3

²⁰³ E.g. in the Conference of Parties (COPs)

²⁰⁴ Carbon Offsets may only be used to a limited extent. Limits for offset usage are widely different among ETSs.

²⁰⁵ See also Smuda (2009)

France, an essential element of this category of DOP-schemes is that DOPs are accomplished by domestic actors although foreign project partners are included pro forma. In that case, this category could also be called “Domestic JI”.

Essential actors for DOP-schemes based on JI are developers of DOPs as well as purchasers of generated credits. For administrative reasons only also an intermediary might be helpful. In addition to that the government plays an important and essential role.

Figure 17 Schematic illustration of DOP-schemes based on Domestic JI

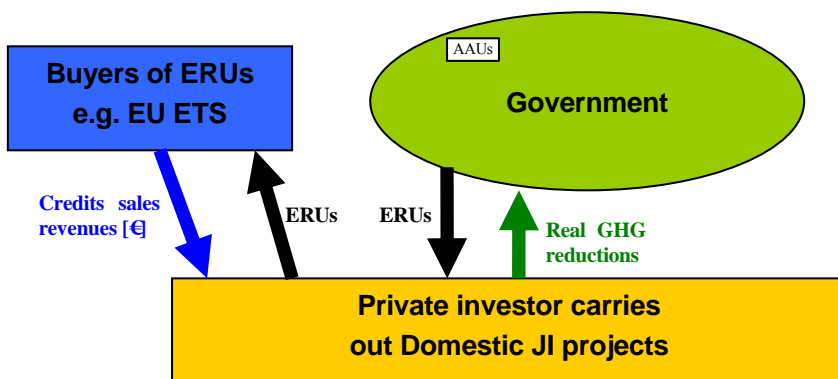

Source: own illustration

The possible procedure of this category of DOP-schemes can be explained using Figure 17: Private investors/ project developers implement GHG-mitigation projects domestically and certify them according to the rules of the Joint Implementation mechanism. After saved GHG emissions are verified the government issues credits – Emission Reduction Units (ERUs) in that case – by an appropriate extent. Issued ERUs would be eligible for international (Kyoto and post-Kyoto) compliance as well as for compliance with the EU-ETS for instance. As this category of DOP-schemes would be embedded within the framework of the “official” global climate protection regime, it would also have implications on the AAU-balance of the projects’ host country. In particular, if the government issues ERUs to project developers due to real GHG-reductions, the same amount of a project’s host country’s AAUs has to be used as back-up for these ERUs. This means that the government would have to transfer this amount of AAUs to project developers and therefore would not be able to use these AAUs for own compliance²⁰⁶. In sum, this mechanism theoretically implies a zero-sum game for the government: the budget of governmental-controlled AAUs declines, whereas DOPs also reduce real GHG-emissions by the same extent. Thus, for achieving the government’s internationally agreed climate protection targets, this kind of DOP-schemes neither improves nor worsens the country’s situation. This is illustrated in Figure 18:

²⁰⁶ The government has to prove its compliance to international climate protection targets by possessing the same amount of AAUs as real GHGs (CO₂-equivalents) had been emitted.

Figure 18 Schematic illustration of changes in real GHG emissions and in Austria's AAUs-budget before and after generating Emission Reduction Units (ERUs)

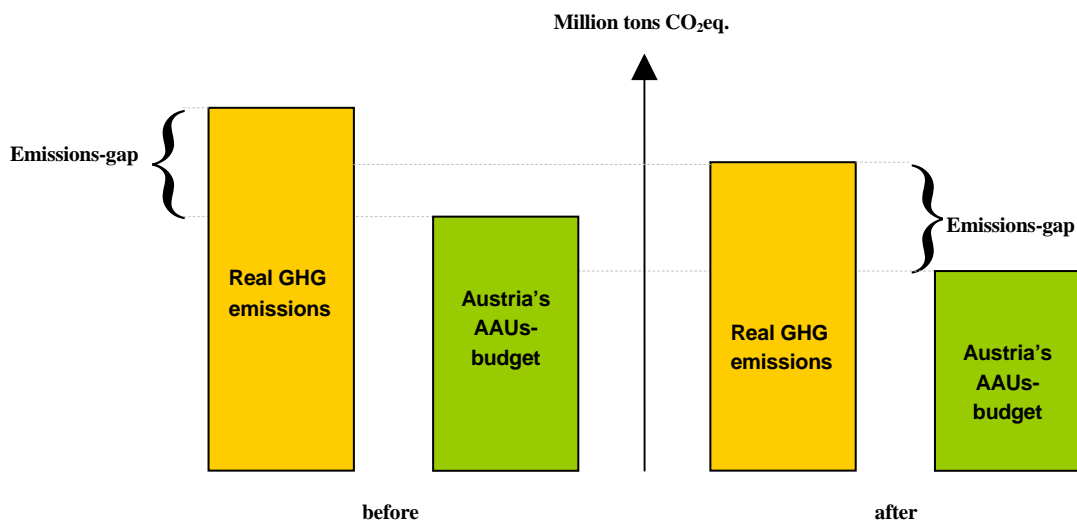

Source: own illustration

Figure 18 distinguishes between two stages: before and after carrying out DOPs whereby credits are usable for international compliance. Prior to DOPs a certain gap between real GHG-emissions and the amount of held AAUs may exist.²⁰⁷ Carrying out DOPs of this category, real GHG-emissions decline while also the host country's amount of AAUs declines by the same extent.

This first rough analysis shows that the government would – in theory – neither be better off nor worse off if DOPs based on Domestic JI were implemented. However, it has to be kept in mind that at Domestic JI the government bears certain risks²⁰⁸ without simultaneously taking advantage of such a scheme: Investors could pretend that their projects are additional even if they were not.²⁰⁹ In that case a certain emissions-gap would be even widened. Also, DOPs based on JI would compete with the government for achieving cheap GHG abatements.²¹⁰ In order to reduce these risks and to make sure that the government also benefits from this climate protection instrument, certain provisions and a stronger role of the government should be considered.

Conclusion: Credits generated by this category of DOPs face a wide and diversified market. In theory it keeps a certain emissions-gap constant, i.e. it neither makes the government worse off nor better off. However, the government faces certain risks (e.g. non-additionality of projects, competition for cheap abatement possibilities). Therefore certain provisions are necessary that the government becomes compensated for these risks and also benefits from DOPs.

²⁰⁷ Currently (2010) this is true for Austria

²⁰⁸ See chapter 5.2

²⁰⁹ See chapter 5.2.1

²¹⁰ See chapter 5.2.2

7.3 ANALYSIS OF THE INSTRUMENT “DOMESTIC OFFSET PROJECTS”

One of the most essential questions in this paper is whether the instrument “Domestic Offset Projects” provides a potential value-added in comparison to other, existing climate policy instruments.

For that reason, the instrument “DOPs” will be evaluated and compared with other instruments on the basis of certain criteria. These criteria include cost efficiency for achieving certain GHG abatements, need for public funds, flexibility, governmental need for information, extent of leading to competition for exploiting cheap abatement options and extent of support of this instrument to achieve governmental climate protection targets.

7.3.1 Cost efficiency

The main question of cost efficiency is whether a pollution control instrument could achieve certain GHG-abatements at least costs.

Perman et al. (2003) states important criteria²¹¹ for evaluating whether pollution control instruments lead to least cost solutions:

- “A least-cost control regime implies that the marginal cost of abatement is equalized over all firms undertaking pollution control;
- A least-cost solution will in general not involve equal abatement effort by all polluters;
- Where abatement costs differ, cost efficiency implies that relatively low-cost abaters will undertake most of the total abatement effort, but not all of it.”

Domestic Offset Projects intend to impact GHG-abatements of individuals on a voluntary basis by providing economic incentives. The same mode of operation can be observed when subsidies or taxes on energy use are implemented. Therefore, these instruments are also called economic incentive-based instruments. In the same breath awareness building measures should be mentioned, although this instrument is usually not classified as classic economic incentive-based instrument: By providing more comprehensive information in the context of GHG-abatements, it reduced costs for gathering information and therefore serves as a kind of “subsidy for gathering information” – information, which ultimately might be crucial for individuals to be willing for invest into GHG-abatement measures. This family of economic incentive-based instruments predominantly stimulates abatement potential which can be raised by lowest costs: “Incentive-based instruments work by creating incentives for individuals or firms to voluntarily change their behaviour. Employing incentives to make behaviour less polluting can be thought about in terms of prices and markets. Taxes,

²¹¹ Perman et al. (2003), p. 205

subsidies and transferable permits create markets for the pollution externality. In these markets, prices exist which generate opportunity costs that profit-maximizing firms will take account of in their behaviour²¹².

In contrast to economic incentive-based instruments, command and control (C&C) instruments²¹³ stimulate GHG-abatements by forcing individuals to change behavior or to invest into technologies they would not have invested otherwise. That means C&C instruments “operate by imposing mandatory obligations or restrictions on the behaviour of firms and individuals”²¹⁴. Figure 19 illustrates the costs for polluters at a certain amount of GHG-abatements achieved by C&C instruments.

Figure 19 Schematic illustration of abatements costs due to command and control instruments faced by polluters with different marginal cost curves for a certain abatement level X

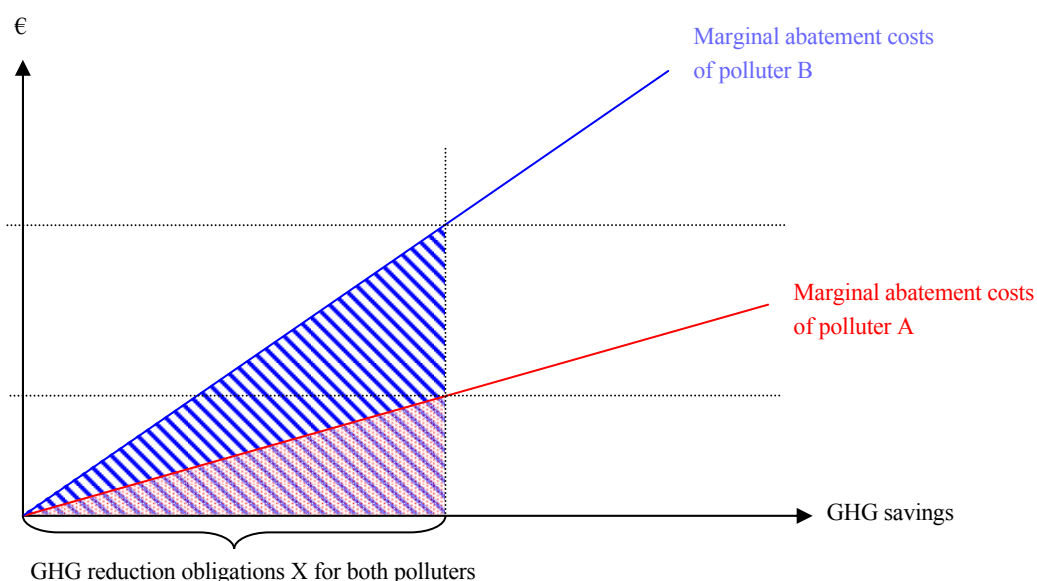

Source: own illustration based on Perman et al. (1999), p. 315

Figure 19 shows different marginal abatement cost curves for two polluters: A and B. These marginal abatement cost curves basically express different abatement opportunities faced by different polluters. Imposing a certain level X of required GHG-abatements equally to both polluters does not take into account their different marginal abatement costs. Thus, C&C instruments demanding a certain amount X of GHG-abatements from both polluters cause costs for polluter A displayed by the red dotted triangle and costs for polluter B displayed by the blue shaded triangle.

²¹² Ibid., p. 217

²¹³ “the controls may apply to the quantities of outputs produced (either the intended final output or the pollutant itself), to the quantities of inputs used, to the technology (e.g., minimum technology requirements) used in production processes, or to the location or timing of pollution activities”; Perman et al. (1999), p. 303

²¹⁴ Perman et al. (2003), p. 217

It can be observed from Figure 19 that GHG-abatements achieved by C&C instruments lead to the situation where marginal costs of abatements are not equalized over all polluters, the abatement effort is equal for all polluters, and the polluter with relatively low-cost abatement options does not undertake most of the abatement effort. Comparing these statements with the above-mentioned criteria for cost-effectiveness of abatement efforts suggested by Perman et al. (2003), the conclusion can be drawn that Command & Control instruments – if not taking into account potentially different marginal abatement costs of polluters – cannot achieve GHG reductions at least costs.²¹⁵

In contrary to that, Figure 20 shows the costs for achieving the same amounts of GHG-abatements stimulated by economic incentive-based instruments:

Figure 20 Schematic illustration of abatements costs due economic incentive-based instruments faced by polluters with different marginal cost curves and same abatement level 2*X

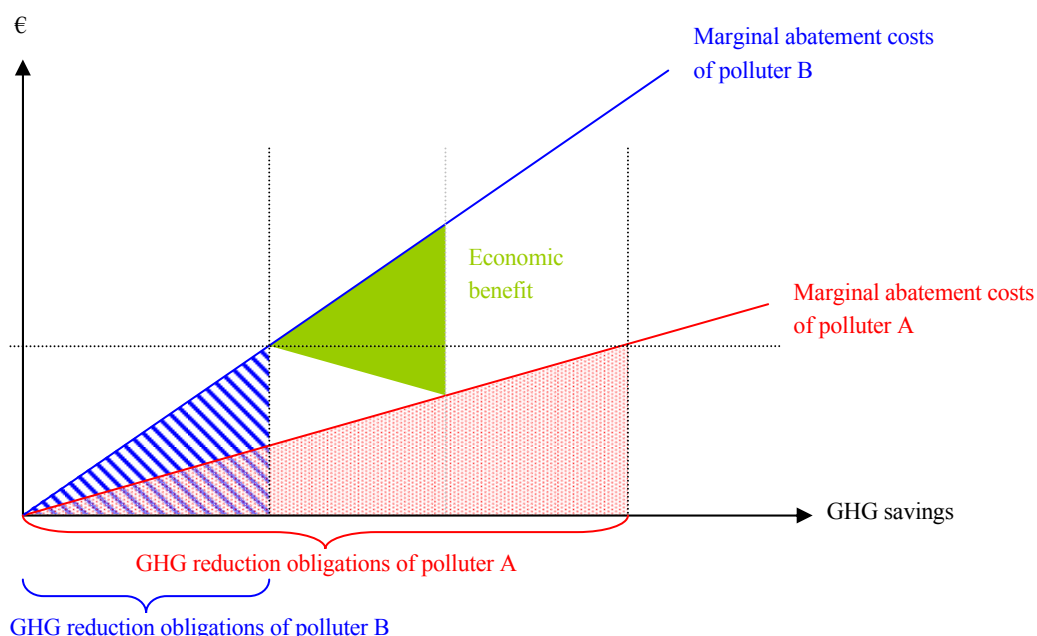

Source: own illustration based on Perman et al. (2003), p. 205

Figure 20 shows once again polluters A and B facing the same marginal abatement cost curves as illustrated in the example before. Once again, the same amounts of GHG-abatements (2* level X) should be achieved as in the example before – now with economic incentive-based instruments. Achieving these GHG-abatements with economic incentive-based instruments results that polluter A – the polluter with relatively low marginal costs for GHG-abatements – reduces a higher amount of GHGs than polluter B (polluter with relatively

²¹⁵ „The use of such regulations can be cost efficient, as it is possible in principle to choose emission standards for each polluter that result in the marginal costs of abatement being equal over all polluters. However, to do this, the control authority would need to know the abatement cost function for each firm. The control authority is very unlikely to have sufficient information to set standards for each polluter in this way” Perman et al. (1999), p. 303

high marginal costs for GHG-abatements). In sum, polluter A bears higher costs (red dotted triangle) than polluter B (blue shaded triangle).

The following experiences are made when achieving a certain amount of GHG-abatements due to economic incentive-based instruments: marginal costs of abatements are equalized over all polluters, the abatement effort is not equal for all polluters, and the polluter with relatively low-cost abatement options does undertake most of the abatement effort. Comparing these statements with the above mentioned criteria for cost-effectiveness of abatement efforts suggested by Perman et al. (2003), one can conclude that Domestic Offset Projects as well as other economic incentive-based instruments can achieve certain GHG reductions at least costs. This means, applying economic incentive-based instruments rather than C&C instruments leads to reductions of overall costs displayed by the green triangle in Figure 20. These savings can also be named as an economic rent for applying economic incentive-based instruments rather than C&C instruments.

The discussion above about efficiency gains at applying economic incentive-based instruments rather than C&C instruments for achieving a certain amount of GHG-abatements can be also analogously applied at the current design of the EU climate policy: this comprises “currently two separated markets”²¹⁶ for GHG-mitigation – Non-ETS and ETS – with diverse obligations of GHG-mitigation and diverse marginal abatement costs. Applying of DOPs would link these two markets. Thus, if marginal abatement costs in the EU-ETS market are higher than those in the Non-ETS-area, introducing DOPs promote an adjustment of marginal abatement costs in both markets. Whether this is the case “depends to a large degree on the allocation of allowances to the ETS-sectors compared to the stringency of measures planned outside the ETS”²¹⁷, which differs considerably by EU-member state. For the case of Austria Peterson (2006) states that from the point of view of achieving the entire Austrian GHG-mitigation target (both ETS and Non-ETS) at minimum costs no GHG-abatement opportunities should be transferred from the Austrian Non-ETS-sector to the EU-ETS-market. This insight requires to searching for buyers of generated credits others than the EU-ETS market.

In addition to that, critics of economic incentive-based instruments argue that intended incentives might be interfered by non-financial barriers. This might lead to that financial incentives are not sufficient for individuals changing their behavior. This missed chance for an accelerated conversion of the energy system might also result in missing chances for first-mover- or competitive advantages. Therefore they argue – although C&C instruments might lead to efficiency losses at the beginning (due to diverse marginal abatement costs, etc.) – they provide higher certainty of accelerating the conversion of the energy system. This in turn makes first-mover- or competitive advantages more likely, whereas benefits from that might over-balance initial inefficiencies.

Conclusion: Considering economic efficiency, economic incentive-based instruments will have in many cases an advantage compared to C&C instruments. However, selling generated DOP-credits to the EU-ETS market might be inefficient, if the EU-ETS market is

²¹⁶ Peterson (2006), p. 1

²¹⁷ Peterson (2006), p. 1

“longer” than the Non-ETS-market. Furthermore, the higher uncertainty of economic incentive-based instruments compared to C&C instruments for converting the energy system more quickly might lead to missed chances like first-mover- or competitive advantages.

7.3.2 Need for public funds

The financial incentives of DOPs for carrying out GHG-abatements are provided by the corresponding markets for carbon offset credits. This means, no funds from the national budget are necessary for DOPs, apart from expenditures for providing the legal basis for DOPs or costs for enforcement. This is a crucial difference to pollution-control instruments like environmental subsidies or awareness building measures. However, to increase the economic attractiveness of DOPs it might be necessary to allow DOPs having also access to governmental subsidy schemes.²¹⁸

Conclusion: Referring to the need of public funds, DOPs are more advantageous compared to governmental subsidies or awareness building measures.

7.3.3 Flexibility

As new information arises, it may be beneficial to change or adapt pollution control instruments. A crucial question is, therefore, how flexible the instruments are, i.e., whether “the instrument is capable of being adapted quickly and cheaply as new information arises, as conditions change or as targets are altered”²¹⁹. In theory, framework conditions for DOPs, governmental subsidies as well as taxes or C&C instruments could be changed quite quickly as new information arises – only the frameworks of emission trading schemes are fixed for certain periods of time.

However, reality considerably differs from theory: Domestic Offset Projects need rather extended time horizons. On the one hand, DOPs might be complex and need fairly long time for planning.²²⁰ On the other hand, project developers need legal certainty that carbon offset credits could be generated during the entire time period promised by the government. This means, although quick changes of elements of pollution control instruments might be feasible in theory, frequent and unexpected adjustments might make project developers feel uncertain. For the attractiveness of a DOP-scheme therefore, framework conditions of DOP-schemes should not be easily changeable.

The same certainty over a longer period of time is necessary for feed-in-tariffs. However, governmental subsidies or taxes could be changed more flexible, although this might not be easy for politicians. Probably most flexible are awareness building measures, which could be adapted quickly as new information arises without harming the reliability of the instrument.

Conclusion: Referring to flexibility, many other pollution-control mechanisms are more flexible than DOP-schemes.

²¹⁸ See chapter 5.2.4

²¹⁹ Perman et al. (2003), p. 203

²²⁰ E.g. methodologies for MRV have to be developed

7.3.4 Need for the government to possess certain information

Before introducing a pollution control instrument, it is crucial to know “how much information the instrument requires that the control authority possesses, and what the costs of acquiring it are”²²¹. For instance, which information might be necessary for an effective operation of the instrument or which costs incur for possessing appropriate information.

The levels of tax rates on energy use or subsidy rates have to be determined by the government. To ensure that these pollution control instruments provide the right incentives for certain sectors, the government has to possess information about missing incentives in each of these sectors. For instance, the government has to decide which technologies should be subsidized and to which extent. This is similar to command & control instruments, where the government is required to know which legal specifications would lead to additional reductions in energy use. Also, for successful awareness building measures, knowledge about information gaps in different sectors might be necessary, specifically on which kind of information should be provided for a specific sector.

This essentially stands in contrast to the pollution control instrument “Domestic Offset Projects”. The government is not required to possess information about cheap abatement options. Instead, DOPs focus on advanced information of various market actors for cheap GHG-abatement options. It is therefore not the government but project developers who are required to have knowledge about funding gaps of certain project-types.

However, as mentioned in chapter 5.2, DOP-schemes might imply certain risks for the government. The government could therefore be willing to be insured against these risks, which would require possessing certain information.²²²

Conclusion: Regarding the informational requirement of the government DOPs are more advantageous compared other pollution-control instruments such as subsidies, taxes, feed-in-tariffs or awareness building measures. However, to insure against certain risks of DOPs the government might still need certain information.

7.3.5 Competition for cheap abatement options

Within the European climate policy, responsibility for achieving certain abatement targets is shared. On the one hand, GHG-emissions of certain industrial installations and fossil fired power plants are covered by the European emission trading scheme (EU-ETS). These installations²²³ are responsible for achieving their installations’ specific GHG-emission targets. For the rest of the GHG emissions, i.e., those from the residential sector, transport, SMEs, agriculture and landfill (Non-ETS), the government ultimately has to take care that all of them are covered by a respective amount of AAUs.

²²¹ Perman et al. (2003), p. 203

²²² E.g about the types and magnitudes of risks

²²³ Combustion plants (>20 MW), oil refineries, coke ovens, iron and steel plants as well as installations producing cement, glass, lime, bricks, ceramics, pulp and paper

Because of restricted budgets and/or the rationale to keep costs for climate protection as low as possible, the government as well as facilities covered, e.g., by the EU-ETS intend to achieve their particular targets at least costs. That means the government as well as mentioned installations (represented by developers of DOPs) are looking for cheapest abatement options. If, however, DOP-developers are allowed to capture abatement potential from Non-ETS sectors, the government might not be able any more to use all cheapest abatement options for its own compliance with international climate protection targets.

Therefore, at evaluating DOPs, an essential question arises: Could DOPs lead to a competition for cheap abatement options between the government and project developers? In other words: Would DOPs lead to a loss of cheap GHG-abatement potential otherwise tapped by the government to achieve its international climate protection targets?

Existing pollution control instruments do not lead to any competition for cheap abatement options: all GHG-reductions raised by existing pollution control instruments are one step ahead to achieve the government's climate protection target. DOPs do not lead to this competition either, as DOPs are intended – by definition – to just exploit GHG-abatements which would not have been exploited otherwise by existing instruments and regulations. However, the government may argue that GHG-abatement potential raised by DOPs would have been also raised by other pollution control instruments at a later date. Thus, in the long run, competition for cheap GHG-abatement options could arise with DOPs based on JI. Therefore, the government must implement certain provisions to be compensated for the loss of cheap GHG-abatement options. Also, it may restrict DOPs to certain project-types where conventional instruments are not likely to raise GHG-abatement potential to a sufficient extent.

Nevertheless, it has to be added that even if this problem of competition for cheap abatement options exists, reductions of GHG-emissions from certain projects will also occur after the crediting period.²²⁴ These GHG-abatements will then – after the crediting period – always be assigned to governmental climate protection efforts.

Conclusion: In contrary to existing pollution control instruments, DOPs based on JI may lead to that the government has to compete for cheap GHG-abatement options with private project developers. This problem does not evolve at DOPs based on the voluntary carbon offset market²²⁵.

7.3.6 Support to achieve governmental climate protection targets

Closely connected to the previously described criterion is the question whether DOPs also support climate protection targets of the government. A pollution control instrument supports achieving the governmental climate protection targets if real GHGs are reduced while AAUs are not or only to a lesser extent get transferred from the governmental AAUs-budget.

²²⁴ In the case of Domestic JI

²²⁵ At standards where no AAUs are transferred

This is especially true if DOP-schemes are based on Joint Implementation (JI). As mentioned already, DOPs based on JI reduce GHGs, but reduce also the government's budget of AAUs by the same extent. Therefore, a DOP-scheme based on JI is a zero-sum game – neither a support nor an impediment for achieving government's climate protection targets. However, the government could strengthen its position by allowing DOPs based on JI only under certain provisions²²⁶. In that case, the government could benefit from this category of DOPs.

Contrary to that, DOP-schemes based on the voluntary carbon offset market are not connected to the "official" climate regime (currently, the Kyoto-regime). This implies GHG-abatements under this scheme do not affect, i.e. reduce a country's AAU-budget²²⁷. As DOP-schemes based on the voluntary carbon offset market therefore reduce a country's emissions-gap, this category of DOP-schemes supports the achievement of governmental climate protection targets. This is also true for existing pollution control instruments as taxes, subsidies etc.

Conclusion: Referring to the considered criterion, DOP-schemes based on JI are inferior to DOP-schemes based on the voluntary carbon offset market or other, existing pollution control instruments. However, the government could include certain provisions that DOP-schemes based on JI could also be beneficial for the government.

7.3.7 Conclusion

Table 15 gives an overview of the comparison of DOPs with other, relevant pollution control instruments. It is distinguished between the different categories of DOPs – either based on JI or based on the voluntary carbon offset market. Colors show the inferiority (red) or superiority (green) of DOPs to other considered instruments. The white areas show that DOPs are indifferent compared to other considered instruments. It is important to note that this Table only gives a rough overview. A more detailed explanation is given in prior subsections 7.3.1 - 7.3.6 .

²²⁶ These provisions may be discounting of issued ERUs or partly siphoning off project developer's revenues of credits-sales. A detailed discussion of these provisions will be provided in chapter 9

²²⁷ This is not true for all certification standards. For instance, the "Voluntary Carbon Standard" requires the cancellation of AAUs when generating carbon offset credits (See for instance article "VCS to allow projects hosted in Canada without cancellation of Kyoto emission allowances"; July 24, 2009; www.CO2-handel.de). However, this is not required for some other standards. See for further details: Kollmuss, Zink, Polycarp (2008)

Table 15 Comparison of DOPs with other, relevant pollution control instruments

Criteria		Env. subsidies	Env. taxes	Awareness building	C&C instruments
Cost efficiency	DOP (JI)				
	DOP (VOC)				
Need for public funds	DOP (JI)				
	DOP (VOC)				
Flexibility	DOP (JI)				
	DOP (VOC)				
Need for govt. Information	DOP (JI)				
	DOP (VOC)				
Competition for cheap abatements	DOP (JI)				
	DOP (VOC)				
Support for govt. GHG targets	DOP (JI)				
	DOP (VOC)				

DOPs are better than ...
DOPs are equal to ...
DOPs are worse than ...
DOPs are partly worse than ...

Source: own illustration

The analysis has shown that referring to cost efficiency economic incentive-based instruments – like DOPs, subsidies or taxes – are superior to command and control (C&C) instruments. However, C&C instruments might be also efficient in the long run if GHG-abatements would not be achieved with certainty by economic incentive-based instruments.

Referring to the need for public funds, DOPs are superior to environmental subsidies or awareness building measures as financial incentives are provided by the markets for carbon offset credits but not by public funds. However, to stimulate the potential for DOPs an access for DOPs to governmental subsidy schemes may be advantageous.

Referring to flexibility, other pollution-control mechanisms are more flexible than DOP-schemes.

GHG-abatements achieved due to DOPs do not require any governmental information. On the contrary, other considered pollution control instruments as subsidies, taxes, feed-in-tariffs or awareness building measures require governmental information that incentives can be set appropriately. Hence, in respect to this criterion DOPs are more advantageous than other considered instruments. However, to insure against certain risks of DOPs the government might still need certain information.

Considering the criterion “competition for cheap GHG-abatement options”, it has to be distinguished between DOPs based on the voluntary carbon offset market and DOPs based on JI. DOPs based on the voluntary carbon offset market²²⁸ do not cause any competition for cheap abatement options. Therefore it can be evaluated equally to the other considered instruments. However, DOPs based on JI may lead to a competition.

²²⁸ ... In the wise established already in Austria

Referring to the support of DOPs to achieve a short-term governmental climate protection target, DOPs based on the voluntary carbon offset market do assist this target. Therefore this category of DOPs has to be ranked equally to other considered instruments. However, DOPs based on JI reduce the government's budget of AAUs: Considering that GHG-abatement options usable for achieving the governmental target could be reduced²²⁹ or cheating²³⁰ might happen, achieving the governmental targets might be hampered. Therefore, DOPs based on JI would need to include certain provisions in order to be ranked equally to other considered instruments.

²²⁹ Within a longer period of time

²³⁰ In this sense that DOPs could be claimed as additional although they were non-additional in reality

8 Interactions of DOPs with other pollution control instruments

This chapter analyzes how the instrument “Domestic Offset Projects” interacts with other, existing types of pollution control instruments. The pollution control instruments in question are corresponding emissions trading schemes (e.g., EU-ETS), subsidies, taxes on energy use, awareness building measures and command & control measures such as minimum technology requirements.

8.1 INTERACTIONS OF DOPS WITH THE EU-ETS

Using offset credits generated by DOPs have the potential to reduce abatement costs within the EU-ETS, especially if cost-efficient abatement opportunities in the EU-ETS are not carried out due to other restricting, non-financial barriers. However, the interactions of interest now – the impacts on respective GHG emissions – should be avoided: DOPs should not also lead to GHG-reduction of ETS installations, as this results in double counting of emission reductions.²³¹

Conclusion: DOPs must neither be carried out in installations covered by the EU-ETS nor include project-types which lead to the double counting calculation error.

8.2 INTERACTIONS OF DOPS WITH SUBSIDIES

The mode of operation of DOPs is identical to subsidies: They both change individuals' behavior on a voluntary basis by providing economic incentives. That means, if potential GHG-mitigation measures are not implementable economically, i.e., if costs²³² of implementation exceed savings from reduced energy demand, this type of instruments can fill the financial gap and enable the implementation of GHG-mitigation measures.

Austria has comprehensive subsidy coverage in general as well as in the area of climate protection and environment preservation, in particular²³³. However, public authorities are unlikely to possess perfect information about requirements for funding of potential GHG-mitigation projects²³⁴. This implies, for certain GHG-abatement options existing subsidy-schemes may precisely fill the gap of funds necessary for realization. For some other options, however, subsidy-schemes may underestimate or overestimate the need for subsidies and therefore provide less or more subsidies than required. Interactions of DOPs with existing

²³¹ Problem of double counting, see also chapter 5.2.3

²³² This also includes costs which are necessary to remove non-financial barriers by compensating for inconveniences

²³³ See Sattler, Lang, Lutter (2005)

²³⁴ See for example Perman et al. (2003); p. 213

subsidies might arise if DOPs could provide additional funding for potential GHG-mitigation projects where existing subsidies are not sufficient.²³⁵

The possible cases for interactions of DOPs with existing subsidies are displayed in Figure 21. The blue rectangles schematically show GHG-abatement options, whereby on the X-axis GHG-mitigation potential and on the Y-axis marginal abatement net-costs²³⁶ of these options are displayed.

Figure 21 Interactions of Domestic Offset Projects with existing subsidies

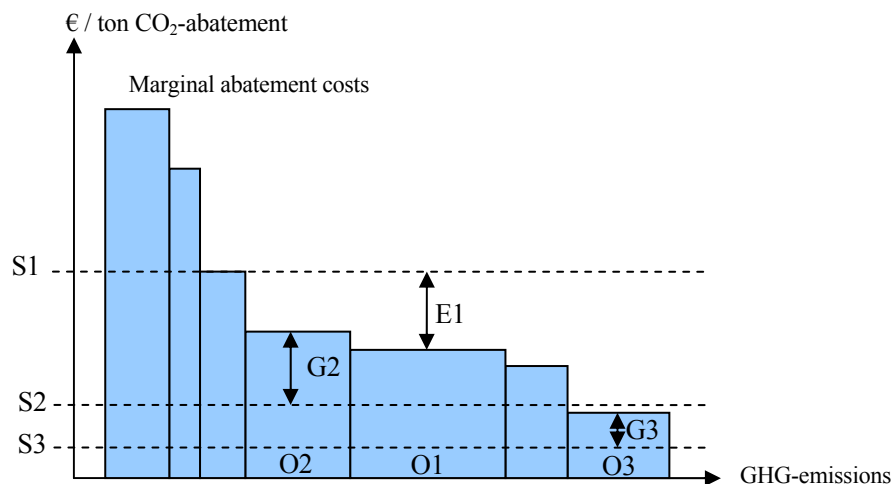

Source: own illustration

There might be certain GHG-abatement options which are already subsidized either sufficiently or more than necessary. This means, further funds for carrying out these options are not required. Hence, these options could not be carried out as DOPs, as DOPs are required to stimulate additional GHG-abatements. Therefore no interactions of the subsidy-scheme with DOPs would evolve. This case is also shown graphically at abatement option O1. A corresponding subsidy rate S1 would lead to an excess of subsidies by E1 already.

The situation would be contrary to that where subsidy rates could not remove financial barriers completely for carrying out abatement options. This is shown at the example of abatement option O2, where the corresponding subsidy rate of S2 leads to the financial gap of G2. Allowing this option to be accomplished as DOP – therefore generating sellable offset credits and thus revenues – option O2 might be attractive enough to be carried out. Thus, it can be observed that subsidies and DOPs mutually strengthen their effects.

²³⁵ This may refer also to the need for funds to overcome barriers like risk aversion and insufficient human resources to plan and accomplish GHG-mitigation measures

²³⁶ The term net-costs of GHG-abatement options is assigned to cost of implementation minus cost savings e.g. due to energy savings. Therefore net-costs are the requirements for subsidies in order that GHG-abatement options could be carried out.

From the viewpoint of project developers it is wise to carry out the cheapest abatement options first. This is also true from the overall economic point of view – when leaving co-effects of GHG-abatement measures out of consideration²³⁷, which might be necessary in achieving a climate protection target in the short-term. Thus it might be wise to carry out those projects facing the smallest financial gap. This case is shown by option O3, facing only a small financial gap G3. However, although choosing these options first might be most cost efficient, proving additionality for these projects might be also the most challenging among abatement options.

A crucial question in this context is often²³⁸ whether DOPs should get access to governmental subsidy schemes at all. This could be approved without any doubt in the case of DOP-schemes based on the voluntary carbon offset market – as long as credits would be still additional. This category of DOPs assists to achieve the government's climate protection target. More critical in this context are DOPs based on JI. At this category of DOPs, the government would grant subsidies to abatement projects, but would not benefit in the short-term from these projects as they cause a transfer of AAUs from the government to DOP-developers.²³⁹

Conclusion: In cases where existing subsidies (more than) sufficiently cover required funding for GHG-abatement options, DOPs cannot be accomplished (additionality requirement) and therefore no interactions arise. Interactions arise where subsidies alone would not be sufficient. In this case, however, effects of subsidies and DOPs would be mutually strengthened. Specific attention should be laid on the question whether DOPs should get access to governmental subsidy schemes. Whereas this could be approved for DOPs based on the voluntary carbon offset market, DOPs based on JI would need to include certain provisions²⁴⁰ that also the government benefits from these projects.

8.3 INTERACTIONS OF DOPS WITH TAXES ON ENERGY USE

The mode of operation of taxes and subsidies is quite similar as they operate through modification of relative prices.²⁴¹ As DOPs operate by stimulating GHG-mitigation measures through financial incentives, in a way subsidies do, it can be inferred that DOPs also operate similar to taxes on energy use.²⁴²

When imposing a tax on energy use or subsidizing options that reduce GHG-emissions, it becomes profitable for individuals to reduce their energy demand as long as marginal costs for that do not exceed anticipated marginal tax payments or anticipated marginal revenues of

²³⁷ Compare Pretenthaler, Steiner, Schlamadinger (2006)

²³⁸ See also the discussion of DOP-schemes in other countries

²³⁹ This requires certain provisions, that the government also benefits when assigning public funds

²⁴⁰ See chapter 9

²⁴¹ See Perman et al. (1999), p. 307

²⁴² Although taxes and subsidies exhibit this fundamental symmetry, they are not equivalent in all respects: “The short-run incentive effects of an emissions tax and an abatement subsidy are essentially the same. However, the long-run effects of subsidies may be different from those of taxes, given their different distributional consequences.”, Perman et al. (1999), p. 307. Whereas DOPs lead to an increase of income for implementers of mitigation projects, taxes, in the contrary, result in a transfer of income from potential implementers of mitigation projects to the government. See also Perman et al. (2003), p. 220

subsidies. GHG-emissions reduced by taxes could be even more reduced by the incentives of DOPs. The magnitude of additional effects of DOPs would substantially rely on the cost increases per additional unit of GHG-abatements.

Figure 22 shows this interaction of taxes on energy use and the subsidizing character of DOPs:

Figure 22 Interactions of Domestic Offset Projects with taxes on energy use at relatively low marginal abatement costs

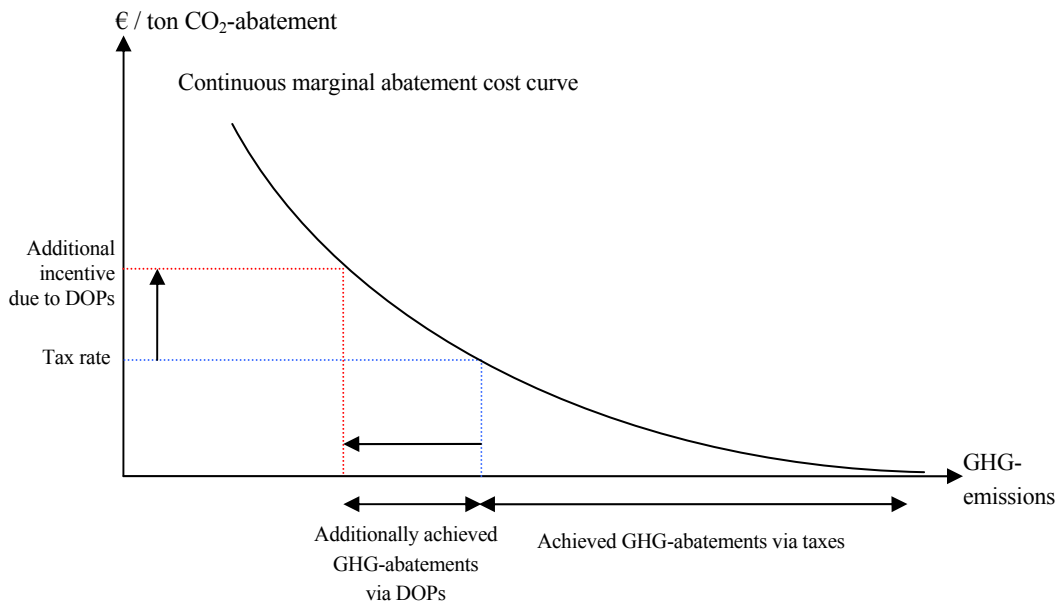

Source: own illustration

Figure 22 shows the marginal abatement cost curve of GHG-abatement options. Imposing a tax on energy use may already result in more energy efficient measures and -behavior. If, in addition to taxes, subsidies in the form of DOPs were implemented as well, extra measures for energy savings become profitable for individuals. This situation would imply an even higher GHG-reduction.

The magnitude of additional effects due to DOPs would substantially rely on the cost increases per additional unit of GHG-abatements, i.e. on the shape of the marginal abatement cost curve. Facing high costs per additionally reduced ton of greenhouse gases may result in limited additional GHG-reductions achieved by DOPs, as depicted in Figure 23.

Figure 23 Interactions of Domestic Offset Projects with taxes on energy use at relatively high marginal abatement costs

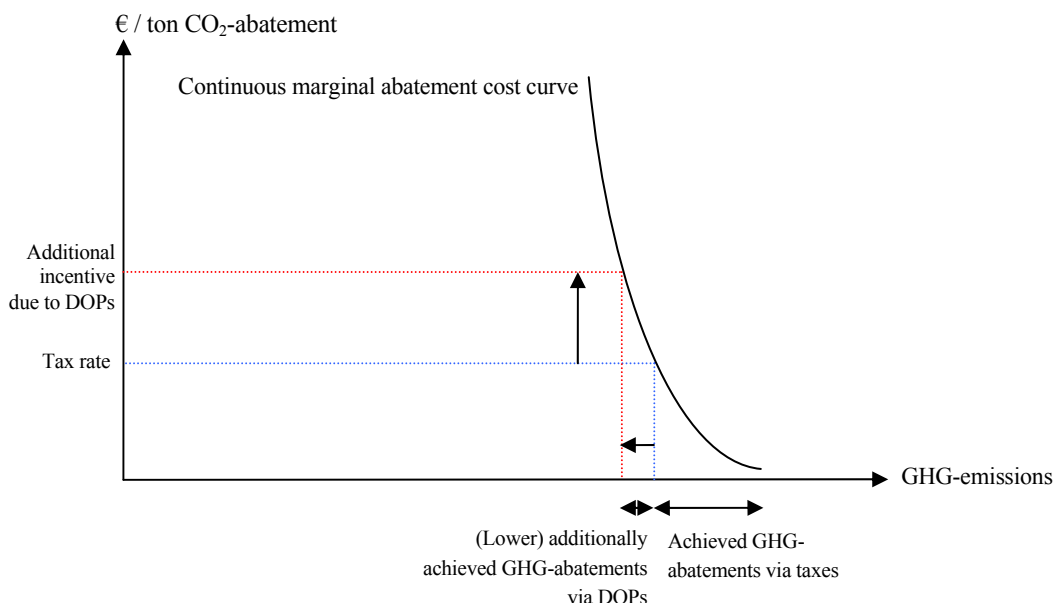

Source: own illustration

Conclusion: Taxes on energy use and DOPs would mutually strengthen their effects on GHG-abatement. Furthermore, achieved GHG-abatements by implementing DOPs additionally to taxes would substantially rely on the shape of the marginal abatement cost curve.

8.4 INTERACTIONS OF DOPS WITH AWARENESS BUILDING MEASURES

On the one hand, implementation of GHG-mitigation projects depends on economic criteria, i.e., whether possible savings exceed technical implementation costs. On the other hand, it also depends on whether the costs which are not directly associated with technical implementation expenses are also covered. These costs are, for instance, the time spent on searching for information about GHG-mitigation options or opportunity costs of implementing these options. These “other” costs could impede the implementation of GHG-abatement options although they look profitable if only technical implementation costs were considered.

Awareness building measures or providing information could, at least, partly reduce these “other” costs. Whether awareness building measures coupled with DOPs would lead to an additional benefit compared to only implementing DOPs relies on the effect of awareness building measures on marginal abatement costs of abatement options. It can be observed, that the combination of both instruments might be beneficial especially if awareness building measures are suitable to substantially remove informational barriers.

This is shown in the figure below: as awareness building measures reduce aforementioned “other” costs, marginal abatement costs of GHG-mitigation measures are reduced, which leads to GHG-abatements. If, in addition to that, financial incentives via DOPs were provided, the magnitude of achieved GHG-abatements could increase even more. Therefore, a simultaneous application of both instruments may provide synergy effects.

Figure 24 Interactions of Domestic Offset Projects with effective awareness building measures

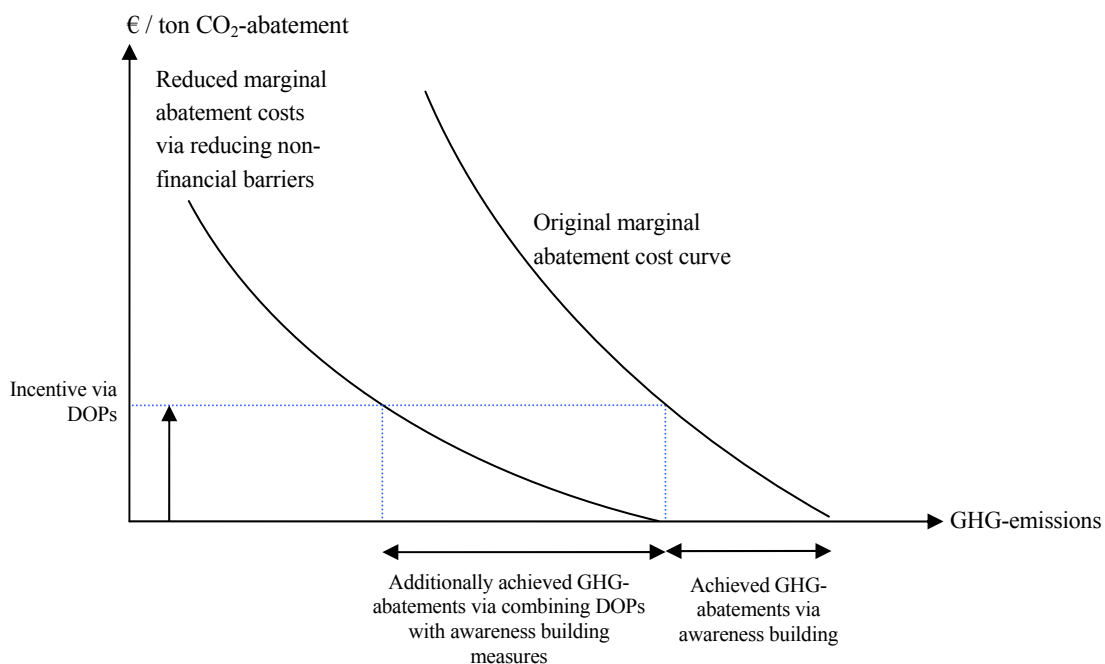

Source: own illustration

The effectiveness of awareness building measures and DOPs highly depends on the shape of the marginal abatement costs curve. Showing a sharply steep increase of the curve also after awareness building measures have been carried out²⁴³, a combination does not provide much synergy. This case is displayed in Figure 25.

²⁴³ This might be an indicator that missing awareness or missing information was not the barrier of GHG-abatements

Figure 25 Interactions of Domestic Offset Projects with ineffective awareness building measures

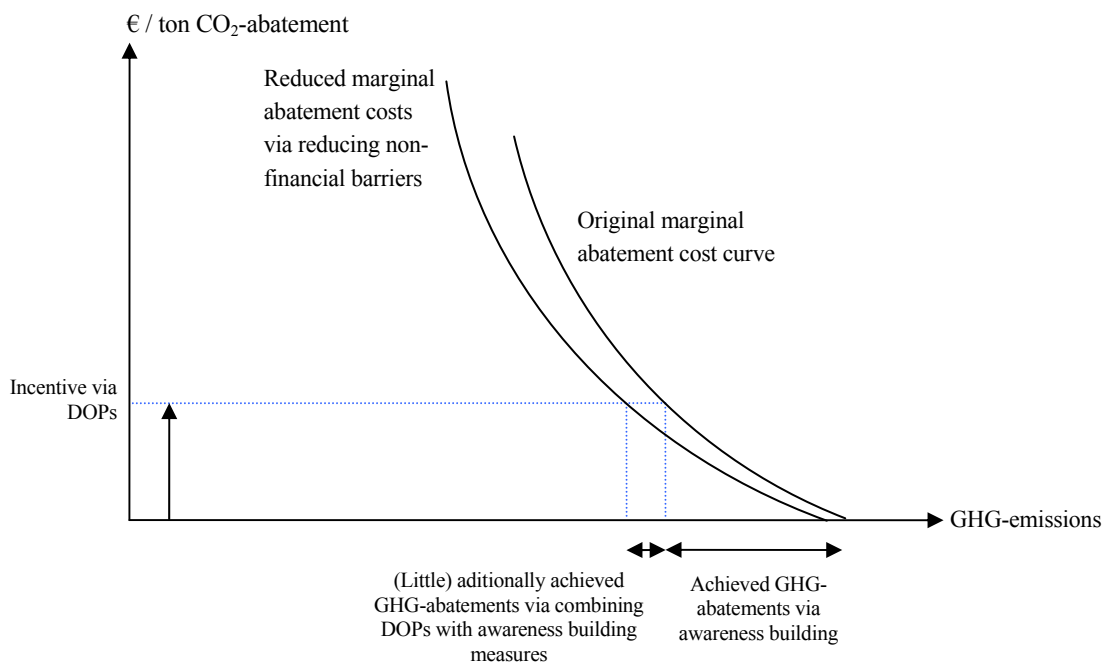

Source: own illustration

Special attention has been laid on measuring additionality of DOPs when combining this instrument with awareness building measures.

Conclusion: Combining DOPs with awareness building measures would lead to synergetic effects. These synergetic effects arise especially if aforementioned “other” costs²⁴⁴ would be the barriers for carrying out GHG-abatements and if awareness building measures are suitable to substantially reduce those barriers.

8.5 INTERACTIONS OF DOPS WITH COMMAND & CONTROL MEASURES

One of the essential criteria for DOPs is that intended projects should not be already enforced by legal requirements. Because of that, legal requirements, for instance command & control (C&C) measures such as minimum technological requirements restrict the potential for DOPs.²⁴⁵

²⁴⁴ e.g. lack of information about GHG-abatement options; opportunity costs of implementing these options

²⁴⁵ It has to be noted that a reasonable instrument mix may include in certain cases also C&C instruments. This is true especially if individuals do not act rationally or if information is not available.

This is shown exemplarily in Figure 26 where C&C measures already impose the implementation of certain GHG-mitigation options²⁴⁶. Therefore, a certain share of the entire portfolio of GHG-abatement options is excluded from being raised by DOPs.

Figure 26 Interactions of Domestic Offset Projects with Command & Control measures

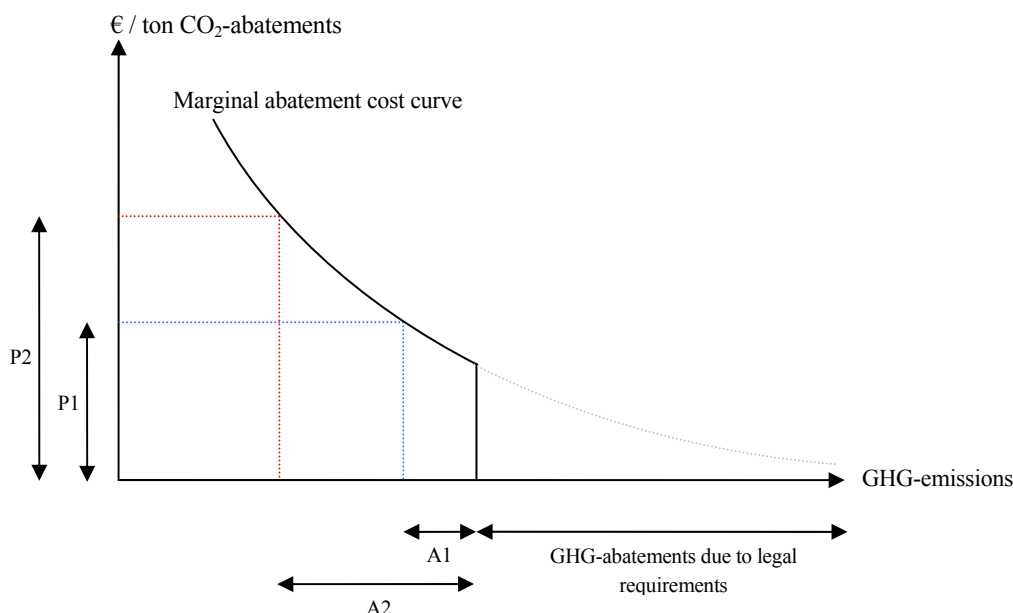

Source: own illustration

Figure 26 schematically shows the marginal abatement cost curve within a certain sector whereof certain GHG-abatements are already achieved by legal requirements. DOPs can affect GHG-emissions only beyond this level. The effect of DOPs additional to C&C measures depends on achievable revenues from offset credits sales. At a price of P1 additional GHG-abatements of A1 could be achieved. At a higher price P2 more GHG-abatements of A2 could be achieved.

Similar to the previous analyses of interactions also in this case achievable GHG-abatements rely on the shape of the marginal abatement cost curve: A steeply increasing marginal abatement cost curve²⁴⁷ shrinks also the potential for GHG-abatements due to DOPs.

Conclusion: The presence of C&C instruments limits the potential for GHG-abatements by DOPs. This potential depends on the price for offset credits and the shape of the marginal abatement cost curve.

²⁴⁶ It is assumed only for simplifying the illustration that C&C measures focus on low-cost abatement options, whereas for DOPs only higher-cost options would be available. This might not be true in reality as the government is not likely to possess about complete information (see Perman et al., 2003, chapter 12)

²⁴⁷ i.e. if relatively few low-cost options are available

8.6 CONCLUSION

The analysis has shown that Domestic Offset Projects never lead to a weakening or conversion of the effects intended by other pollution control instruments. However, the combination of environmental subsidies with DOPs based on JI would – without further provisions – lead to the result that GHG-abatements would be stimulated also by public funds, but achieved GHG-abatements would not be assigned to governmental efforts for achieving the national climate protection target.

The magnitude of GHG-abatements additionally achieved by combining existing pollution control instruments and DOPs would rely on the costs for each saved ton of CO₂eq. This means, the amount of additionally achievable GHG-abatements rely on the shape and increase of the marginal abatement cost curve.

Additionality of DOPs should always be considered as crucial. However, especially at combining DOPs with awareness building measures, the fraction of abatement effects induced by DOPs might be more difficult to separate compared to combining DOPs with other pollution-control instruments.

9 Designing and comparing different DOP-schemes

As mentioned earlier, DOP-schemes could be designed to create either voluntary carbon offset credits or Emission Reduction Units (ERUs). However, as described in chapter 7 both categories of DOP-schemes face weaknesses. On the one hand, DOP-schemes based on the voluntary carbon offset market are indeed beneficial also for the government in achieving its climate protection targets. As prices for credits might be too high to attract many buyers, however, provisions are needed to make this “commodity” more attractive. On the other hand, DOP-schemes based on JI may indeed not suffer sales problems of internationally tradable credits. However, at this category of DOP-schemes the government faces certain risks which may impede to achieve the governments climate protection targets. Thus, DOP-schemes based on JI must include certain provisions to compensate the government for certain risks or losses and to create advantages for the government.

In the following subsections, specifications of the two discussed categories of DOP-schemes are provided. These specifications include provisions to remove aforementioned weaknesses. The first discussed specification is a DOP-scheme based on the voluntary carbon offset market with governmental involvement. After that, three specifications will be introduced based on “Domestic JI”: one with partly siphoning off economic benefits of ERU-sales, another one with discounting of issued ERUs and the last one with the government as an investor.

9.1 OPTION 1: DOP-SCHEME BASED ON THE VOLUNTARY CARBON OFFSET MARKET INCLUDING A TENDER FOR PROJECTS

This design option of a DOP-scheme is based on generating credits for the voluntary carbon offset market. As mentioned above, GHG-abatements would be carried out by private actors. Generated credits could be sold on the voluntary carbon offset market. Entire revenues from these sales are earned by involved private actors (and if necessary, partly, by an intermediary) and used to cover the costs of GHG-abatements. The government benefits from a real reduction of GHGs without issuing AAUs for these reductions.

Figure 27 Schematic illustration of a DOP-scheme based on generating voluntary offset credits

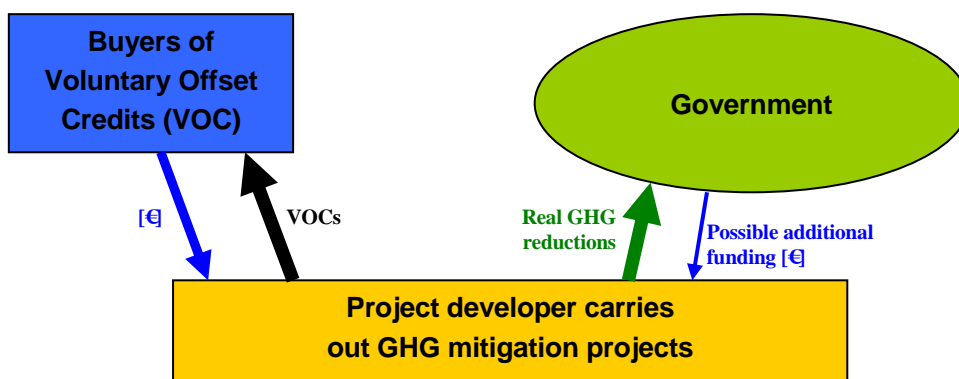

Source: own illustration

As mentioned in chapter 7 an Austrian voluntary carbon offset market already exists.²⁴⁸ However, traded volumes are currently rather minor.²⁴⁹ Hence, provisions are needed to make voluntarily offsetting of carbon emissions more attractive for consumers. This may work via increasing the opportunities where voluntary offset credits (VOCs) could be purchased. Consumers should get the opportunity to offset their GHG-emissions not only for flights²⁵⁰ but also at other occasions as rail journeys, cab rides etc. Experiences at offsetting carbon emissions from flights have shown that 7 % to 8 % of all passengers are willing to voluntarily pay a bit more for getting “green flights”.²⁵¹ Besides offering frequent opportunities for voluntarily offsetting carbon emissions, prices for credits must match the willingness to pay (WTP) of consumers. As VOCs are no luxury goods a negative price-demand relation for VOCs can be assumed. This means, the lower the price for credits the higher might be the demand. At this stage, the government comes into play: The government might subsidize credits to an extent that credits could be offered at a price the mass of consumers are willing to pay.

Using public funds for subsidizing VOCs to lowering their sales prices might be twofold beneficial. Firstly, in helping the voluntary carbon offset market for trading higher volumes, also private money is incorporated for achieving the governmental climate protection targets. Secondly, the government might be specifically interested in particular project-types to be accomplished for generating VOCs, i.e. those project-types which also cause other benefits, e.g., promoting technological innovation. Lowering the costs of VOCs by subsidies may make certain project-types more profitable and therefore more attractive also for developers of VOCs.

At spending public money for enabling certain project-types to be accomplished by developers of VOCs, the government might be interested to maximize its utility of its

²⁴⁸ E.g. Climate Austria, www.climateaustria.at

²⁴⁹ In 2009 donations have been made which lead to 10,592 tons of CO₂-reductions over the entire life time of investments; Kommunalkredit Public Consulting [4] (2009), p. 11

²⁵⁰ Passengers of the Austrian Airlines can offset their carbon emissions caused by the flight

²⁵¹ Kommunalkredit Public Consulting [2] (2008), p. 6

supportive actions. This is done by maximizing the amount of GHG-abatements supported by its subsidies. This means, within the portfolio of project-types especially interesting for the government, the government should choose those projects which claim the lowest need for additional subsidies by the government. In order to avoid cheating or arrangements among VOC-developers, the government could establish an environment of competition among project applicants. This could be done by a call for tenders for GHG-mitigation projects where available funds would be limited and the choice for projects to be additionally subsidized would be driven only by the amount of additionally requested funding per ton of CO₂-abatement.²⁵²

This call for tenders might be a welcomed “instrument” to generate improved knowledge about potential lacks of funding for certain project-types.

Conclusion: This specification of the DOP-scheme based on the voluntary carbon offset market might lead to an increased demand for VOCs. This would result in a step forward in achieving the governmental climate protection targets, whereby increased amounts of private money are incorporated. Additionally, used public funds for helping the voluntary carbon offset market to develop would be also beneficial for the government, both for achieving its (long and short term) climate protection targets but also for getting better knowledge about potential funding gaps.

9.2 OPTION 2: DOP-SCHEME BASED ON DOMESTIC JI WITH FRACTIONAL TRANSFER OF ECONOMIC BENEFITS

This DOP-scheme design option is based on the crediting mechanism ‘Domestic JI’ discussed in section 7.2. As a reminder, private actors select and carry out GHG-abatement projects. Achieved GHG-abatements are certified according to the JI standard and internationally tradable credits – Emission Reduction Units (ERUs) – could be generated. Revenues from credits’ sales are used to cover costs of projects as well as generating entrepreneurial profits for project developers.

²⁵² This approach is based on the approach used by the Swiss Stiftung Klimarappen

Figure 28 Schematic illustration of a DOP-scheme based on Domestic JI with fractional transfer of economic benefits

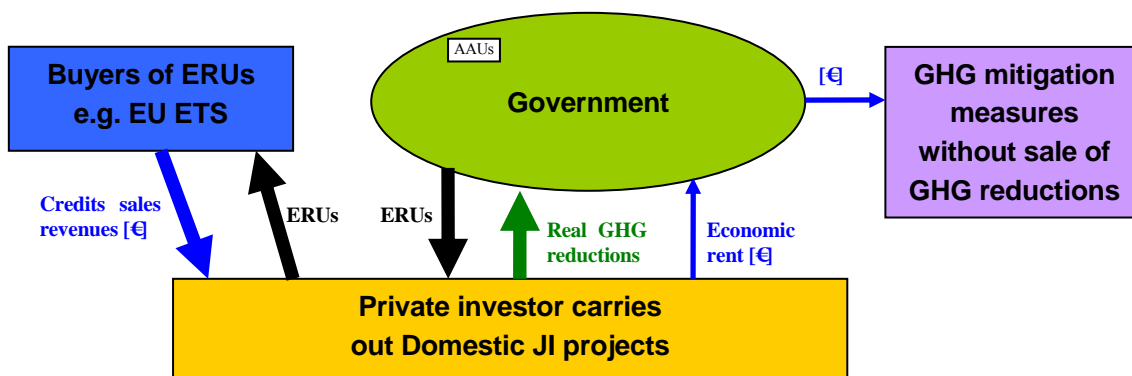

Source: own illustration

However, the government faces certain risks: Some GHG-abatement projects might be non-additional in reality, although strict additionality tests were applied. This would cause a loss of government's AAUs without corresponding additional reductions of GHG-emissions.²⁵³ Also, if private DOP-developers raise cheap abatement possibilities already due to DOPs, this GHG-abatement potential is not usable by the government any more to achieve its own emissions reduction targets (competition for cheap abatement possibilities).²⁵⁴ On the other side, sales revenues of generated credits would be earned only by private DOP-developers. However, this would imply that private DOP-developers earn all profits from credits' sales – i.e. “reap” all economic benefits – while the government faces the risks of a more difficult or more costly achievement of its climate protection targets. This would make the government worse off from the climate policy perspective. Thus, a DOP-scheme based on JI has to include a provision to compensate the government for these risks.

Therefore this DOP-scheme option is designed in a way that the government siphons off a share of the profits earned by private DOP-developers. This would work as a general insurance for the government against the risk of non-additionality and against the risk of achieving climate protection targets too costly. These revenues could be used to finance compensating measures against these risks. For instance, the government could induce additional emission reductions – also more expensive ones – which would not be converted into tradable carbon offset credits. The GHG-abatements of these compensating measures could then be added to governmental efforts of achieving its climate protection targets.

The level of the rate for siphoning off profits is a highly crucial one, leading to a trade-off between financial attractiveness of DOPs and appropriate compensation for risks faced by the government. This trade-off is discussed with the help of Figure 29:

²⁵³ See subsection 5.2.1

²⁵⁴ See subsection 5.2.2

Figure 29 Schematic illustration of effects on GHG abatements of DOPs caused by a fractional transfer of economic benefits from the investor to the government

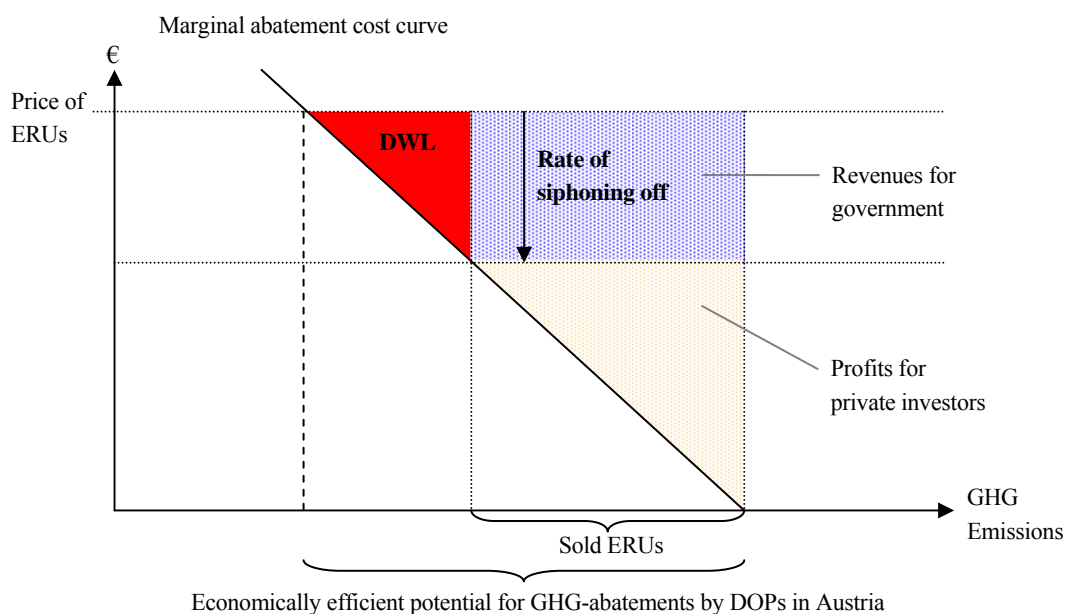

Source: own illustration

For instance, if the chosen rate would be rather low the amount of DOPs might not substantially shrink compared to the case without siphoning off profits to a certain extent. However, in that case the government might face the problem of not being compensated completely for mentioned risks. On the contrary, a rate too high would indeed increase the probability that the government is fully compensated for any risks and disadvantages of DOPs. However, this would lower the financial attractiveness of DOPs and could therefore lower the potential of DOPs considerably. For ultimately deciding about an appropriate value of the mentioned rate, a risk analysis should be conducted. The costs of risk bearing (CORB)²⁵⁵ should be covered by revenues from the siphoning off rate. The CORB expresses in monetary terms the utility difference of an actor – in this case the government²⁵⁶ – “from being in a risky as opposed to an actuarially equivalent certain situation”.²⁵⁷ Along similar lines with ad-valorem taxation, this siphoning off of profits from ERU-sales would certainly cause a loss of welfare (dead weight loss – DWL). However, one should keep in mind that not raising this GHG-potential would lead to a higher loss of welfare, namely the amount of the economic rent (amount siphoned off) and the profits remaining for private actors.

Conclusion: This DOP-scheme option is designed to financially compensating the government for potential risks going along with the uncertainty of issuing ERUs also for non-additional DOPs. A crucial question is the choice of the rate for partly siphoning off profits

²⁵⁵ Compare Perman et al. (2003); p. 447

²⁵⁶ The government is assumed to be risk-averse in the context of achieving its GHG-mitigation target, as facing any problems in achieving it would lead – in the short term – to additional burden for the national budget as well as it might negatively affect the international credibility for Austria to its ability for achieving its target mostly by own actions.

²⁵⁷ Perman et al. (2003); p. 447

from DOPs. However, rather than getting only compensated for potential risks and thereby being indifferent from a governmental perspective between approving or not approving DOPs, the government could be even better off at approving DOP in the presence of a fairly high market price for ERUs. This means, earning revenues from siphoning off could exceed necessary amounts for insuring against risks while potentially not lowering the attractiveness of DOPs considerably. In that case the government would not only be compensated for risks, but also additional funds would be available for promoting governmental climate policy activities. Therefore this DOP-scheme option might be appropriate if still many opportunities for GHG-abatements in Non-ETS sectors are available, but public funds would not be sufficient to stimulate this potential.

9.3 OPTION 3: DOP-SCHEME BASED ON DOMESTIC JI WITH DISCOUNTING OF ALLOCATED ERUS

This design option of DOP-schemes is also based on the aforementioned crediting mechanism ‘Domestic JI’. However, this option does not envisage monetary compensations for certain disadvantages of DOPs to the government, like option 2. To ensure that DOPs serve also in the interest of the government, this design option includes another provision. The government benefits and insures itself against non-additionality risks by discounting the amount of credits allocated.

Figure 30 Schematic illustration of a DOP-scheme based on Domestic JI with discounting of allocated ERUs

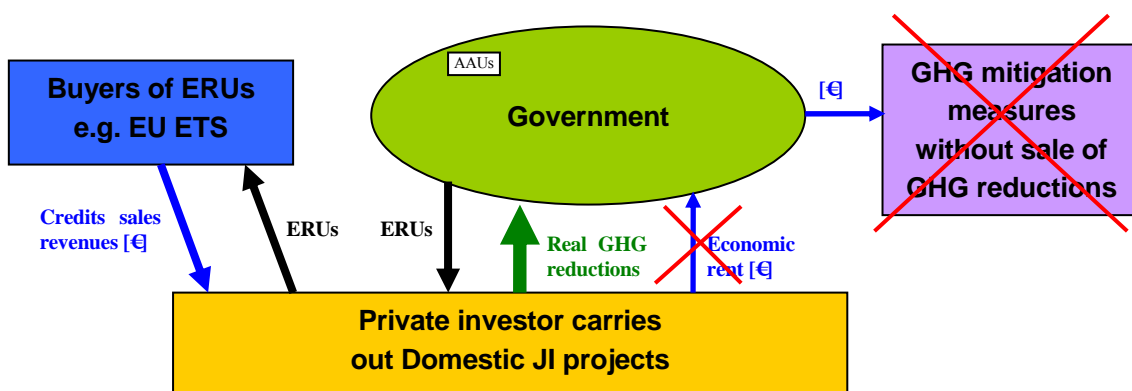

Source: own illustration

This option of DOP-schemes can be explained by Figure 30. Also at this option, private project developers apply the mechanism ‘Domestic JI’, i.e., GHG-abatement measures have to be accomplished, GHG-emission reductions are certified and thereby generated ERUs are sold. The provision against “non-additionality risks” is designed in a way that the amount of issued ERUs is smaller than its corresponding reduction of real GHGs. This means that the amount of issued ERUs is discounted by a certain rate. As less ERUs are issued – and

therefore less AAUs would have to be transferred from the government's AAU-account – than real GHG-emissions are supposed to be reduced, this procedure could imply one step further to achieve the government's climate protection targets. Thereby this provision can be seen – similar than option 2 – as an action where the government potentially also benefits from DOPs or, at least, is not affected adversely from them. The remaining, discounted amount of ERUs could then be sold by private actors and the revenues could be earned entirely by them. This also means that this DOP-scheme does not induce financial flows back from private project developers to the government as it is the case in option 2.²⁵⁸

As shown in Figure 31 discounting of issued ERUs is similar to partly siphoning-off profits from DOP-developers (option 2) with the only difference that the amount of GHG-abatements is not reduced in exchange for returning revenues from siphoning-off profits to DOP-developers. Suppose the government would hypothetically impose a tax on carbon offset credits. This would lower the revenues from ERUs a DOP-developer could accrue. In consequence, DOP-developers would decide to accomplish GHG-abatement measures only up to the level of A, thereby generating profits of ABC. Hypothetical tax revenues are shown by the area ABDE. However, at this option the government does not primarily intend to generate revenues from siphoning-off profits, but rather prefers that additional GHG-abatements were accomplished. Therefore, the government would offer to DOP-developers that they get exempted from this “siphoning-off tax” in exchange for further accomplishing GHG-abatement measures wherefore no ERUs are issued. The extent of further demanded GHG-abatements is determined by the discount rate, telling about the fraction from the overall GHG-abatements achieved by DOP-developers wherefore no ERUs are issued. DOP-developers would be willing to accomplish further GHG-abatements as long as costs for additionally achieved GHG-abatements are lower than the value of tax exemption. In that case, GHG-abatements of FG would be assigned to the government. The rest of achieved GHG-abatements, this is GC, could be traded by DOP-developers on the carbon offset market, thereby making profits represented by the area ACDE.

²⁵⁸ For a better understanding, compare also the magnitudes of arrows in Figure 30

Figure 31 Schematic illustration of discounting the amount of allocated ERUs

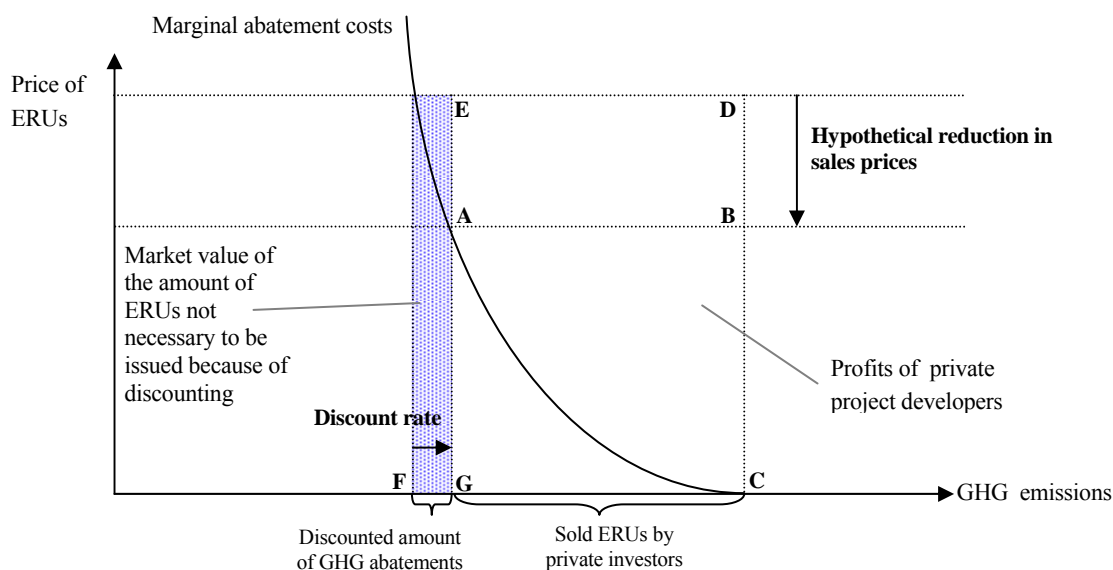

Source: own illustration

Alike at option 2, the choice of discount rate is a trade-off between fully compensating the government for faced risks versus providing a financially attractive opportunity for private project developers. Determining a fairly high rate would imply an unattractive situation for potential DOP-developers as the portion of GHG-abatements wherefore no ERUs (and therefore AAUs) are issued would be relatively high (blue dotted rectangle). Determining a low rate would indeed increase attractiveness of DOPs for developers, however, might also bear risks for the achievement of the governments short-term climate policy objectives. Thus, alike at option 2 a risk analysis should be conducted, whereby the costs of risk bearing (CORB)²⁵⁹ should be compensated by the market value of GHG-abatements wherefore no ERUs are issued. In contrast to option 2, however, no dead weight loss (DWL) is caused as the level of achieved GHG-abatements is not reduced.

Conclusion: This DOP-scheme option compensates the government for potential risks by passing over a certain fraction of GHG-abatements to be assigned to governmental efforts for achieving its climate protection targets. The discount rate for issued ERUs has to be balanced in a way that both the government as well as private project developers benefits from accomplishing DOPs. This DOP-scheme option might be appropriate in cases where existing pollution control instruments do not induce GHG-abatements in certain sectors to a satisfactory extent, i.e. where the informational advantage of the “search engine market” might be necessary to raise further GHG-abatements.

²⁵⁹ Compare Perman et al. (2003); p. 447

9.4 OPTION 4: DOP-SCHEME WITH THE GOVERNMENT AS INVESTOR

This design option of DOP-schemes also uses the strength of the “search engine” market: best knowledge about cheap abatement possibilities. This implies that for this design option, private project developers also represent an essential pillar. However, in contrary to the aforementioned options of DOP-schemes, the government – and not private investors – is the owner of thereby generated carbon offset credits.

Figure 32 Schematic illustration of a DOP-scheme where the government acts as an investor

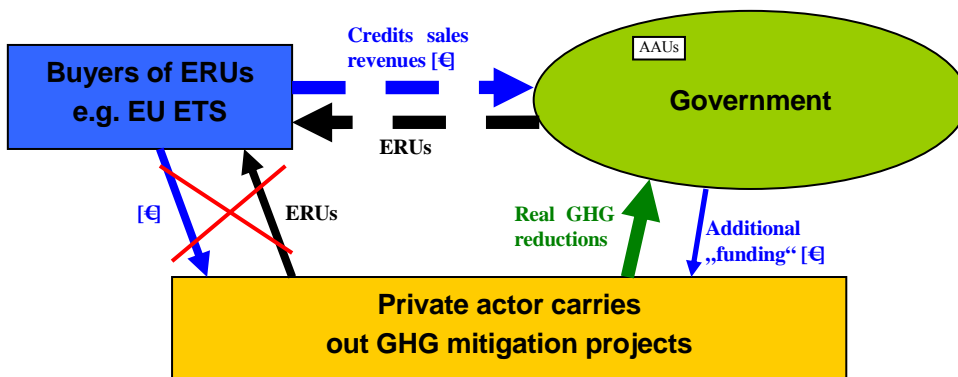

Source: own illustration

Certain subsidies might not be sufficient for GHG mitigation measures to be carried out. Additional money would be necessary – money which could be provided by the carbon market as discussed at DOP-options before. However, this “money gap” could also be – temporarily – provided by the government, as depicted in Figure 32. This also implies that the government temporarily takes the role of the emissions market by providing additional funding for projects. Economically rational private project developers could express their demand for additional funding to cover costs. By granting these additional funds, GHG-abatement measures could be accomplished by private actors. As these investments would not take place in the absence of this additional funding, the measures would be additional to BAU. Applying the JI certification procedure, carbon offset credits (in this case, ERUs) could be generated. As the government provides these additional financial funds next to general subsidies, it becomes the owner of generated credits (although private actors accomplish abatement measures). No connection exists between private actors – basically the implementers of GHG-abatement measures – and the carbon credits market.

A crucial question is how much of additional funding should be provided by the government. The government might be interested to stimulate as many additional GHG-abatements as possible with additionally granted funds. Therefore, a competitive environment between project developers should be established in order to ensure that they would not overstate the amount of required funds. Similar to design option 1²⁶⁰, this could be established via a tender

²⁶⁰ DOP-scheme based on the voluntary carbon offset market including a tender for projects

for low-cost, i.e., CO₂-efficient, project proposals.²⁶¹ Private project developers could state their demand for additional funding necessary for the implementation of envisaged projects. Submitted proposals could then be ranked according to their CO₂-efficiency. Due to a limited budget available, only those projects that offer the highest CO₂-efficiency would be considered for additional funding.

Such granting of additional funds might lead to the conclusion that this is simply a more intensive drawing on grantable funds from existing subsidy schemes. However, the difference is the freedom of future usage of generated credits, as illustrated in the figure below:

Figure 33 Schematic illustration of money flows in the DOP-scheme with the government as investor

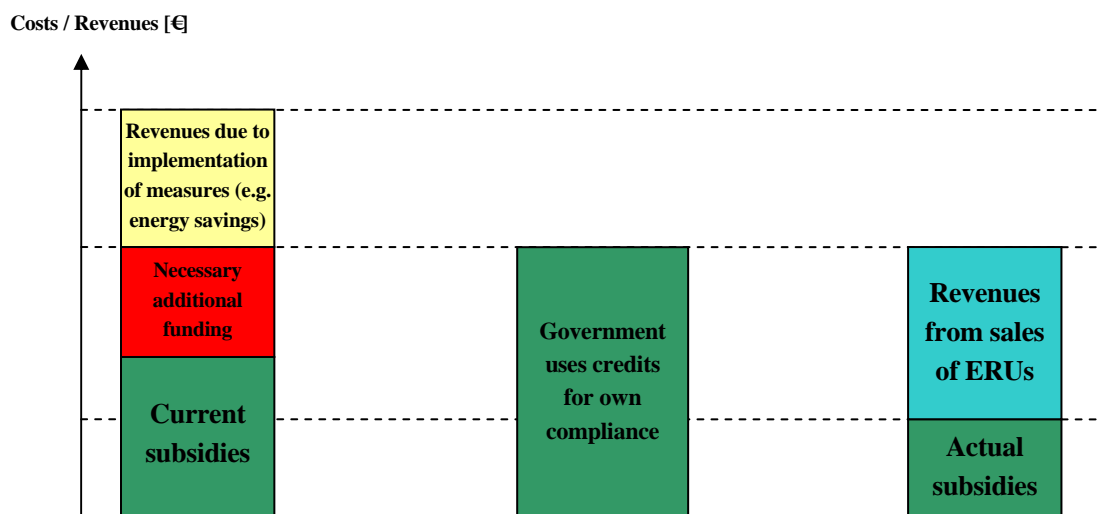

Source: own illustration

The left bar in Figure 33 shows the costs for accomplishing GHG-abatement measures. Project developers would accomplish GHG-abatement measures if these costs are either covered by future cost savings due to higher energy efficiency, by general subsidies and by mentioned additional funding. As the government would own generated credits, the government could decide over their future usage:

On the one hand, the government could keep these generated credits to use them for its own compliance. This option would truly be similar to a simple increase in granted subsidies²⁶², as shown in the central bar of Figure 33.

On the other hand, the government has no complete information about whether it will achieve its climate protection targets in the future, i.e., whether the targets will be over-fulfilled or not reached. Therefore this instrument might be convenient to provide the highest possible

²⁶¹ Experiences with this procedure could already be collected e.g. by the “Auction Programme” of the Swiss “Climate Cent Foundation”, <http://klimarappen.ch/en/programmes/project-funding-programmes.html>, December 11, 2009. The program’s procedure is provided at <http://klimarappen.ch/fileadmin/Downloads/Ablauf.pdf>, December 11, 2009.

flexibility. If forecasts show that a certain target can hardly be achieved, the government could hoard generated credits. On the contrary, the projections could show that the government's strategy to achieve its climate protection targets seems successful²⁶³ and the targets could possibly be over-fulfilled. In that case, the government could sell generated credits, using the arbitrage between AAUs and ERUs²⁶⁴. This would lower the overall subsidy rate for respective GHG-abatements compared to situations without DOPs. Furthermore, even if ERUs were sold, the government would benefit from achieved GHG-abatements in subsequent compliance periods.

Conclusion: This option is the first DOP-scheme design where the government temporarily plays the role of the carbon offset market – namely providing required financial assistance for GHG-abatement projects. Therefore, this DOP-scheme design option has the unique feature that not private project developers but the government owns generated credits. This instrument might be not appropriate if credits were only generated to be used for governmental compliance. Other pollution control instruments such as subsidies²⁶⁵ may be able to also achieve this target by even lower costs, as no efforts for e.g. MRV have to be made. However, this design option provides high flexibility for response to changing circumstances, e.g. at over-fulfilling of climate protection targets instead of a precision landing. In the case of an over-fulfillment of climate protection targets generated credits could be sold and structural change towards more climate protection could be achieved possibly cheaper than via conventional subsidy schemes.

9.5 COMPARISON OF DIFFERENT OPTIONS OF DOP-SCHEMES

In the following subsections, the discussed design options of DOP-schemes will be compared in order to point out their pros and cons. This comparison is based on the same evaluating criteria as used in section 7.3, namely cost efficiency of DOPs, their need for public funds, flexibility of this instrument, the need for the government to possess certain information, competition for cheap abatement options and support of this instrument to achieve governmental climate protection targets²⁶⁶.

9.5.1 Cost efficiency

All discussed design options of DOP-schemes are economic incentive-based instruments. Thus, induced GHG-reductions of DOPs could be achieved at lower costs than through command & control (C&C) instruments.²⁶⁷

²⁶² At this point the question arises whether used public funds should better be taken for stimulating GHG-mitigation measures at lower total subsidy costs.

²⁶³ Also possibly accompanied by other exogenous circumstances as for instance increased prizes for fossil fuels

²⁶⁴ Arbitrage is generated by upgrading relatively low-price AAUs to relatively high-price ERUs.

²⁶⁵ E.g. the Austrian environmental support scheme (Umweltfoerderung im Inland – UFI)

²⁶⁶ Find a detailed explanation of these criteria in chapter 7.3

²⁶⁷ However, due to certain non-financial barriers economic incentive-based instruments might not induce intended GHG-abatements. This could – in the long run – also be not economically efficient.

However, the design options of DOP-schemes considerably differ with respect to their targeted GHG-mitigation portfolio. The DOP-scheme based on the voluntary carbon offset market without involving the government²⁶⁸, the DOP-scheme option 2²⁶⁹ and the DOP-scheme option 3²⁷⁰ are designed in a way that only those GHG-mitigation opportunities are considered which can be implemented at the lowest costs.

By contrast, the DOP-scheme based on the voluntary carbon offset market including governmental contributions²⁷¹ and the DOP-scheme option 4²⁷² are designed in a different way. As governmental funds are (also) used the government could prioritize certain project-types whose implementation could achieve also other policy targets. These options therefore stipulate that not necessarily the overall cheapest GHG-mitigation opportunities are raised, but rather only the cheapest GHG-mitigation opportunities of project-types which are prioritized by the government. This means that these design options of DOP-schemes would not cover the most (CO₂-)cost efficient potential available within the economy, but rather raise the cheapest GHG-abatement opportunities within a portfolio of possibly non-(CO₂-)cost efficient opportunities. However, even if these design options could not be named as (CO₂-)cost efficient (though they are economic incentive-based instruments), GHG-abatements evolved by these DOP-design options might be still highly desirable from a less narrowed point of view: Due to the fact that the government tries to achieve also other policy targets when co-financing these GHG-abatement measures, the spent money would potentially “kill two birds (CO₂-reduction, other targets) with one stone”. This makes those design options possibly more cost-efficient than the before named “cost-efficient ones” as they enable to evolve cost-efficient projects from the overall point of view.

Conclusion: The DOP-scheme design option based on the voluntary carbon offset market without involving the government as well as option 2 and option 3 would be lead to GHG-abatements most cost efficiently. The DOP-scheme based on the voluntary carbon offset market including governmental contributions as well as option 4 would only lead to a cost efficient selection of GHG-abatements from a portfolio of not necessarily cheapest abatement opportunities. However, this view could change if the achievement of other policy goals – which are explicitly pursued at non-CO₂-efficient design options – is also taken into consideration.

9.5.2 Need for public funds

In principle, it is possible that DOP-developers where allowed to also apply for existing, governmental subsidies to finance their projects²⁷³, always taking into account strict additionality requirements. This leads to costs for the government. Moreover, the government might face costs of administrating these DOP-schemes and of enforcing legal requirements for them.

²⁶⁸ DOP-scheme design option 1 without governmental contributions, also described in chapter 7.1

²⁶⁹ DOP-scheme based on Domestic JI with transfer of economic benefits

²⁷⁰ DOP-scheme based on Domestic JI with discounting

²⁷¹ Chapter 9.1

²⁷² DOP-scheme with the government as investor

²⁷³ This option could also be excluded by the government. However, this might be considerably affect the attractiveness and therefore the potential of DOPs

Apart from that, the DOP-scheme based on the voluntary carbon market without governmental contributions as well as option 2²⁷⁴ and option 3²⁷⁵ would not impose further costs on the government.

However, the DOP-scheme based on the voluntary carbon offset market with governmental contributions as well as option 4²⁷⁶ are quite different in this respect. These options of DOP-scheme designs would need additional public funds, as the government is asked to provide additional²⁷⁷ financial assistance.

Conclusion: All design options of DOP-schemes would impose costs for administration and enforcement. Also, all options would require access to governmental subsidy schemes as this might considerably impact the GHG-abatement potential of DOPs. However, analyzed design options considerably differ in their need for additional public funds.

9.5.3 Flexibility

As already mentioned, successful implementation of DOPs needs rather long time horizons: Project developers need to be assured that implemented DOPs could generate sellable carbon offset credits within a certain and agreed period of time. This confidence is necessary for all discussed design options of DOP-schemes; therefore the legal frameworks for DOP-schemes should not be changed frequently and abruptly. However, the government might be flexible in nominating further project-types eligible for DOPs.

Conclusion: From the viewpoint of flexibility all analyzed DOP-scheme designs are similar.

9.5.4 Need for the government to possess certain information

In principle, the necessity for the government to possess much information is rather minor as the “search engine” market is looking for additional GHG-mitigation potential that would then be raised by private actors. If a design option includes the possibility for additional governmental funding via a call for tenders²⁷⁸, competition among project applicants would ensure that the government receives correct information about requested additional financial assistance.

However, in order to protect against possible risks of DOPs, the government would need to possess information, whose generation might be tricky. In particular, when deciding about siphoning off a share of projects implementers’ profits²⁷⁹ or discounting issued ERUs²⁸⁰, the government would need information to determine the cost of risk bearing (CORB) mentioned earlier.

²⁷⁴ DOP-scheme based on Domestic JI with transfer of economic benefits

²⁷⁵ DOP-scheme based on Domestic JI with discounting

²⁷⁶ DOP-scheme with the government as investor

²⁷⁷ “Additional” is meant in respect to funding additional to existing governmental subsidies and to revenues from credits-sales

²⁷⁸ DOP-scheme based on the voluntary carbon offset market with governmental contributions, as well as DOP-scheme with government as investor

²⁷⁹ At the DOP-scheme based on Domestic JI with transfer of economic benefits

²⁸⁰ At the DOP-scheme based on Domestic JI with discounting

Conclusion: All various options of DOP-schemes are designed in a way that information about cheap GHG-abatement opportunities is provided by the “search engine” market. However, the government might be required to possess information which enables the government to fix appropriate rates for siphoning off revenues of investors or discounting the amounts of issued ERUs.

9.5.5 Competition for cheap abatement options

All discussed DOP-scheme options do not lead to a competition for cheap abatement options, as DOPs would, by definition, raise only this potential which would not have been raised by existing pollution control instruments. This means that DOPs would only support those GHG-abatements that no existing instruments focus on yet or where existing instruments provide inadequate incentives.

As elaborated already intensively in chapter 7.3.5 DOPs based on JI could lead to competition for cheap abatement options. In contrast to that, DOP-schemes based on the Voluntary Carbon Offset Market do not face this problem.

However, in the case of DOP-schemes based on JI this is only true if the scope of governmental climate policy – i.e. the incentives of existing pollution control instruments – will not be extended considerably in the future. Otherwise, GHG-abatements by DOPs – initially achieved additionally – could be achieved in the future also by extending of existing pollution control instruments. In other words, DOPs based on JI might raise exactly that potential which might be raised also by governmental actions in the future. However, the scope of expansion is not predictable, i.e. competition for cheap abatement options might, but need not necessarily evolve due to DOPs.

Conclusion: DOP-schemes do not cause competition for cheap abatement opportunities, as only this potential of GHG-reductions is raised by DOPs, which would not be raised otherwise. However, existing pollution control policies might develop and their incentives might improve. Therefore, competition between DOPs based on JI and existing pollution control policies might evolve in the future.

9.5.6 Support to achieve governmental climate protection targets

DOP-schemes designed to generate Voluntary Offset Credits (VOCs) assist the government’s efforts to achieve its climate protection targets, as mentioned above. They lead to GHG-abatements without causing transfers of AAUs away from the government’s budget. Moreover, this type of DOP-schemes is appropriate to generate better knowledge about GHG-abatement potential and its costs in non-ETS-areas.

A more detailed analysis is needed for DOP-schemes based on Domestic JI. Regarding governmental climate protection efforts, this type of DOP-schemes implies a zero-sum game for the government: By raising a potential that would not be raised by existing instruments, real GHG-emissions decrease. Consequently, available AAUs of the government’s AAU-budget decrease by the same amount, as generated ERUs have to be backed-up by a corresponding amount of AAUs. In order to benefit from DOPs, the government would need

to introduce certain provisions as siphoning off parts of the projects developers' profits or discounting the amount of assigned ERUs. However, the government has to choose an appropriate rate for siphoning off or discounting. A rate too low might not only bring very few benefits from DOPs to the government, but would also get rather low protection against certain non-additionality of projects that cannot be filtered out even by strict additionality tests. Therefore, the contribution of DOP-schemes based on Domestic JI to achieving the government's climate protection targets also depends on the choice of this siphoning off or discounting rate.

Generally, for achieving short-term GHG-abatement targets, limited funds should be used only for the most CO₂-efficient abatements.²⁸¹ However, this is neither the case at option 1²⁸² with governmental contribution, nor at option 4²⁸³ if generated credits were used for government's compliance. Thus, not all DOP-schemes help to reach governmental compliance at lowest possible costs. However, also existing pollution control instruments as subsidies do not select only the low-costs abatement potential.²⁸⁴

Conclusion: If all necessary provisions were applied appropriately²⁸⁵, DOP-schemes generally assist to achieve the government's climate protection targets. However, some design options might be in need of public money.

9.6 CONCLUSION

In the analysis of this chapter different design options have been discussed for both categories of DOP-schemes²⁸⁶ in order to provide a value added for the Austrian climate policy.

It turns out that option 1²⁸⁷ is highly beneficial for achieving the government's climate protection target. It does not cause any competition for cheap GHG-abatement opportunities and leads to GHG-abatements without causing AAU-transfers. To contribute substantially to Austria's climate targets, demand for this sort of generated credits has to be increased significantly. This might not be possible in the short-run. Therefore this category of DOP-schemes might not highly contribute to achieve the oncoming Kyoto-target. However, this instrument might be appropriate to gather more information about barriers for implementation of GHG-abatements which might also be necessary to improve existing pollution control instruments.

²⁸¹ However, from a long-run perspective also co-effects of GHG-mitigation measures should be taken into consideration. Compare Pretenthaler, Steiner, Schlamadinger (2006).

²⁸² DOP-scheme based on the voluntary carbon offset market

²⁸³ DOP-scheme based on Domestic JI with government as investor

²⁸⁴ This is wise from a long-term perspective. From that viewpoint, project's selection should not only be based on CO₂-efficiency but also on generated co-benefits. (See Pretenthaler, Steiner, Schlamadinger (2006))

²⁸⁵ This means for instance, whether additionality test are really strict additional or rates for siphoning off profits are high enough to compensate the government for risks.

²⁸⁶ DOP-schemes based on the voluntary carbon offset market; DOP-schemes based on Domestic JI

²⁸⁷ DOP-scheme based on the voluntary carbon offset market.

No lack of demand might be faced for credits generated by DOPs based on Domestic JI. However, DOPs based on JI might not be that beneficial for the government's compliance than DOPs based on the voluntary carbon offset market. Anyway, the government could include provisions to also benefit from DOPs. To set these provisions appropriately certain information is necessary – information, which might not be easy to gather. In the short-term – i.e. for achieving the Kyoto-target – none of the DOP-schemes based on Domestic JI would be able to contribute to governmental compliance, as the remaining period until 2012 would be too narrow. Subsequent compliance periods, however, might be long enough to enable the generation of a substantial amount of offset credits. This would be highly beneficial for the government in the long-run as achieved GHG-abatements could be assigned to governmental efforts for compliance periods subsequent to the period where GHG-abatements were achieved.

10 Economic analysis of Domestic Offset Projects

Governments as well as companies covered by emission trading schemes (ETSs) could achieve their climate protection targets either by own actions or by purchasing offset credits. This analysis shows economic effects – with special focus on effects on consumer welfare – of certain (among many) alternatives for achieving their specific GHG-emission targets.

This chapter starts with an explanation of analyzed alternatives (case studies). It is followed by a discussion of tentative effects – and their directions – from described case studies. After that a model description is carried out, including an explanation of various possibilities for calculating economic effects, as well as a detailed explanation of the modeling approach, its implementation and the used algorithm. This is followed by describing the underlying database. Based on that, economic effects of considered case studies will be computed and explained. Monetized domestic co-effects are included into the economic analysis. To ensure robustness of results, a sensitivity analysis finalizes the economic analysis.

10.1 CASE STUDIES

To achieve their climate protection targets, governments and companies covered by an ETS face many different alternatives. Exemplarily in this analysis, three combinations of alternatives for governments and companies will be compared in subsequent sub-chapters. In this sub-chapter, therefore, the different analyzed case studies will be explained shortly.

One possibility for achieving climate protection targets – both for governments as well as companies – is to simply purchase carbon offset credits abroad. This possibility will be considered as case study 1. Thereby, an iron and steel producing installation representing companies covered by the EU-ETS as well as the government purchase emission reductions (= carbon offset credits) eligible for compliance. Prices for these credits are determined exogenously at the global market and may be highly volatile. Exemplarily it is assumed that the price per credit (equates one metric ton of CO₂) is fixed at €10.²⁸⁸ Furthermore it is exemplarily assumed for all case studies that the installation demands credits equivalent to 80,000 tons of GHG emission reductions whereas the government needs credits for 20,000 tons. The purchase of the installation will be financed by the installation itself, thereby making its goods more expensive. The purchase of the government will be financed by revenues from an endogenously determined tax especially introduced for this reason, i.e. this purchase is not financed by increasing public debts.

Case study 2 is a mixture of purchasing credits abroad and intensifying national GHG-abatement actions. The representative installation still purchases credits abroad equivalent to 80,000 tons of emission reductions. The price per purchased credit is still assumed to be

²⁸⁸ The average price of so far purchased ERUs and CERs within the portfolio of the Austrian JI/CDM program is € 8.69 (without immaterial support); Kommunalkredit Public Consulting [1] (2008), p. 18

€ 10.- . Costs will still be covered by the installation itself by making its goods more expensive for consumers. The government, however, does not purchase credits abroad, but rather intensifies own actions. Exemplarily among many possible opportunities, it increases funds available for promoting natural gas passenger cars by an extent that GHG-emission reductions of 20,000 tons additionally are induced.²⁸⁹ These domestic GHG-emission reductions should be achieved within an assumed compliance period of 8 years. It is assumed that all investments are done at the beginning of the compliance period to ensure that the necessary number of involved vehicles is as low as possible.²⁹⁰ For illustrative reasons the government applies for that the Austrian environmental support scheme on the operational level²⁹¹ by increasing available funds. In the past, subsidy rates of this support scheme have been quite different.²⁹² For subsequent calculations an average of 19 % is supposed. Necessary funds are generated by equally imposing an ad-valorem tax²⁹³ on final demand.

As a slight variation of these assumptions, case study 2+ is introduced. It assumes in contrast to case study 2 that the government could attract individuals who are willing to switch from conventional powered passenger cars to natural gas powered cars more easily. It is assumed at this stage that the government provides a funding rate (slightly more than 1%) which is only slightly higher than the funding rate assumed to be provided by a DOP-developer in the subsequent case study 3. Certainly, this assumption contrasts the statement above that the ability to find low cost GHG-abatement potential is rather attributed to the “search engine market” rather than to the government. Thus, it is clearly stated that this variation of simulation does not base on the assumption that the “searching power” of the government is equal to the searching power of the market. This simulation is rather accomplished to find out to which extent the choice of the subsidy rate affects the consumer welfare.

In case study 3 GHG-emission reductions are generated by DOPs. The aforementioned representative installation searches for domestic GHG-abatement possibilities outside its capped facilities, comprising a potential for GHG-reductions of 100,000 tons.²⁹⁴ For comparability it is assumed that the same project-type – fuel switch from diesel and gasoline powered cars to natural gas powered cars – is chosen like in case study 2. It is also assumed that the representative installation knows about cheap GHG-abatement opportunities (keyword “search engine market”) and is also able to raise this potential. Using this informational advantage the representative installation implements a Domestic Offset Project by taking actions to initiate relevant and additional GHG-abatements – inter alia by providing necessary “start-up financing”. The DOP-scheme includes the provision of discounting issued ERUs.²⁹⁵ This implies that the government gets compensated for the potential problems associated with this DOP-scheme option, namely potential non-additionality²⁹⁶ and

²⁸⁹ See detailed calculations in Annex V

²⁹⁰ See also Annex V

²⁹¹ Umweltfoerderung im Inland

²⁹² Subsidy rates of the focal point of support “transport measures at the operational level” are used for subsequent calculations. Subsidy rates of this focal point have been 19 % in the subsidy period 2002-2004 and 27.3 % in the subsidy period 2005-2007 (Kamer, Kletzan, Kraner, Harather [2] (2008), p. 104)

²⁹³ The tax rate is endogenously determined

²⁹⁴ This amount of GHG-abatements is always calculated as GHG-reductions within a certain period of time.

²⁹⁵ See for explanation chapter 9.3

²⁹⁶ See chapter 5.2.1

competition for cheap abatement measures²⁹⁷. This discount rate is supposed to be 20 %, leading that the government gets 20,000 credits for its own compliance usage. The remaining 80,000 credits can be used by the representative installation for its compliance use or to resell them at the emission trading market. The representative installation might be willing to implement a DOP as long as generating 100,000 credits domestically is less costly than purchasing 80,000 credits abroad, which results in a funding rate slightly less than 1 %. Once again it is assumed that all investments are done at the beginning of the compliance period to ensure that the necessary number of involved vehicles is as low as possible.²⁹⁸

10.2 ANTICIPATED EFFECTS OF ANALYZED MEASURES TO COMPLY WITH CLIMATE PROTECTION TARGETS

Actions to achieve a certain climate protection target always cause a certain economic effect. This overall economic effect can be splitted into various “sub-effects”.²⁹⁹ Therefore, this subchapter will include a short description of these sub-effects. Furthermore, tentative statements of expected directions of these sub-effects for each considered case study will be provided. Particularly the domestic implications on GDP, employment and national budget as well as on the consumer welfare will be interesting, whereby the now considered consumer welfare should be stated more precisely as economic consumer welfare. The computed economic consumer welfare is based on a Hicksian monetary measure of utility change, the equivalent variation.³⁰⁰ In the same manner, the “government welfare” is computed, which actually affects the consumer and could therefore be seen as part of the consumer welfare. However, a separated depiction is chosen for explicitly showing the welfare effect to the government. As the government welfare is ultimately a part of the consumer welfare, the same welfare function as used for calculating the pure economic consumer welfare is assumed also for the government welfare.

One of considered sub-effects is the so-called investment effect. This effect directly results from accomplishing a certain climate protection investment. Each investment activity leads to production activities for required goods and services as well as to production of inputs necessary for producing required goods and services. The induced increase of economic activities leads to a higher demand for manpower and therefore to an increase in value added. Due to increased tax revenues caused by increased economic activities, and due to less unemployment expenditures caused by an increased demand for labor, the national budget might benefit. The magnitude of these impacts domestically depends on the extent domestic companies and domestic manpower are involved in providing required goods and services. Using the knowledge about these implications, the following tentative statement can be given for analyzed case studies: (1) Purchasing CO₂-certificates from abroad detracts funds from the economy – funds which could have been used for other consumptions or

²⁹⁷ See chapter 5.2.2

²⁹⁸ See also Annex V

²⁹⁹ See also Kletzan, Steininger, Hochwald (2005), pp. 25-27; or Pfaffenberger, Nguyen, Gabriel (2003), pp. 15-19

³⁰⁰ See Perman et al. (2003), chapter 12 for a detailed introduction to the two Hicksian monetary measures of the utility change – compensating variation and equivalent variation

investments. Therefore, this way of achieving a certain amount of GHG-reductions implicates no domestic investment effects. As it also curtails the portfolio of goods and services used by the consumer, this way leads also to a reduction of consumer welfare. (2) Achieving a certain GHG-reduction target by substituting conventional cars by natural gas powered cars is a special case among other domestically accomplished GHG-mitigation measures. It is assumed that purchasing natural gas powered cars is as costly as purchasing conventional cars. Thus, substituting a certain number of conventional cars by the same number of natural gas powered cars does not lead to higher investment costs. Therefore, in this special case no investment effect is induced by this way of achieving GHG-abatements domestically. No effect on consumer welfare is expected due to solely switching cars' power engines.

The second mentioned effect is induced by operating and maintaining assets purchased for climate protection and credits generation purposes. This includes manpower for operating as well as services for maintenance. Naturally, purchasing CO₂-certificates from abroad does not induce such an effect. Substituting conventional cars by natural gas powered cars leads to lower fuel demand. Therefore, this fuel switch induces negative effects in GDP and employment. Due to decreased economic activities, the representative consumer's welfare will decrease as its provided primary inputs labor and capital become less demanded.

Another economic effect is the effect on the budget of households and the government due to changed relative prices caused by GHG abatement measures. The promotion of more fuel efficient natural gas powered cars leads to cheaper passenger mobility. This results in a positive budget effect as more funds are available for other expenditures. However, necessary fund raising for financing subsidies or purchasing CO₂-certificates respectively lead in turn to increased prices for goods. This results again in a negative budget effect as it limits the budget of households and the government and leads to a crowding out of other purchases. The net effect of those two fractions of the budget effect decides the change in economic consumer welfare.

An important economic effect is the so-called dynamic effect. This effect is caused by changes in relative prices which lead to corresponding adjustments in an economy. These changes in relative prices could be initiated for instance by taxes on certain goods or by subsidizing specific technologies.³⁰¹ For instance, subsidizing GHG-abating technologies changes the relative prices of these technologies. This makes those technologies more interesting for individuals. Therefore, in the long run, the structure of energy inputs changes. However, Kletzan, Steininger, Hochwald (2005) state that direct implications of this effect on economic variables are difficult to quantify.³⁰² Anyway, caused by a shift towards green technologies producers might anticipate an evolving future market. Therefore they might be willing to invest into further development of these technologies and drive innovation. This might lead to first-mover advantages and increased exporting possibilities.³⁰³ In all three considered case studies, the dynamic effect will cause economic changes. However, the magnitude of this effect depends on the magnitude of simulated economic shock, which differs in each case study.

³⁰¹ Compare Haas, Kranzl (2002)

³⁰² Kletzan, Steininger, Hochwald (2005), p. 26

³⁰³ See for that also Kletzan, Steininger, Hochwald (2005), p. 26

Closely connected with the dynamic effect is the foreign trade effect. This effect results from an increase or decrease of exports or imports.³⁰⁴ The increases in prices of the representative iron and steel producing installation (for financing its credit purchases) leads to a foreign trade disadvantage for respective, domestically produced goods. Decreasing exports will reduce GDP and subsequently economic consumer welfare, as income from primary input factors will decline as well.

The economic shocks simulated in accomplished case studies cause initial price increases due to varying taxation of goods. However, subsequent effects cause prices of primary inputs (labor, capital) to decline (relative to the numeraire “foreign exchange”) which in sum causes a price decrease of domestically produced goods relative to the numeraire foreign exchange. This results in a foreign trade advantage for domestically produced goods.

Apart from these structural effects of climate protection activities, also effects on production capacities have to be considered. Investing into climate protection measures leads to a change of a country’s capital stock.³⁰⁵ The effect of a change in capital stock is ambivalent: On the one hand climate protection measures may lead to an increase of an economy’s production capacity; this would lead to an increased value added in subsequent periods.³⁰⁶ On the other hand, climate protection measures are not only based on fuel changes, but may also lead to higher energy efficiency, i.e. lower energy demand. This leads to a decrease in value added. In none of the three case studies extensions of the country’s capital stock occur. Domestic measures only lead to a switch from conventional technologies (diesel and gasoline powered engines) to a more innovative technology (natural gas powered engines). Thereby, the more innovative technology leads to lower energy demand.

Essential are also multiplier effects of measures. This kind of effects has to be seen closely related to effects mentioned before rather than an independent kind of effects. All impacts of these effects are reinforcing, thereby multiplying initial impacts if the economy is not already operating at full capacity.

10.3 MODEL DESCRIPTION

In this section the choice of the modeling approach will be explained. Moreover, the chosen modeling approach, its implementation and the used algorithm will be explained.

10.3.1 Chosen modeling approach

For evaluating economic effects due to different policies three different modeling approaches were possible: an econometric approach, an input-output analysis and a computable general equilibrium (CGE) analysis. For simulating environmental and resource economic policies

³⁰⁴ Compare Kletzan, Steininger, Hochwald (2005), p. 27

³⁰⁵ It is assumed here that no crowding out of other investments happens, i.e. that the economy has not reached its production capacity limit.

³⁰⁶ For instance, a conversion from fossil fired heating systems to biomass fired ones may lead to an expansion of domestic production capacities for biomass. This substitutes imported fossil fuels.

mostly the CGE approach is used.³⁰⁷ The strength of the CGE approach is using information about economic connections of different sectors while – in contrary to a pure input-output analysis – also using endogenously modeled input-coefficients.³⁰⁸ “Utility- and profit-maximizing behaviour plays no role in input-output models: there are no demand and supply equations and no capacity constraints. Concern with the rather limited behavioural basis of input-output models has led to a growing interest in applied, or computable, general equilibrium models.”³⁰⁹ An additional strength is the closeness character of the approach: All increased investments have to be financed either by increasing debts or by reducing other investments, and all saved funds from decreasing investments have to be used elsewhere. This, in turn, leads also to economic effects, which can be included in the evaluation. Thereby, also subsequent macroeconomic impacts of a changed national budget can be computed endogenously. One possible weakness of the CGE approach is the high dependency of results from the choice of the so-called elasticities of substitution.³¹⁰ These elasticities show the extents of reaction on factor input ratios caused by price changes for these input factors.

The subsequent economic evaluation builds up on models used by Kletzan, Steininger, Hochwald (2005) and the adapted model of Pretenthaler, Dalla-Via, et al. (2007)³¹¹. It uses an input-output-table (IOT) for including information about sectoral interactions. This is the base for the CGE model. Within the CGE model production functions of enterprises can be flexibly configured, as well as – as mentioned already – the financing structure is closed.

This modeling approach allows to quantify effects on value added (aggregated as well as on sectoral level), on employment (aggregated as well as on sectoral level), on gross production values of different sectors as well as on the national budget (separated into income for the national budget as well as expenditures). Furthermore, effects of different options to achieve GHG-reductions on economic consumer welfare are computed. Leaving now welfare impacts due to avoided external effects out of the scope (environmental based consumer welfare), pure economic consumer welfare is represented – as mentioned already – by the amount of goods available for the representative household’s consumption without impoverishing it.³¹² In other words, this is the amount of goods which can be afforded from yields generated by providing the household’s input factors labor and capital as well as from tax transfers while simultaneously taking into account changing relative prices for goods.

10.3.2 Description of the modeling approach³¹³

The used modeling approach is based on the idea that the economy, i.e. its markets, are in equilibrium at the beginning. Via economic shocks, i.e. policy simulations, a new equilibrium is reached. By comparing these two states of nature the impacts of policy simulations can be

³⁰⁷ See also Kletzan, Steininger, Hochwald (2005), 35; or Pretenthaler, Dalla-Via, et al (2007), p. 182; or Perman et al. (2003), p. 281.

³⁰⁸ Input coefficients tell about how much intermediary inputs from each sector are necessary for the production of one unit in a specific sector. For detailed explanation of input coefficients see Perman et al. (2003), p. 272 et seqq.

³⁰⁹ Perman et al. (2003), p. 281

³¹⁰ See also Kletzan, Steininger, Hochwald (2005).

³¹¹ Styrian Economic Policy Model (SEPM)

³¹² See also Hicks (1946), p. 172

³¹³ The modeling approach is based on that one used in Kletzan, Steininger, Hochwald (2005)

deduced.³¹⁴ In other words, starting from a certain price-vector for all goods and input factors as well as corresponding amounts of production, consumption and needs for primary input factors, applying the model shows changes in the price-vector as well as changes in the level of production, consumption and needs for primary input factors³¹⁵. The model includes the complex relationships of and within markets in the economy. It is based on the neoclassic theory where complete clearance of markets is assumed in principle³¹⁶, taking into account also feedback-effects of economic shocks. The actions of consumers are limited by corresponding budget constraints. Furthermore, all market players are characterized by certain behaviours, e.g. consumers try to maximize their utility. In the following, single elements and players of the model are described in detail.

Production

The modeling of the economy's production is based on the classification used in Kletzan, Steininger, Hochwald (2005) who disaggregated the economy's production into 35 production sectors. This classification is based on the Austrian Climate Policy Investment (ACPI) model. For simulation purposes one additional sector "MOBIL" was introduced. The output of this sector can be achieved by two different ways, in each case using partly different technologies. The different technologies are either conventionally powered passenger cars or natural gas powered cars.

³¹⁴ This shows a comparative-static model where the reactions of the economy are modeled at one point in time only

³¹⁵ See also Kletzan, Steininger, Hochwald (2005) / or Pretenthaler et al. (2007)

³¹⁶ However, this does not need to be always the case in the model

Table 16 Sectoral classification

	Acronym	Sectors	Classification according to ÖNACE
1	LAWI	Agriculture, Forestry and Fishery	1, 2, 5
2	KOHLE	Mining of coal and lignite	10
3	OELBB	Extraction of crude petroleum and natural gas	11
4	OELVER	Coke, refined petroleum products	23
5	ELEK	Electricity, gas, steam and hot water supply	40
6	WASSER	Collection, purification and distribution of water	41
7	EISEN	Basic metals	27
8	STEIN	Mining of metal ores; Other mining and quarrying; Other non-metallic mineral products	13, 14, 26
9	CHEMIE	Chemicals and chemical products	24
10	METALL	Fabricated metal products, except machinery and equipment	28
11	MASCH	Machinery and equipment n.e.c.	29
12	BUEROM	Office machinery and computers	30
13	ELEINR	Electrical machinery and radio, television and communication equipment and apparatus	31, 32
14	FAHRZ	Motor vehicles, trailers, semi-trailers and other transport equipment	34, 35
15	NAHR	Food products and beverages; Tobacco products	15, 16
16	TEXTIL	Textiles; Wearing apparel; dressing; dyeing of fur; Tanning, dressing of leather; manufacture of luggage	17, 18, 19
17	HOLZ	Wood and products of wood and cork, except furniture	20
18	PAPIER	Pulp, paper and paper products	21
19	VERLAG	Publishing, printing, reproduction of recorded media	22
20	GUMMI	Rubber and plastic products	25
21	RECYC	Recycling	37
22	SPROD	Medical, precision and optical instruments, watches and clocks, furniture	33, 36
23	BAU	Construction	45
24	HANDEL	Wholesale trade, retail trade and commission trade; maintenance and repair of motor vehicles; repair of personal and household goods	50, 51, 52
25	GAST	Hotels and restaurants	55
26	VERK	Land transport excluding passenger cars; transport via pipelines	60 excl. 6022
27	SUL	Water transport, Air transport	61, 62
28	SVERK	Supporting and auxiliary transport activities; activities of travel agencies	63
29	KOMM	Post and telecommunications	64
30	GELD	Financial intermediation, Insurance and pension funding, Activities auxiliary to financial intermediation	65, 66, 67
31	REAL	Real estate activities; Renting of machinery and equipment without operator and of personal and household goods	70, 71
32	DATEN	Computer and related activities	72
33	FUE	Research and development, Other business activities	73, 74
34	SODIEN	Recreational, cultural and sporting activities; Other service activities; Activities of households as employers of domestic staff	92, 93, 95
35	NMDIEN	Public administration and defence; Compulsory social security; Education; Health and social work; Sewage and refuse disposal, sanitation and similar activities	75, 80, 85, 90, 91
36	MOBIL	Land transport by passenger cars	6022 & pro rata 23, 34, 50, 66, 71 of final demand

Source: Aggregated classification based on Austrian Climate Policy Investment (ACPI) model³¹⁷

Domestic output is produced on the one hand by intermediate goods and on the other hand by the aggregate of the primary factors capital and labor. This production is characterized by a Leontief production function. The Leontief production function represents a special case of the constant elasticity of substitution (CES) production function, where the elasticity of substitution equals zero. This means that there is no substitutability between the mentioned

³¹⁷ Compare Kletzan, Steininger, Hochwald (2005), p. 38

inputs (intermediate goods; aggregate of primary factors), so the mentioned inputs of production will be used in fixed proportions (inputs are perfect complements). The corresponding Leontief production function is described by³¹⁸

$$X_j = \min (H_j / A_j , X_{ij} / a_{ij}) \quad \text{for all sectors } j = 1, \dots, 36 \quad (1)$$

where

X_j ... output of domestic production of the sector j

H_j ... available aggregate of the primary factors capital and labor (explained below)

X_{ij} ... available intermediate good i for producing good j

A_j, a_{ij} ... Leontief-input-output coefficients in the sector j

The aggregated input factor of capital and labor itself is divided into the primary inputs capital on the one hand and labor on the other hand. This is shown by the lower nest in the figure below. Therefore, the considered CES production function for goods can be specified as a nested CES production function.

Figure 34 Schematic illustration of the nested CES production function

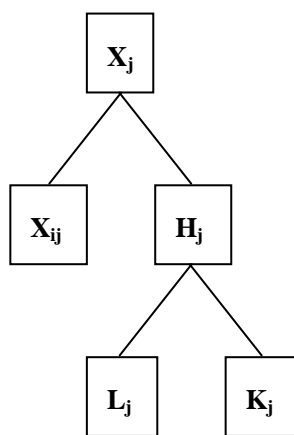

Source: own illustration

The production of the aggregated input factor from capital and labor can be presented as the CES production function

$$H_j = [\delta_j K_j^{(\sigma_j-1)/\sigma_j} + (1-\delta_j) L_j^{(\sigma_j-1)/\sigma_j}]^{\sigma_j/(\sigma_j-1)} \quad \text{for all sectors } j = 1, \dots, 36 \quad (2)$$

³¹⁸ The notation of variables refers to the notation used in Kletzan, Steininger, Hochwald (2005)

where

δ_j ... CES share parameter for the factors capital and labor in sector j

σ_j ... elasticity of substitution between the factors capital and labor in sector j

K_j ... input of capital in sector j

L_j ... input of labor in sector j

Elasticities of substitution between the primary input factors labor and capital vary dramatically in the relevant literature, depending on the method where they have been estimated.³¹⁹ According to Kletzan, Steininger, Hochwald (2005) – thereby referring to Bergmann (2001)³²⁰ – elasticities of substitution between labour and capital are usually fixed between 0 and 1.2³²¹. The magnitude of the elasticity of substitution tells about how flexible companies could change their mix for production inputs as new conditions for production arise. A high elasticity of substitution shows a high flexibility for changing the mix. On the other side, at a low elasticity of substitution, companies cannot react flexible to changed conditions.³²² Therefore the effects of changed conditions will be more substantial with less flexibility for changing the mix. In order to get the highest expectable effects of policy simulations it is therefore necessary to assume an elasticity of substitution between labor and capital of zero.³²³

Labor market

The market for labor is not cleared completely at the beginning. This anomaly to the neoclassical theory is depicted by means of rigid minimum wages. In the applied model, nominal wages increase only according to increases of the consumer price index, however, this does not affect the level of real wages.

Varying demand for labor leads to varying income from this primary input factor for the representative consumer. This affects the consumer's welfare.

Foreign trade

To define demands for domestically produced goods and imported goods of the same category, the so-called Armington assumption of nationally differentiated products has been widely adopted in global computable general equilibrium models.³²⁴ Domestically and foreign produced goods assigned to the same sector classification are imperfect but close substitutes, i.e. they are not completely the same. The amounts of imported and exported goods depend on the comparative prices and the extent of how flexible they could be substituted respectively. These substitution flexibilities for specific goods are expressed by

³¹⁹ Compare Jomini et al. (1994), p. 67

³²⁰ Bergmann, L. (1991): General Equilibrium Effects of Environmental Policy, A CGE-Modelling Approach; in *Environmental and Resource Economics*, 1/1991, p. 43-61.

³²¹ Kletzan, Steininger, Hochwald (2005), p. 38

³²² *Ibid.*, 39

³²³ This choice of elasticity of substitution for primary inputs follows the determination of Kletzan, Steininger, Hochwald (2005)

the Armington-elasticities. The level of exports and imports of each sector j is therefore determined by

$$EX_j = EX_j^0 (P_j^w / P_j)^{\epsilon_j} \text{ and} \tag{3}$$

$$M_j = M_j^0 (P_j / P_j^w)^{\epsilon_j} \tag{4}$$

where

EX_j ... exports of the sector j

M_j imports of the sector j

P_j price for production of the aggregate of goods in sector j

P_j^w world market price for the aggregate of goods in sector j

ϵ_j Armington-elasticity in sector j ³²⁵

Final results of the model might be quite sensitive on the chosen levels of Armington-elasticities. Therefore a careful choice has to be made. The applied model uses Armington-elasticities found by Reinert and Roland-Holst (1992). They have applied an econometric estimation of these elasticities, thereby providing Armington-elasticities for 163 sectors.

The model distinguishes between five different aggregates per category of goods:

Figure 35 Schematic illustration aggregates per category of goods

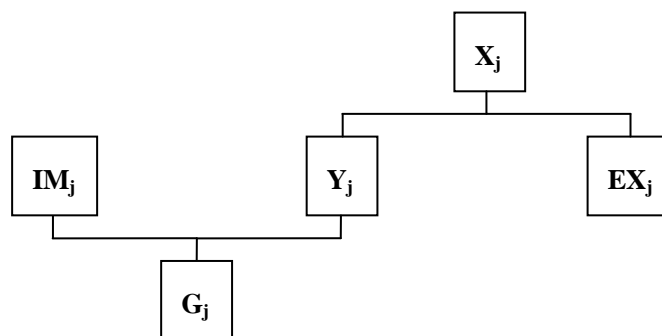

Source: own illustration based on Kletzan, Steininger, Hochwald (2005), and Prettenhaler et al. (2007)

The amount of domestically produced good X_j can be divided into a certain share of domestic usage Y_j and exports EX_j . Imports IM_j combined with Y_j result in the amount of domestically sold good aggregate G_j .

³²⁴ Compare Lloyd and Zhang, p. 3 and Armington (1969)

³²⁵ See Armington (1969), p. 167 et seqq.

In the model the trade balance is assumed to be invariable. Therefore, sectoral changes in demand only lead to structural adjustments of the trade balance without changing the saldo.³²⁶

Demand for goods

A change in the demand for goods is caused on the one hand by a changed demand for intermediary inputs (used by enterprises) and final demand by the representative consumer and the government.

A change in consumer demand is caused – aside from exogenous policy shocks – by changing incomes from its provided primary inputs labor or capital. Prices of those are – in turn – influenced by changing demand.

The government's final demand depends on yields from direct taxes (taxes on labor and capital) as well as indirect taxes (taxes on goods) and its expenses for unemployment benefits and other transfers. Moreover, the model uses public demand for goods as the balancing variable. This means, changing national funds available (e.g. reduced tax incomes and additional unemployment benefits) lead also to a change in governmental demand rather than changing the public debt.

Government

The government's income is comprised by taxation of labor ($lwtaxr \cdot l$) and capital ($ktaxr \cdot k$) as well as from indirect taxes adjusted by sectoral subsidies ($itaxr_j \cdot X_j$). Expenses of the government are unemployment benefits and other transfers as well as governmental consumption of goods and services.

For achieving the government's climate protection target public debt will not be increased. Rather, endogenously determined taxes³²⁷ on domestically produced goods and services will be introduced to provide necessary funds for additional climate protection measures.

10.3.3 Implementation and algorithm

The used model is implemented in the General Algebraic Modeling System (GAMS)³²⁸ and its subsystem Mathematical Programming System for General Equilibrium (MPS/GE)³²⁹.

The used algorithm in this model is the PATH solver.³³⁰ Rutherford (1998) has pointed out the superiority compared to the MILES solver: "... both algorithms are capable of processing very large-dimensional models when they are sparse. PATH is generally more efficient (...)

³²⁶ Compare Kletzan, Steininger, Hochwald (2005), p. 45

³²⁷ Tax rates have been derived endogenously based on exogenously determined tax revenues

³²⁸ See Rosenthal (2008) or McCarl et al. (2008)

³²⁹ Rutherford (1999)

³³⁰ A detailed description of the PATH solver can be found in Dirkse and Ferris (1993)

The comparison between alternative solvers available within GAMS/MCP is not as revealing as a comparison between these solvers ...³³¹

10.4 DATABASE

This section aims at providing a brief overview over the used database and its construction. The main data source for running the model is a social accounting matrix (SAM).³³² “A social accounting matrix represents flows of all economic transactions that take place within an economy.”³³³ “It can be seen a means of presenting in a single matrix the interaction between production, income, consumption and capital accumulation.”³³⁴ Therefore, it “extends the logic of input-output analysis from production to income distribution. This pays attention to the redistribution of factor income to the domestic institutions.”³³⁵

Design of a Social Accounting Matrix (SAM)

In a highly simplified manner, the used social accounting matrix comprises of the following components:

³³¹ Rutherford (1998), p. 134

³³² The values of the data base are referring to the year 2006. It provides the most current data available at the time of respective simulations.

³³³ Compare http://en.wikipedia.org/wiki/Social_accounting_matrix ; August 4, 2010.

³³⁴ Sen (1996); p. 1

³³⁵ Raa (2005); p. 83

Figure 36 Illustration of the applied Social Accounting Matrix (SAM)

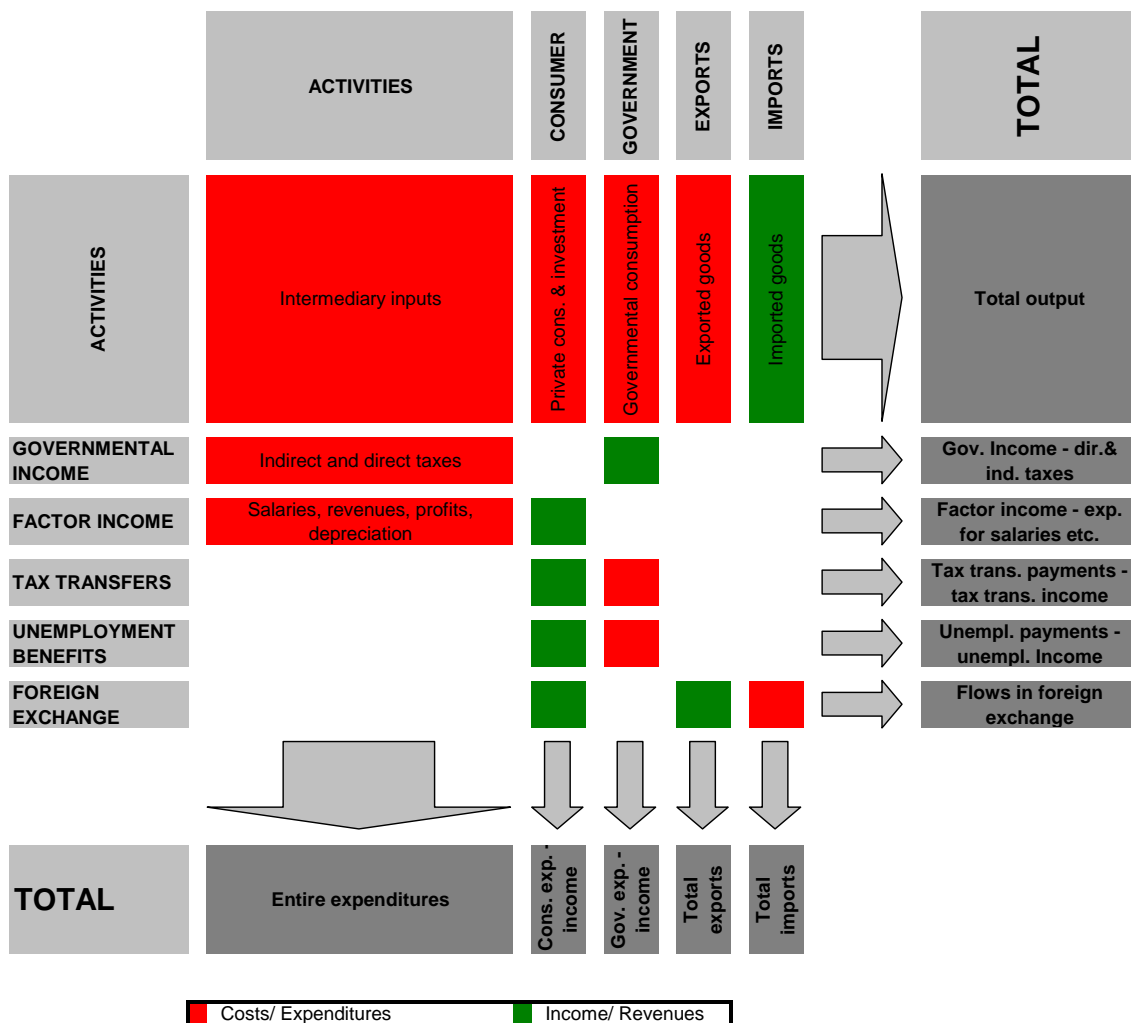

Source: own illustration

The block “*intermediary inputs*” shows the flows of goods and services from activity *i* to activity *j*. Originally based on a 57x57 industry level, this block was aggregated to a 35+1 times 35+1 matrix (see also Table 16). Its compilation is detailed described later on in this section. No distinction is made between domestic and imported components, i.e. it is assumed that imported components produced by a specific activity use the same technology than used for producing this component domestically.

Governmental income comprises revenues from taxes on goods (indirect taxes) as well as taxes on the primary inputs labor and capital (direct taxes). This amount is adjusted by certain public subsidies granted to specific industries (activities). Governmental income is used to finance governmental consumption as well as tax transfers (TXTRNS – governmental transfers except unemployment benefits) and unemployment benefits.

The *factor income* shows the salaries, revenues and profits from providing the primary inputs labor and capital. This amount is adjusted by annual depreciation of capital. The income from

primary inputs is assigned to households (= representative consumer). It partly covers private consumption and investments.

Tax transfers are all governmental benefits excluding unemployment benefits. In the underlying SAM tax transfers are paid by governmental income to partly cover private expenditures.

Unemployment benefits are paid by the government to the representative consumer.

The flows in foreign exchange stem from costs for imports and revenues from exports. The difference in costs and revenues goes to or is paid by the representative consumer respectively.

Additionally – not shown in the simplified depiction of the SAM – information is included about the indirect tax rate and labor employed by each specific activity.

For assembling a social accounting matrix consistent information about economic input-output flows (within a year) is the crucial basis. For that an input-output-table was set up according to the Make-Use framework. This complies with the standards of the “System of National Accounts” (SNA).³³⁶ Used and most current data are provided from the Austrian National Bureau of Statistics.³³⁷

Constructing coefficient matrices

To ensure retraceability of the used database a short description is provided about the assembling method. For leading over from information of asymmetric make- and use matrices to a symmetric input-output matrix several steps are necessary. Firstly, it requires constructing of “coefficient matrices”³³⁸, which are a “matrix of intermediary input coefficients”, a “market-shares matrix” as well as the “product-mix matrix” in certain cases. From those matrices a so-called “technology matrix” can be derived – it is the basis for depicting inter-industry relations suitable for the IO-table.

(1) Matrix of intermediary input coefficients

The matrix of intermediary input coefficients (dimension: goods x activities) expresses particular intermediary inputs as portion to the final output. One element nm shows the portion of good n for producing the final output of activity m . In other words, for each activity the column vector shows the ratio of intermediary inputs for producing the entire output of activity m . It includes all inputs necessary for the production of output of activity m , both characteristic as well as non-characteristic goods.³³⁹

³³⁶ United Nations (1968); The SNA provides a comprehensive and detailed framework for the systematic and integrated recording of the flows and stocks of an economy.

³³⁷ Statistik Austria (2010)

³³⁸ Compare Bayerl (2008), p. 12

³³⁹ Compare Fleischmann and Rainer (1985), pp. 11-12 ; or Bayerl (2008), p. 12

$$B = U * \langle g \rangle^{-1} = \begin{pmatrix} U_{11} & U_{12} & \dots & U_{1m} \\ U_{21} & U_{22} & \dots & U_{2m} \\ \vdots & \vdots & \vdots & \vdots \\ \vdots & \vdots & \vdots & \vdots \\ U_{n1} & U_{n2} & \dots & U_{nm} \end{pmatrix} \times \begin{pmatrix} \frac{1}{g_1} & 0 & 0 & \dots & 0 \\ 0 & \frac{1}{g_2} & 0 & \dots & 0 \\ \vdots & \vdots & \vdots & \vdots & \vdots \\ 0 & 0 & 0 & 0 & \frac{1}{g_m} \end{pmatrix} = \begin{pmatrix} \frac{U_{11}}{g_1} & \frac{U_{12}}{g_2} & \dots & \frac{U_{1m}}{g_m} \\ \frac{U_{21}}{g_1} & \frac{U_{22}}{g_2} & \dots & \frac{U_{2m}}{g_m} \\ \vdots & \vdots & \vdots & \vdots \\ \frac{U_{n1}}{g_1} & \frac{U_{n2}}{g_2} & \dots & \frac{U_{nm}}{g_m} \end{pmatrix} \quad (5)^{340}$$

where

B ... Matrix of intermediary input coefficients (n x m)

U ... Intermediary use matrix (n x m)³⁴¹

$\langle g \rangle$.. Diagonalized column vector of revenues of production (m x m)

The matrix of intermediary input coefficients is composed in a way that each element of the intermediary use matrix is divided by the sum of the corresponding column vector g_m .

(2) Market-shares matrix

The market-shares matrix (dimension: activities x goods) shows for each good the portion of particular activities on the entire production of the specific good. An element mn expresses the portion of activity m on the entire domestic output of a specific good n . The market-shares matrix comprises ratios where the sum of columns is 1.³⁴² The market-shares matrix includes both domestic as well as imported inputs.

$$D = V' * \langle q \rangle^{-1} = \begin{pmatrix} V_{11} & V_{21} & \dots & V_{m1} \\ V_{12} & V_{22} & \dots & V_{m2} \\ \vdots & \vdots & \vdots & \vdots \\ \vdots & \vdots & \vdots & \vdots \\ V_{1n} & V_{2n} & \dots & V_{mn} \end{pmatrix} \times \begin{pmatrix} \frac{1}{q_1} & 0 & 0 & \dots & 0 \\ 0 & \frac{1}{q_2} & 0 & \dots & 0 \\ \vdots & \vdots & \vdots & \vdots & \vdots \\ 0 & 0 & 0 & 0 & \frac{1}{q_m} \end{pmatrix} = \begin{pmatrix} \frac{V_{11}}{q_1} & \frac{V_{21}}{q_2} & \dots & \frac{V_{m1}}{q_m} \\ \frac{V_{12}}{q_1} & \frac{V_{22}}{q_2} & \dots & \frac{V_{m2}}{q_m} \\ \vdots & \vdots & \vdots & \vdots \\ \frac{V_{1n}}{q_1} & \frac{V_{2n}}{q_2} & \dots & \frac{V_{mn}}{q_m} \end{pmatrix} \quad (6)^{343}$$

where

D ... Market-shares matrix (m x n)

V' ... Transposed make-matrix (m x n)³⁴⁴

³⁴⁰ Depiction follows Holub and Schnabl (1994), p. 61

³⁴¹ The use-matrix (goods x activities) displays the use of goods either as intermediary inputs for goods' production or for final demand. It therefore shows goods classified by usage categories, i.e. inputs for production as well as final demand (compare Statistik Austria (2010), p. 13). Furthermore, the use-matrix includes information about added values, i.e. salaries, taxes on production as well as subsidies, depreciation and profits.

³⁴² Compare Fleischmann and Rainer (1985), p. 12 ; or Bayerl (2008), p. 12

³⁴³ Depiction follows Holub and Schnabl (1994), p. 61

$\langle q \rangle$.. Diagonalized column vector of goods use ($n \times n$)

(3) Product-mix matrix

The product-mix matrix (dimension: goods x activities) shows the relation of goods output of a respective activity to the entire output of this activity. In other words, it shows the relative proportion (product-mix) of a specific good produced by an activity compared to all goods produced by this activity. With the help of this matrix the level of specialization of a respective activity can be shown. In the extreme case of specialization of each activity to only one good, the make-matrix includes only elements at the main diagonal.³⁴⁵

However, in the chosen approach for constructing the technology matrix and subsequently the symmetric input-output table, no product-mix matrix is necessary. This statement is linked with the choice of technology assumption, described later on in this section.

Constructing a technology matrix by dealing with technology assumptions

By using the “coefficient matrices” a technology matrix can be deduced, necessary for constructing the inter-industry input-output relation. The technology matrix shows the relation between intermediary use and final output per activity. However, at deducing the technology matrix special attention is laid on “non-characteristic products”. These are products which are produced by industries usually and mainly producing other products. If one industry produces both “characteristic” and “non-characteristic” goods, it is not obvious at the beginning in which manner particular intermediary inputs are assigned to different products produced by one industry. Therefore, wherever a certain good is produced by an industry not mainly producing this specific good, the corresponding production technology for that good cannot straightforward be deduced from the use-matrix. This data source only displays structures of inputs for the entire production of a specific industry. Therefore, if at least one good is produced in an industry mainly producing another good, there is a need for setting a technology assumption.³⁴⁶ This technology assumption either defines that also non-characteristic goods of an industry are produced by the same technology typically used for producing the “main good” in that industry³⁴⁷, or that these non-characteristic goods are produced by the technology typically used for producing them, no matter in which industry they are produced.³⁴⁸ These two contrary approaches are also known in the literature as “industry technology assumption” and “goods technology assumption” respectively.³⁴⁹ Both approaches are the two extreme cases, variations of results are higher the higher the significance of non-characteristic production.³⁵⁰

³⁴⁴ The make-matrix (goods x activities) shows the production values of goods produced by particular activities – in this case expressed in manufacturing-costs. In other words, it shows the entire amount of goods (expressed in monetized values) of domestic production as well as imported production (compare Statistik Austria (2010); p. 13).

³⁴⁵ Compare Bayerl (2008); p. 13

³⁴⁶ See also Holub and Schnabl (1994), p. 64

³⁴⁷ See also Holub and Schnabl (1994), p. 64

³⁴⁸ See also Holub and Schnabl (1994), p. 66

³⁴⁹ Compare Bayerl (2008); p. 14

³⁵⁰ Compare Bayerl (2008); p. 11

For deducing the technology matrix A , in the present study the industry technology assumption was applied with the dimension activity \times activity. Thereby the make-matrix is weighted information about market-shares.

$$A_{I, A \times A} = D \times B \tag{7}^{351}$$

where

$A_{I, A \times A}$... Technology matrix (industry technology assumption, dimension activities \times activities)

D Market-shares matrix (m \times n)

B Matrix of intermediary input coefficients (n \times m)

There are pros and cons for each of the mentioned technology assumptions: From the viewpoint of the theory of production the “goods technology assumption” might be superior, however it might be problematic in certain cases.³⁵² Holub and Schnabl (1994) have detailed described and numerically proven that constructing the technology matrix via a goods technology assumption might result in negative coefficients.³⁵³ Therefore, this is one reason why statistics agencies often prefer the “industry technology assumption”.³⁵⁴

Input-output table: Inter-industry relations

For constructing the final table about inter-industry relations, information of the make-matrix is mixed with information about the industry structure (technology matrix). Taking the coefficients of the technology matrix as a_{ij} and V_j the respective column vector the make-matrix, then the final values of inter-industry relations X_{ij} are computed by

$$a_{ij} \times V_j = X_{ij} \tag{8}$$

Generating the new activity “MOBIL”

In the executed policy simulations inter alia a partial conversion of systems of drive – from conventional technology to natural gas based technology – is simulated. These policy simulations require an adaptation of the input-output-table by explicitly depicting all expenses for passenger transportation by cars. This includes expenses of both enterprises as well as for private consumers. For that a new activity called “MOBIL” is created, which combines all expenses needed for passenger mobility by cars.

To “unhinge” expenses for passenger mobility by cars the activity “land transport; transport via pipelines” (ÖNACE 60) was splitted into passenger transport by cars (ÖNACE 6022) – which was assigned to the newly created activity “MOBIL” – and the rest, which still belongs to the original activity. Furthermore, expenses for car-based passenger mobility from final

³⁵¹ Depiction follows Holub and Schnabl (1994), p. 65

³⁵² Compare Fleischmann and Rainer (1985), p. 18 ; or Bayerl (2008); p. 16; or Holub and Schnabl (1994), p. 67

³⁵³ Holub and Schnabl (1994), pp. 67-71; or Bayerl (2008); p. 16

³⁵⁴ Compare Fleischmann and Rainer (1985), p. 18

demands are assigned to the newly created activity. The magnitude of these expenses is derived from information of Statistics Austria³⁵⁵ which provides information about the pattern of expenditures of households. The distribution of the entire fleet of cars in Austria between being consumption goods (purchased by consumers) or investment goods (purchased by enterprises) is also generated from information provided by Statistics Austria³⁵⁶.

In a last step the initially highly disaggregated input-output-table (57 activities plus the new activity "MOBIL") has been aggregated to 35+1 activities including "MOBIL". This is necessary to enable a clear and straightforward overview of effects from policy simulations.

Attaching information about value added and final demand

For finalizing an input-output-table, information about value added as well as final demand has to be added to information about inter-industry relations.

Information about the various components of the block "value added" is provided by the National Bureau of Statistics.³⁵⁷ This block comprises information about governmental income as well as factor income from labor and capital. The total value added is seen as the difference between entire expenditures (= total output) and costs of intermediary inputs. Thus, the column vector W_j tells about the contributions of each activity to the GDP³⁵⁸.

Information about final demand is computed by combining information of the market-shares matrix (activities x goods) and the final demand component of the use-matrix (goods x categories). The block "final demand" includes information about consumption of private households and the government as well as about investments, variations in stocks as well as about exports.

Assembling the Input-Output-Table to a Social Accounting Matrix (SAM)

For constructing appropriate data inputs suitable for the simulation model, several components of the input-output-table have to be aggregated and slightly reassembled.

Information of the block "value added" was assembled to the components ITAX (indirect tax revenues), L (income from the primary factor labor), K (income from the primary factor capital) as well as their corresponding taxes LTAX and K TAX (tax on labor and tax on capital respectively).

In the model for small open economies all markets – except the labor market – are cleared. Thus, all produced goods as well as the entire value added has to be "taken over" either by industries for goods' production, by the households (= consumers) for consumption and

³⁵⁵ Statistik Austria (2006); pp.39-53

³⁵⁶ Overall amount of cars – amount of cars for private usage = amount of cars for entrepreneurial usage;
Overall amount of cars in Austria available at http://www.statistik.at/web_de/statistiken/verkehr/strasse/kraftfahrzeuge_-_bestand/index.html (May 6, 2010; "Kfz-Bestand 2008")

Overall amount of cars in Austria used by private households available at
http://www.statistik.at/web_de/statistiken/energie_und_umwelt/energie/energieeinsatz_der_haushalte/index.html (May 6, 2010);

"Fahrleistungen und Treibstoffeinsatz privater Pkw nach Bundesländer 2000-2008)

³⁵⁷ Statistik Austria (2010), table 12

³⁵⁸ Compare Bayerl (2008), p. 19

investment or by the government. Furthermore, goods are exported as well as imported. According to this, also the various components at the assignment side of the SAM were assembled.

In addition, information from the National Bureau of Statistics about unemployment benefits is included³⁵⁹. Information about flows in foreign exchange is derived from disparities in values of exports and imports. The value and the direction of tax transfers are computed as balancing value. Last but not least, information about employment in each activity is also based on information provided by the National Bureau of Statistics.³⁶⁰

10.5 ECONOMIC EFFECTS

In this section all economic effects of the different case studies are analyzed. Furthermore a comparison of case studies according to economic effects is made.

10.5.1 Economic effects of case study 1

In case study 1 it is assumed that the intended amount of GHG-reductions (100.000 tons) is raised by purchasing carbon offset certificates abroad. The representative (exemplarily iron and steel producing) installation purchases 80 % of the mentioned amount of certificates, the rest is purchased by the government.

Generally induced economic effects are rather minor given the relatively small amounts of traded GHG-reductions. However, the trend draws the following picture: In this case study, required funds for carbon offset certificates purchases of the representative installation (sector "EISEN") and the government are raised by contributions of the representative installation³⁶¹ and general taxation on domestic final demand for goods respectively. In this case study the effects from "fund raising" of the representative installation are – not surprising – the most affecting ones in this case study: The increase in sales prices of the representative installation's products deteriorates its competitiveness on the international market and therefore reduces this installation's exports. Reduced domestic economic activities caused by reduced exports of the representative installation lead also to decreasing tax revenues from primary inputs labor and capital ("direct taxes"). Similarly, a reduced sales volume reduces tax revenues on goods ("indirect taxes"³⁶²). Furthermore, the installation's output reduction leads to a decrease in its demand for initially both primary factors. However, as the representative installation produces capital-intensive, a reduction in its output leads to a release of capital to a higher extent compared to the release in labor. This – but also caused by the minimum wages constraint – lowers the price for capital more than the price for labor, which makes capital relatively less expensive. This leads to output increases in capital-intensive sectors and output decreases in labor-intensive sectors – once again less

³⁵⁹ Statistik Austria (2009), table 123_2

³⁶⁰ Statistik Austria (2010), table 41

³⁶¹ It is assumed that the installation is able to completely forward price increases to customers

³⁶² Sales taxes minus subsidies

labor is demanded. Therefore the government has to assign more funds for unemployment benefits. In sum, decreasing revenues from direct and indirect taxes as well as higher expenses for unemployment payments lead to a reduced public demand. This once again reduces – mainly domestic – economic activities and therefore GDP, which in turn reduces tax revenues etc. .

For keeping the capital account balanced, reduced exports must result in a decrease of the price level from domestic products (compared to foreign exchange if a fixed price for foreign exchange is assumed³⁶³). This in turn causes also prices of primary inputs to decrease, which lowers also the amount of tax revenues and therefore the public demand, which in turn adversely affects the value of GDP.

The consumer welfare is – on the one hand – positively affected by a (general) price decrease of goods (relative to foreign exchange), although the price in consumed goods decreases less than the price of domestically produced goods as also imported goods contribute to the consumption bundle. On the other hand also the consumer's income from primary input factors decrease – either by decreased demand and/or by the decrease of their price levels. Considering also declining consumer welfare effects due to the necessary purchase of carbon offset certificates from abroad, in sum the consumer welfare decreases. This is also the case for the government which faces lower prices for its demanded goods, but also decreases in revenues and increases in unemployment expenses. The consumer welfare effects of carbon offset purchases by the government are – relative to the amount of certificates purchased – comparable with the welfare effects from the installation's certificates' purchase. Other effects (GDP, unemployment, etc.) of the governmental actions are a negligible fraction. Table 17 provides an overview of economic effects in this case study.

Table 17 *Macroeconomic changes in case study 1*

GDP	Change in GDP (%)	-0.005
	Change in GDP (absolute value, Mio. €)	-10.9
Consumer Welfare	Change in Consumer Welfare (%)	-0.001
	Change in Consumer Welfare (absolute value, Mio. €)	-1.7
Employment	Change in employment (absolute value)	-108
Labor & Capital	Change in price for labor (%)	-0.002
	Change in price for capital (%)	-0.004
Government	Change in direct tax revenues (absolute value, Mio. €)	-3.2
	Change in indirect tax revenues (absolute value, Mio. €)	-0.8
	Change in expenditures for unemployed (absolute value, Mio. €)	0.5
	Change in public demand (absolute value, Mio. €)	-4.5
Govt. Welfare	Change in Government Welfare (absolute value, Mio. €)	-3.2

Source: own calculations with adapted version of the ACPI-model

³⁶³ Fixing the international price level is a quite plausible assumption for small and therefore price-taking economies

As mentioned above the economic simulation leads to price changes of the primary input factors labor and capital, whereas capital becomes relatively less expensive than labor. As a Leontief production function is assumed, the production process of a specific sector cannot shift between primary inputs.³⁶⁴ Changing relative prices between primary inputs rather leads to an increased output of capital-intensive sectors and a decreased output of labor-intensive sectors. This is caused by the fact that goods produced by labor-intensive sectors become relatively more expensive compared to goods produced by capital-intensive sectors. This is displayed in Table 18 whereas it is important to mention that sectoral effects are a result of the assumption that the representative installation is producing iron and steel. If the representative installation would be assigned to another sector, also (sectoral) effects would change.

³⁶⁴ The sensitivity analysis will analyze the effects of other CES production functions which allow the substitution between the primary input factors capital and labor to a certain extent.

Table 18 Sectoral economic changes in case study 1

	Acronym of sectors	Change Output (%)	Change exports (%)	Change imports (%)	Change price of domestic production (%)	Change price of domestic consumption (%)	Change value added (%)	Change employment (absolute)
1	LAWI	0.008	0.014	0	-0.003	-0.003	0	30
2	KOHL	-0.035	-0.057	0.002	0.015	0	-0.007	0
3	OELBB	0.007	0.012	-0.018	-0.003	0	0.003	0
4	OELVER	0.002	0.004	-0.003	-0.001	-0.001	-0.008	0
5	ELEK	-0.001	0.003	-0.005	-0.003	-0.002	-0.011	0
6	WASSER	0.001	0.005	-0.004	-0.003	-0.003	-0.004	0
7	EISEN	-0.16	-0.174	-0.053	0.008	0.009	-0.131	-75
8	STEIN	0.006	0.01	-0.004	-0.003	-0.003	-0.001	3
9	CHEMIE	0.198	0.2	0.029	-0.003	-0.002	0.191	78
10	METALL	-0.008	-0.008	-0.009	0	0	-0.009	-9
11	MASCH	0.001	0.002	-0.012	-0.002	-0.002	-0.004	1
12	BUEROM	-0.006	-0.003	-0.001	-0.003	0	-0.014	0
13	ELEINR	0.039	0.043	-0.003	-0.002	-0.002	0.034	30
14	FAHRZ	-0.114	-0.112	-0.051	-0.002	-0.003	-0.124	-72
15	NAHR	0.008	0.012	-0.002	-0.003	-0.003	-0.002	9
16	TEXTIL	-0.154	-0.152	-0.028	-0.003	-0.001	-0.161	-64
17	HOLZ	0.012	0.017	-0.003	-0.003	-0.004	0.001	6
18	PAPIER	0.037	0.041	0.012	-0.003	-0.005	0.026	9
19	VERLAG	0.004	0.009	-0.003	-0.003	-0.003	-0.004	2
20	GUMMI	0.015	0.019	-0.011	-0.002	-0.002	0.009	6
21	RECYC	-0.096	-0.097	-0.094	0.001	0.001	-0.093	-2
22	SPROD	0.008	0.012	-0.012	-0.002	-0.002	0.002	7
23	BAU	-0.001	0	-0.002	-0.003	-0.003	-0.007	-4
24	HANDEL	-0.001	0.002	-0.005	-0.003	-0.003	-0.006	-9
25	GAST	0.001	0.004	-0.003	-0.003	-0.003	-0.004	3
26	VERK	0.006	0.011	-0.006	-0.003	-0.003	0	9
27	SUL	0.008	0.013	-0.004	-0.002	-0.002	-0.002	1
28	SVERK	0.002	0.007	-0.004	-0.003	-0.003	-0.006	2
29	KOMM	0.001	0.004	-0.004	-0.003	-0.003	-0.006	0
30	GELD	-0.001	0.001	-0.003	-0.003	-0.004	-0.006	-1
31	REAL	0	0.001	-0.002	-0.004	-0.004	-0.006	0
32	DATEN	0.001	0.003	-0.001	-0.003	-0.004	-0.005	1
33	FUE	-0.001	0.001	-0.003	-0.003	-0.003	-0.006	-3
34	SODIEN	0	0.002	-0.003	-0.003	-0.003	-0.005	0
35	NMDIEN	-0.005	-0.004	-0.006	-0.003	-0.003	-0.009	-68
36	MOBIL	-0.001	0.002	-0.004	-0.003	-0.003	-0.12	0

Source: own calculations with adapted version of the ACPI-model

10.5.2 Economic effects of case study 2/2+

In case study 2 it is assumed, that the representative installation still covers 80 % of intended GHG-reductions by purchasing offset certificates from abroad. The government, however, extends the financial endowment of an existing and effective subsidy scheme for stimulating additional investments in natural gas powered cars, which results in achieving the remaining 20 % of intended GHG-reductions. Funds for extending the financial endowment of the mentioned subsidy scheme are raised by a common endogenous tax on all goods and services sold domestically.

Equally to case study 1 induced economic effects are rather minor given the relatively small amounts of traded GHG-reductions. Alike in case study 1, also at this simulation the

representative installation's required funds for purchasing carbon offset certificates (80 % of intended GHG-abatements) are raised only by contributions of the representative installation³⁶⁵ (sector "EISEN") itself. Impacts and the mode of impacts of purchasing a certain amount of carbon offset certificates from abroad are equal to case study 1. Moreover, the major part of effects on GDP, employment, tax revenues and public demand are caused by certificates purchases from abroad. The most interesting net effects of the installation's certificates purchase from abroad are summarized in Table 19.

Table 19 Net effect of representative installation's certificates purchase

GDP	Change in GDP (absolute value, Mio. €)	-11.3
Employment	Change in employment (absolute value)	-58
Consumer Welfare	Change in Consumer Welfare (absolute value, Mio. €)	-1.5
Govt. Welfare	Change in Government Welfare (absolute value, Mio. €)	-3.5

Source: own calculations with adapted version of the ACPI-model

However, the now interesting effects are those caused by introducing – firstly – a more efficient technology and – secondly – a general taxation on final demand in order to generate funds for the extra-financial endowment of the existing subsidy scheme under consideration.

In general, as labor becomes relatively more expensive than capital (caused by actions of the sector EISEN), demand for the labor-intensive sector MOBIL decreases. However, this trend is countered for this sector as the now increasingly used technology "natural gas powered cars" requires fossil fuels to a lower extent and therefore MOBIL becomes relatively cheap. Nevertheless, increasing demand for the now cheaper good of MOBIL is restricted by the narrowed price-demand-elasticities for substitution of industries, representative consumer and government. Simultaneously, reduced demand for fossil fuels induces a decrease in demand of the sector HANDEL which provides fossil fuels. As HANDEL is more labor-intensive than the general economy, the so induced release in labor cannot be entirely absorbed by the general economy. In sum, using the new technology leads to a release of labor and therefore to a – slight – reduction of GDP. Also consumer welfare and government welfare is slightly reduced due to the reduction in income caused by idle manpower and therefore reduced revenues of direct taxes. This reduction in income and tax revenues cannot entirely be balanced by the benefits of the now cheaper good MOBIL.

However, to get a more comprehensive view it is necessary to look not only on the effect of introducing a more efficient technology but also to the effects of financing, that means on the effect of imposing a tax on domestically purchased goods for subsidizing the good of sector MOBIL. Imposing a tax on domestically consumed goods does not harm the competitiveness of domestic goods with foreign goods, but rather increases the domestic value added. However, finally all tax revenues for subsidizing the sector MOBIL have to be paid by the consumer and the government. Certainly, consumer and government benefit from reduced sales prices caused by subsidies, however, also exported products become cheaper. From

³⁶⁵ It is assumed that the installation is able to completely forward price increases to customers

that the consumer does not benefit to an extent necessary to be completely compensated for paid taxes. Therefore mainly consumer welfare is reduced but also – induced by the consumer's consumption change – the government's welfare.

In sum, using fairly high amounts for attracting individuals for switching to the “new” natural gas technology leads to slight increases in value added but decreases in consumer welfare and government welfare (Table 20).

Table 20 Net effect of government's actions in case study 2

GDP	Change in GDP (absolute value, Mio. €)	0.8
Employment	Change in employment (absolute value)	-34
Consumer Welfare	Change in Consumer Welfare (absolute value, Mio. €)	-3.5
Govt. Welfare	Change in Government Welfare (absolute value, Mio. €)	-1.3

Source: own calculations with adapted version of the ACPI-model

Taking together the effects of the representative installation's and the government's actions it turns out that the adverse effect on GDP and government welfare is mainly caused by the representative installation's action. Consumer welfare – in turn – is mainly affected by the government's actions of imposing a relatively high tax on domestic consumption, which has to be paid by the consumer to a major extent (Table 21).

Table 21 Macroeconomic changes in case study 2

GDP	Change in GDP (%)	-0.004
	Change in GDP (absolute value, Mio. €)	-10.5
Consumer Welfare	Change in Consumer Welfare (%)	-0.003
	Change in Consumer Welfare (absolute value, Mio. €)	-5
Employment	Change in employment (absolute value)	-144
Labor & Capital	Change in price for labor (%)	-0.002
	Change in price for capital (%)	-0.007
Government	Change in direct tax revenues (absolute value, Mio. €)	-4.1
	Change in indirect tax revenues (absolute value, Mio. €)	-0.9
	Change in expenditures for unemployed (absolute value, Mio. €)	0.7
	Change in public demand (absolute value, Mio. €)	-5.7
Govt. Welfare	Change in Government Welfare (absolute value, Mio. €)	-4.5

Source: own calculations with adapted version of the ACPI-model

Compared to the international price level both prices for primary inputs labor and capital decline, whereas price for capital declines more than price for labor. Reasons for that are, firstly, that sector EISEN – this sector which is supposed to increase its sales prices for raising funds and subsequently is forced to reduce its output – is producing capital-intensive. Secondly, the minimum wage applied in the model constrains the decrease of the price for

labor compared to the numeraire. Assuming a Leontief production function³⁶⁶ labor-intensive sectors relatively reduce their production while capital-intensive sectors relatively extent their production (Table 22).

Table 22 Sectoral economic changes in case study 2

	Acronym of sectors	Change Output (%)	Change exports (%)	Change imports (%)	Change price of domestic production (%)	Change price of domestic consumption (%)	Change value added (%)	Change employment (absolute)
1	LAWI	0.008	0.018	-0.003	-0.005	-0.003	-0.002	22
2	KOHLE	-0.029	-0.049	0.004	0.013	0.001	-0.004	0
3	OELBB	0.022	0.028	-0.016	-0.004	0	0.015	0
4	OELVER	0.006	0.008	0.002	-0.001	0	-0.002	0
5	ELEK	-0.001	0.003	-0.005	-0.002	-0.002	-0.011	0
6	WASSER	0	0.006	-0.006	-0.004	-0.003	-0.005	0
7	EISEN	-0.158	-0.171	-0.051	0.008	0.01	-0.129	-48
8	STEIN	0.006	0.012	-0.004	-0.003	-0.003	-0.001	2
9	CHEMIE	0.235	0.237	0.034	-0.003	-0.002	0.227	61
10	METALL	-0.008	-0.007	-0.009	-0.001	0	-0.009	-5
11	MASCH	0.002	0.004	-0.012	-0.002	-0.002	-0.003	2
12	BUEROM	-0.008	-0.005	-0.003	-0.004	0	-0.017	0
13	ELEINR	0.043	0.047	-0.003	-0.002	-0.002	0.037	22
14	FAHRZ	-0.102	-0.1	-0.045	-0.002	-0.002	-0.111	-42
15	NAHR	0.007	0.013	-0.004	-0.003	-0.003	-0.004	5
16	TEXTIL	-0.166	-0.164	-0.031	-0.003	-0.001	-0.174	-45
17	HOLZ	0.012	0.018	-0.004	-0.004	-0.004	0	4
18	PAPIER	0.041	0.046	0.014	-0.004	-0.004	0.029	7
19	VERLAG	0.003	0.008	-0.005	-0.004	-0.003	-0.006	1
20	GUMMI	0.019	0.023	-0.01	-0.003	-0.002	0.012	5
21	RECYC	-0.094	-0.094	-0.093	0	0.001	-0.092	-1
22	SPROD	0.009	0.014	-0.013	-0.003	-0.002	0.003	6
23	BAU	-0.003	-0.001	-0.004	-0.003	-0.002	-0.009	-6
24	HANDEL	-0.007	-0.003	-0.012	-0.004	-0.004	-0.014	-40
25	GAST	0	0.004	-0.006	-0.004	-0.003	-0.007	-1
26	VERK	0.006	0.012	-0.007	-0.003	-0.003	0	6
27	SUL	0.006	0.01	-0.005	-0.002	-0.001	-0.004	1
28	SVERK	0.001	0.006	-0.005	-0.003	-0.002	-0.007	1
29	KOMM	0	0.004	-0.006	-0.004	-0.003	-0.009	0
30	GELD	0	0.002	-0.003	-0.004	-0.004	-0.007	0
31	REAL	-0.001	0.002	-0.004	-0.006	-0.005	-0.009	-1
32	DATEN	0	0.002	-0.003	-0.004	-0.003	-0.008	0
33	FUE	-0.001	0.001	-0.004	-0.004	-0.003	-0.008	-3
34	SODIEN	-0.002	0.002	-0.005	-0.004	-0.003	-0.008	-2
35	NMDIEN	-0.007	-0.006	-0.009	-0.003	-0.002	-0.011	-66
36	MOBIL	-0.174	0	-0.007	-0.003	-0.002	-0.283	-27

Source: own calculations with adapted version of the ACPI-model

However, discussed macroeconomic effects as well as effects on the economic consumer and government welfare are a result of the assumption that the mentioned governmental actions are only successful at the presence of a rather high subsidy rate. However, one could assume that the government is much more successful in attracting individuals willing to purchase cars with the natural gas technology rather than purchasing conventional ones.

³⁶⁶ The sensitivity analysis will analyze the effects of other CES production functions which allow the substitution between the primary input factors capital and labor to a certain extent.

Therefore a sub-case study is conducted – case study 2+ – which assumes that the government is only marginally less successful than private DOP-developers analysed in case study 3.

Based on this adjusted assumption about the extent of subsidies necessary to attract individuals it turns out that economic welfare both for the consumer as well as for the government does decrease to a lower extent than in case study 2. GDP decreases a bit more because revenues from the tax imposed on domestic demand – which are assigned to the national value added – are lower than in case study 2 (Table 23)

Table 23 *Macroeconomic changes in case study 2+*

GDP	Change in GDP (%)	-0.005
	Change in GDP (absolute value, Mio. €)	-11.8
Consumer Welfare	Change in Consumer Welfare (%)	-0.001
	Change in Consumer Welfare (absolute value, Mio. €)	-1.8
Employment	Change in employment (absolute value)	-129
Labor & Capital	Change in price for labor (%)	-0.003
	Change in price for capital (%)	-0.004
Government	Change in direct tax revenues (absolute value, Mio. €)	-3.8
	Change in indirect tax revenues (absolute value, Mio. €)	-0.9
	Change in expenditures for unemployed (absolute value, Mio. €)	0.6
	Change in public demand (absolute value, Mio. €)	-5.3
Govt. Welfare	Change in Government Welfare (absolute value, Mio. €)	-3.7

Source: own calculations with adapted version of the ACPI-model

Sectoral effects are similar to the argumentation described in case study 2 (Table 24).

Table 24 Sectoral economic changes in case study 2+

	Acronym of sectors	Change Output (%)	Change exports (%)	Change imports (%)	Change price of domestic production (%)	Change price of domestic consumption (%)	Change value added (%)	Change employment (absolute)
1	LAWI	0.008	0.015	0	-0.004	-0.003	0.001	23
2	KOHL	-0.031	-0.052	0.006	0.014	0	-0.003	0
3	OELBB	0.015	0.02	-0.014	-0.003	0	0.01	0
4	OELVER	0.008	0.01	0.003	-0.001	-0.001	-0.002	0
5	ELEK	0	0.005	-0.004	-0.003	-0.003	-0.011	0
6	WASSER	0.001	0.006	-0.004	-0.003	-0.003	-0.004	0
7	EISEN	-0.153	-0.166	-0.05	0.008	0.009	-0.125	-48
8	STEIN	0.007	0.012	-0.004	-0.003	-0.003	-0.001	3
9	CHEMIE	0.225	0.226	0.033	-0.003	-0.003	0.216	59
10	METALL	-0.008	-0.008	-0.01	-0.001	-0.001	-0.011	-6
11	MASCH	0.003	0.004	-0.013	-0.002	-0.003	-0.003	2
12	BUEROM	-0.006	-0.003	-0.001	-0.004	0	-0.016	0
13	ELEINR	0.048	0.053	-0.004	-0.002	-0.003	0.042	25
14	FAHRZ	-0.133	-0.131	-0.058	-0.003	-0.003	-0.146	-57
15	NAHR	0.009	0.014	-0.003	-0.003	-0.004	-0.002	7
16	TEXTIL	-0.176	-0.174	-0.032	-0.003	-0.002	-0.184	-49
17	HOLZ	0.013	0.019	-0.003	-0.004	-0.005	0.001	5
18	PAPIER	0.041	0.047	0.013	-0.004	-0.005	0.03	7
19	VERLAG	0.004	0.009	-0.005	-0.004	-0.004	-0.006	1
20	GUMMI	0.018	0.022	-0.013	-0.003	-0.003	0.01	5
21	RECYC	-0.091	-0.091	-0.09	0	0	-0.09	-1
22	SPROD	0.01	0.014	-0.013	-0.003	-0.003	0.003	6
23	BAU	-0.001	0	-0.003	-0.003	-0.003	-0.008	-3
24	HANDEL	-0.007	-0.003	-0.011	-0.004	-0.004	-0.013	-39
25	GAST	0.001	0.004	-0.004	-0.004	-0.004	-0.005	2
26	VERK	0.007	0.013	-0.006	-0.003	-0.004	0	8
27	SUL	0.009	0.014	-0.005	-0.003	-0.002	-0.003	1
28	SVERK	0.003	0.008	-0.004	-0.003	-0.003	-0.006	2
29	KOMM	0	0.004	-0.004	-0.004	-0.004	-0.008	0
30	GELD	0.001	0.002	-0.002	-0.004	-0.004	-0.006	1
31	REAL	-0.001	0.001	-0.003	-0.004	-0.004	-0.007	0
32	DATEN	0.001	0.003	-0.002	-0.004	-0.004	-0.006	1
33	FUE	-0.001	0.001	-0.003	-0.003	-0.004	-0.008	-3
34	SODIEN	0	0.002	-0.004	-0.004	-0.003	-0.006	-1
35	NMDIEN	-0.006	-0.005	-0.007	-0.003	-0.003	-0.01	-53
36	MOBIL	-0.171	0.003	-0.005	-0.003	-0.003	-0.307	-27

Source: own calculations with adapted version of the ACPI-model

10.5.3 Economic effects of case study 3

In case study 3 no purchases for carbon offset certificates from abroad are done. Rather, intended GHG-reductions are raised by Domestic Offset Projects accomplished or stimulated by the representative installation. For that, the representative installation provides limited “subsidies”, low enough to be attractive for the installation compared to purchasing CO₂-offset certificates from abroad. The government raises its 20 % by discounting the amount of ERUs issued in exchange for real GHG-reductions induced by DOPs.³⁶⁷

The interpretation of economic effects of case study 3 can basically be assembled from the case studies before. As displayed in Table 25 the negative effects on GDP and employment

³⁶⁷ See chapter 9.3 for details of the discounting procedure

are caused by two reasons: Firstly, price increases of goods from the sector EISEN (caused by its “fund raising”) leads this sector’s goods to become less competitive against comparable goods from abroad. This disadvantage in international competitiveness results in reduced output of domestic production and reduced GDP. But not only international competitiveness is harmed. A price increase in the sector EISEN leads also to decreasing domestic consumption of goods from EISEN, which decreases the output of the sector EISEN too.

Additionally to that the more efficient technology “natural gas powered cars” is implemented to a now (compared to case study 2/2+) considerable extent. In line of the argumentation of case study 2/2+ the positive effects for consumer as well as government welfare of providing MOBIL at lower costs is overbalanced by negative effects in previous process chains, e.g. that released labor in the fossil fuel providing sector HANDEL cannot be entirely absorbed by the general economy. Idle manpower results in lower consumer income and therefore in lower demand for (also domestically produced) goods.

The remaining interpretation is pretty much similar to the case studies before: Reduced value of domestic production – in terms of the numeraire foreign price level (!) – leads to a decrease in prices for the primary inputs labor and capital. Reduced economic activities as well as reduced deployment/prices of the primary input factors labor and capital causes reductions in revenues from direct (taxes on labor and capital) as well as indirect taxes (taxes on goods). Furthermore, the government has to spend more for unemployment benefits as unemployment rises. As the tax deficits and additional expenditures need to be financed (assuming no new public debts) the government has to reduce its demand for goods, which in turn leads to a decrease in (mainly) domestic output and therefore GDP, to an increase in unemployment, to higher tax deficits and therefore reduced public demand. These effects lead to an intensified release of primary inputs, which in turn decreases their prices and lowers once again the income for consumers.

However, although both the nominal consumer’s income (from decreasing primary input factors revenues and increased unemployment) as well as the nominal government’s income (from decreasing tax revenues and increasing unemployment expenses) decline in absolute terms their welfare is only reduced to a lesser extent. This is because not only incomes decline but also the goods’ price levels decrease, i.e the real income declines to a lower extent than the nominal income.

Table 25 *Macroeconomic changes in case study 3*

GDP	Change in GDP (%)	-0.006
	Change in GDP (absolute value, Mio. €)	-14.7
Consumer Welfare	Change in Consumer Welfare (%)	-0.001
	Change in Consumer Welfare (absolute value, Mio. €)	-2.4
Employment	Change in employment (absolute value)	-248
Labor & Capital	Change in price for labor (%)	-0.006
	Change in price for capital (%)	-0.006
Government	Change in direct tax revenues (absolute value, Mio. €)	-7.3
	Change in indirect tax revenues (absolute value, Mio. €)	-1.5
	Change in expenditures for unemployed (absolute value, Mio. €)	1.2
	Change in public demand (absolute value, Mio. €)	-9.8
Govt. Welfare	Change in Government Welfare (absolute value, Mio. €)	-6.9

Source: own calculations with adapted version of the ACPI-model

The directions of sectoral effects are comparable to those in the previous case studies. Compared to the fixed price level of foreign exchange the price for the primary input capital declines more than the price for labor –caused by constraints for a labor price decrease. Assuming a Leontief production function labor-intensive sectors relatively reduce their production while capital-intensive sectors relatively extent their production (Table 26).

Table 26 Sectoral economic changes in case study 3

	Acronym of sectors	Change Output (%)	Change exports (%)	Change imports (%)	Change price of domestic production (%)	Change price of domestic consumption (%)	Change value added (%)	Change employment (absolute)
1	LAWI	0.014	0.024	0.001	-0.006	-0.005	0.002	24
2	KOHL	-0.013	-0.031	0.018	0.012	0	0.01	0
3	OELBB	0.05	0.058	0.004	-0.005	-0.001	0.042	0
4	OELVER	0.027	0.03	0.018	-0.002	-0.001	0.009	0
5	ELEK	0.009	0.016	0	-0.005	-0.005	-0.011	1
6	WASSER	0.002	0.011	-0.007	-0.006	-0.006	-0.007	0
7	EISEN	-0.111	-0.12	-0.039	0.005	0.006	-0.092	-22
8	STEIN	0.014	0.023	-0.005	-0.006	-0.006	0	3
9	CHEMIE	0.385	0.388	0.059	-0.006	-0.005	0.372	66
10	METALL	-0.01	-0.007	-0.018	-0.003	-0.004	-0.019	-5
11	MASCH	0.012	0.016	-0.023	-0.005	-0.006	-0.002	6
12	BUEROM	-0.01	-0.005	-0.002	-0.006	-0.001	-0.026	0
13	ELEINR	0.101	0.11	-0.006	-0.005	-0.005	0.087	34
14	FAHRZ	-0.272	-0.266	-0.116	-0.006	-0.007	-0.298	-75
15	NAHR	0.015	0.024	-0.005	-0.006	-0.006	-0.004	7
16	TEXTIL	-0.311	-0.307	-0.058	-0.005	-0.003	-0.325	-56
17	HOLZ	0.024	0.035	-0.005	-0.006	-0.009	0.003	6
18	PAPIER	0.071	0.08	0.022	-0.006	-0.009	0.05	8
19	VERLAG	0.004	0.013	-0.011	-0.006	-0.006	-0.013	1
20	GUMMI	0.032	0.04	-0.025	-0.005	-0.005	0.018	6
21	RECYC	-0.062	-0.059	-0.067	-0.002	-0.002	-0.07	-1
22	SPROD	0.019	0.027	-0.025	-0.006	-0.005	0.006	7
23	BAU	-0.001	0.002	-0.004	-0.006	-0.006	-0.013	-2
24	HANDEL	-0.031	-0.025	-0.04	-0.006	-0.007	-0.042	-119
25	GAST	0.002	0.007	-0.006	-0.006	-0.006	-0.008	2
26	VERK	0.015	0.026	-0.009	-0.006	-0.006	0.003	10
27	SUL	0.015	0.025	-0.01	-0.005	-0.004	-0.006	1
28	SVERK	0.006	0.014	-0.007	-0.006	-0.006	-0.011	2
29	KOMM	-0.001	0.005	-0.009	-0.006	-0.006	-0.014	0
30	GELD	0.002	0.005	-0.003	-0.006	-0.007	-0.009	1
31	REAL	-0.003	0	-0.006	-0.006	-0.006	-0.012	-1
32	DATEN	0.002	0.005	-0.003	-0.006	-0.007	-0.011	1
33	FUE	-0.002	0.001	-0.006	-0.006	-0.006	-0.014	-5
34	SODIEN	-0.001	0.004	-0.007	-0.006	-0.006	-0.011	-1
35	NMDIEN	-0.011	-0.008	-0.013	-0.006	-0.006	-0.019	-63
36	MOBIL	-0.841	0.006	-0.008	-0.006	-0.006	-1.084	-85

Source: own calculations with adapted version of the ACPI-model

10.5.4 Comparison of case studies

For a comparison of different ways of how to achieve a certain reduction of greenhouse gases, the GDP might not provide the best decision guidance. For instance, taxation on goods leads to different – positive as well as negative – effects on GDP, depending on whether domestically produced goods or domestic final demand are charged with a tax. In each case, however, the consumer is worse off as the portfolio of goods available for consumer's use is lessened taking also into account declining prices for goods.

Thus, for deciding which way of achieving GHG-reductions should be chosen, it might be a step forward to use consumer's welfare paired with government's welfare³⁶⁸ as decision

³⁶⁸ For a detailed definition of consumer and government welfare see chapter 10.2

guidance, which is the bundle of goods affordable by the consumer and government respectively after changed incomes and changed prices for goods.³⁶⁹

The analysis of all case studies shows a declining economic welfare effect, both for the consumer as well as for the government, as depicted in Figure 37. The reduction in consumer's income is caused on the one hand by a transfer of capital to abroad due to the purchase of carbon offset certificates (case studies 1, 2, 2+). On the other hand, due to reduced economic outputs the consumer faces a loss in income from primary factors capital and labor, which cannot be balanced by the highly moderate decline in the general price level for goods. Also the government is affected from reduced economic values of domestic outputs, as this affects tax revenues and unemployment expenditures. The reduced income and increased expenditures require a reduction of the government's goods demand although the general price level of goods declines.

Figure 37 Economic welfare effects (in Mio. €) of analyzed case studies

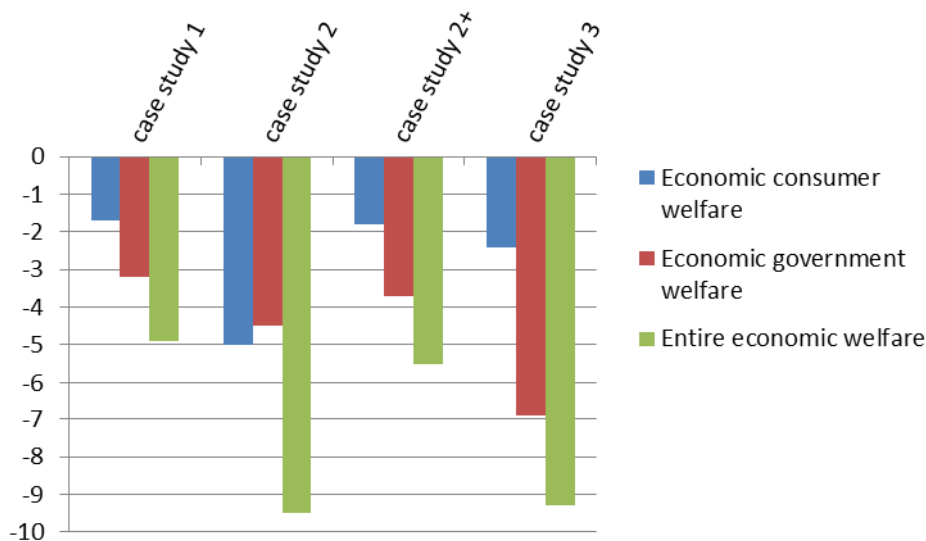

Source: own calculations from case study 1, 2, 2+, 3

As shown in Figure 37 the government's welfare is strongest affected in case study 3, where both the "fund raising" of the sector EISEN as well as the reduced economic activity due to less fuel consumption cause the highest decrease in tax revenues and increase in unemployment expenditures. The consumer's welfare is strongest affected in case study 2 where fairly high taxes on domestically consumed goods were assumed to be imposed. Assuming a lower tax rate on domestically consumed goods comparable with a rate necessary to gather funds for purchasing carbon offset certificates from abroad, the effect on the consumer's welfare is much lower (shown in case study 2+).

³⁶⁹ As mentioned in chapter 10.2 already the consumer's and government's welfare indicator is based on the Hicksian monetary measure of utility change, the equivalent variation.

It turns out from this analysis that the negative economic welfare effects of case study 3 are only exceeded by the negative economic welfare effects of case study 2 where a high tax rate on domestic consumption was assumed. However, it has to be kept in mind that only case study 3 achieves considered GHG-abatements entirely domestically. Thus it is necessary to extend this consideration of well-being of individuals by an additional ecologic component, described in chapter 10.6. . Moreover, it should also be kept in mind that achieving GHG reductions entirely domestically also sustainably lowers the level of domestic GHG emissions in subsequent compliance periods. This alleviates achieving later GHG-emissions reduction targets.

10.6 EFFECTS INCLUDING EXTERNAL COSTS

As mentioned in the previous section, the variables GDP or unemployment rates etc. might be good indicators for the economic well-being of a country's inhabitants. However, more meaningful in this respect might be the variables "consumer welfare" and "government welfare", whereas the latter could be seen as part of the former, but is depicted here separately for illustrative reasons. However, also these variables depict only changes of consumers' economic well-being, not including other aspects which determine overall well-being of the consumers. Certainly, a comprehensive consideration of all aspects determining overall well-being – as provided for instance by the Human Development Index (HDI) – would go beyond the scope of this study.³⁷⁰ However, in this analysis the variables "consumer welfare" and "government welfare" should be extended by changing external effects due to respective climate protection measures assumed in the three considered case studies. This could be seen as an approach to combine environmental improvements with the purely economic indicator for inhabitants' well-being.

10.6.1 Costs of external effects

There exists a great variety of (reduced or increased) external effects due to climate protection measures.³⁷¹ They include for instance noise, damages of carbon dioxide due to climate change, damages of harmful local air pollutants on human health and ecosystems or consumption of fossil resources.

Many studies³⁷² have intensively tried to quantify the magnitude of these external effects. Data exist mainly for damages due to emissions of harmful local air pollutants.³⁷³ However, their estimated data is substantially different, e.g. due to different assumptions about discount rates. The harmfulness of air pollutants depends on where they are emitted. Therefore a difference in reduced negative external effects arises depending on whether air pollutants get reduced domestically or abroad. Hence, this kind of external effects will be included in the

³⁷⁰ The broad spectrum of the Human Development Index (HDI) attempts to evaluate overall well-being not only on economic indicators, but also for instance on life expectancy at birth and mean years of schooling.

³⁷¹ See for instance Steiner (2006) or Krupnick, Burtraw, Markandya (2000)

³⁷² See for instance Holland et al. (2005) or Bickel, Friedrich (2005)

³⁷³ For instance Holland et al. (2005) or Hohmeyer (2002)

further analysis. Wide ranges of valuation exist also for marginal damage costs of greenhouse gas emissions as carbon dioxide. Difficulties for quantification mainly arise not only by the question of discounting but also due to uncertainties about the magnitude of adverse effects from climate change and due to other calculating assumptions.³⁷⁴ However, reduced damage costs of GHGs are not included in the analysis, as it does not matter for climate protection purposes whether GHGs are abated domestically or abroad. Also huge differences in data exist about the externality category “consumption of (fossil) resources” as this category is refused to be an externality by certain studies.³⁷⁵ Furthermore, the externality “noise”, largely recognized as externality category³⁷⁶ is not relevant in the present study: In all three different case studies analyzed in this paper it is not anticipated that noise is going to be reduced. Rather noise stays the same in all case studies including domestic actions as traffic stays the same – only the power engines of passenger cars would be different in specific case studies.

Thus, for extending the variables “consumer welfare” and “government welfare” by welfare effects from reduced externalities, only the category “externalities from harmful local air pollutants” remains adequate.³⁷⁷ Table 27 shows the ranges of external costs per harmful local air pollutant.

Table 27 External marginal damage costs per unit of local air pollutant

Costs (€/ ton)	Schwermer	Rabl, Spadaro et al.	Holland, Watkiss	Lechner et al.	Krewitt, Schlomann	Maibach et al.	Holland, Pye et al.
NOx	3,300	2,908	6,800	8,994	3,320	8,700	16,350
fine particulates (PM ₁₀ and PM _{2.5})	11,500	11,723	14,000	6,105	12,000	53,700	44,100 *
CO				262			
NMVOOC	870	1,124	1,400	7,600	870	1,700	3,450

Source: Schwermer (2007), p. 76; Rabl & Spadaro et al. (2005), p. 34; Holland & Watkiss, p.13; data of Lechner et al. quoted from Haas & Kranzl (2002), p. 62; Krewitt & Schlomann (2006), p. 34; Maibach et al. (2007), p. 54; Holland & Pye et al. (2005), p. 14 et. seqq (mean values of provided data); * it has been assumed that marginal damage costs of a mix of PM₁₀ and PM_{2.5} is 5/3 of the mean value of marginal damage costs from pure PM_{2.5}, according to Bickel and Friedrich et al. (2005), p. 14

As shown in Table 27 literature provides a great variety of external marginal damage costs per type of air pollutant.³⁷⁸ It is sometimes argued that uncertainties of marginal damage costs limit their usefulness and therefore their usability. Bickel and Friedrich et al. (2005) counter to this argument that “uncertainties should not purely be looked at by themselves;

³⁷⁴ See Haas, Kranzl (2002), p. 62; Steiner (2006), pp. 70 et seqq.

³⁷⁵ See Haas, Kranzl (2002), p. 61

³⁷⁶ See for instance Bickel, Friedrich (2005)

³⁷⁷ It would go beyond the scope of this study to discuss the whole range of (reduced) external effects due to making the energy system more “green” (find a more comprehensive overview about different kinds of external effects due to energy use for instance in Schwermer, 2007). However, it has to be stated that including externalities from harmful substances the vast part of thinkable externalities is already included. This is true as air pollutants cause damages on human health, which amounts for 70-90 % of overall external damage costs of energy usage (Aunan, Aaheim, Seip, 2000). Furthermore they cause crop losses as well as material damages (see for instance Krewitt & Schlomann, p. 34).

³⁷⁸ See Maibach et al. (2007), p. 128 et seqq. for a more comprehensive overview about literature regarding marginal damage costs of air pollution.

rather one should ask what effect the uncertainties have on the choice of policy options. The key question to be asked is 'how large is the cost penalty if one makes the wrong choice because of errors or uncertainties in the cost or benefit estimates?' In a recent paper Rabl, Spadaro and van der Zwaan (2005) have looked at the uncertainties from this perspective and their findings are very encouraging: the risk of cost penalties is surprisingly small even with the very large uncertainties ...³⁷⁹ They subsequently argue that uncertainties, even if very large, do not matter at binary decisions if they do not change the ranking. For that reason the sensitivity analysis conducted below will analyze whether the lowest as well as the highest values of marginal damage costs provided could change the ranking for different strategies of achieving a certain amount of GHG abatements.

Apart from uncertainties, values for marginal damage costs of air pollutants may highly differ between countries. "Environmental and social externalities are highly site specific and so results will vary widely even within a given country according to the geographic location. Results from the CAFE (Clean Air for Europe Programme) have highlighted that the highest damages are found from emissions in the central parts of Europe and the lowest from countries around the borders of Europe. This reflects variation in exposure of people and crops to the pollutants of interest – emissions at the borders of Europe will affect fewer people than emissions at the centre of Europe, due to the degree of urbanisation and population density."³⁸⁰ For the sake of completeness it has certainly to be added that this argumentation is only correct if damages in non-European bordering countries from European emissions are not accounted for.³⁸¹ Due to the dependence of values of marginal damage costs on geographical parameters, therefore, site specific values are taken for providing decision support for a specific country. In that sense, the analysis is conducted with data of Maibach et al. (2007).³⁸² They do not only provide the most current, but also country and emission-source specific data.

10.6.2 Reduced emissions of natural gas powered cars

Hofbauer et al. (2008) have calculated emissions in harmful air pollutants depending on the different types of engines. It shows up that natural gas powered vehicles (EURO 4) emit less NO_x and fine particulates than the average of a reference fleet of newly registered cars. Regarding to CO and NMVOC however, natural gas powered cars emit more than a reference fleet, as shown in Table 28.

³⁷⁹ Bickel and Friedrich et al. (2005), p. 264

³⁸⁰ European Environment Agency, p. 4

³⁸¹ See European Environment Agency, p.4

³⁸² For CO data of Lechner et al. are taken for this analysis

Table 28 Emissions of harmful air pollutants of different passenger car engines

		NOx	fine particulates	CO	NMVOc
Gasoline	g/km	0.0364	0.0016	0.6555	0.0311
Diesel	g/km	0.5572	0.0210	0.0820	0.0105
average vehicle fleet	g/km	0.3228	0.0123	0.3401	0.0198
Natural Gas	g/km	0.0684	0.0055	0.9821	0.0431
Change in emissions by	%	-78.8	-55.2	+188.8	+118.0

Source: own calculations, emissions data about gasoline, diesel and natural gas powered gas by Hofbauer et al. (2008), p. 128

This surprising result of emissions in CO and NMVOc is contradicting to other information available regarding natural gas powered vehicles.³⁸³ The reasons for that are twofold: Firstly, displayed emission results are not generated by laboratory experiments but rather by “real-world experiments”, thereby using more “realistic” driving cycles than the “New European Driving Cycle”. Secondly, available natural gas powered vehicles are operating with Otto-engines, which are still optimized for gasoline operation.³⁸⁴ However, it is likely that automobile manufacturers will launch respective technologies optimized on operation with natural gas.³⁸⁵ This might lead in the future that displayed emission data will change in favor to natural gas powered engines.

10.6.3 Reduced external costs in considered case studies

In this section, the monetized values of reduced/increased external effects in Austria due to respective activities in analyzed case studies are shown. For that reason, external damage costs per unit of considered air polluting substances are combined with their respective quantities increasingly/decreasingly emitted in Austria due to actions of case studies.

In case study 1 all necessary emission reduction credits are purchased abroad. As no domestic actions are accomplished for generating these credits, no changes in emissions of considered local air pollutants occur in Austria. Therefore, purchasing credits abroad naturally implies that external damage costs of local air pollutant emissions are neither reduced nor increased in Austria.

In case study 2 (and case study 2+) parts of aimed emission reductions (20,000 tons of 100,000 tons) are achieved domestically due to an extension of a respective subsidy scheme. This implies that parts of air pollutant reductions/increases due to considered measures for CO₂-abatement occur also in Austria. Table 29 shows the monetized values

³⁸³ See for instance information at <http://www.erdgasautos.at/umwelt/461> (March 2, 2010) or <http://www.erdgasfahrzeuge.de/fakten-und-gesetze.html> (March 2, 2010). Most certainly, providers of this information are in favor of the natural gas powered vehicle technology. Therefore, those data could be seen as the best case results in reducing harmful air polluting substances by the natural gas powered technology.

³⁸⁴ Expert interview of Johanna Pucker (Joanneum Research, March 2, 2010) who refers to expert information of Hausberger (Technical University of Graz, contributor of respective data and co-author of Hofbauer et al., 2008)

³⁸⁵ Currently (March 2, 2010), one vehicle is launched which is optimized on natural gas operation (expert interview of Johanna Pucker, Joanneum Research, March 2, 2010)

and the corresponding calculating procedure of domestically increased/decreased external effects.

Table 29 *Avoided external damage costs in Austria in the course of GHG-abatements in case study 2/2+*

			NOx	fine particulates	CO	NMVOc
1	Emissions of respective pollutants in sector "MOBIL"	tons (year 2006)	34,000	2,010	61,390	5,700
2	Emissions (of reference fleet) necessary to be covered by domestic GHG-abatement action	tons	58	3	104	10
3	Change in pollutant emissions due to fuel switch	%	-78.8	-55.2	+188.8	+118.0
4	Emissions change (reduction/increase) due to fuel switch	tons	-45.5	-1.9	+197.0	+11.4
5	Emissions change (reduction/ increase) by fuel switch within entire compliance period (8 years)	tons	-364	-15	+1,576	+91
6	External costs of air pollutants	€ per ton	8,700	53,700	262	1,700
7	Reduced/increased external costs of air pollutants	€	-3,170,029	-810,305	+412,990	+155,505
8	SUM of changed external costs	€	-3,411,839			

Source: own calculations, Austrian Federal Environment Agency (data for NOx and fine particulates on line 1)³⁸⁶, Pazdernik et al. (2009)(data for CO and NMVOc in line 1)³⁸⁷

The first row in the table above shows emissions of respective air pollutants within the sector "MOBIL", which represents emissions from the entire current fleet of passenger cars. The second line shows respective emissions of a certain number of conventional cars which are necessary to be replaced by the alternative technology "natural gas car" in order to achieve intended GHG-reductions. According to Annex V this amounts for 0.17 % of air pollutant emissions of the sector "MOBIL". The third line shows once again³⁸⁸ increases/ decreases (in %) of respective air pollutant emissions when applying the natural gas technology instead of the reference technology. Taking data of line two and information of line three leads to information about air pollutant emissions saved/increased due to this fuel switch of 0.17 % of the current fleet of passenger cars, shown in line four. Keeping in mind that air pollutant emissions are saved/increased within an exemplarily assumed (compliance) period of 8 years, overall savings/increases in air pollutant emissions over this period are shown in line

³⁸⁶ Data of NOx:

http://www.umweltbundesamt.at/fileadmin/site/umweltthemen/verkehr/4_auswirkungen/Daten90_07/Nox_90_07_Strassenverkehr.pdf;
last visited May 15, 2010.

Data of fine particulates:

http://www.umweltbundesamt.at/fileadmin/site/umweltthemen/verkehr/4_auswirkungen/Daten90_07/PM07_strasse.pdf;
last visited May 15, 2010.

For the remaining air pollutants CO as well as NMVOc no specification about emissions from passenger cars exists. Therefore an approximation has to be applied: Fractions of emissions in NOx and fine particulates from passenger cars are taken as benchmark (25 %). Therefore it is assumed that passenger cars cause also 25 % of all CO and NMVOc emissions in the transport sector calculated by Pazdernik et al. (2009).

³⁸⁷ Pazdernik et al. (2009), p. 116 (for NMVOc * 25 %), p. 117 (for CO * 25 %)

³⁸⁸ See also Table 28

five. These amounts are valued by respective marginal damage costs of air pollutants discussed in subsection 10.6.1 ("Costs of external effects"). The products of these valuations are shown for each air pollutant in line 7. The sum of these valuations is shown in the last line. This sum shows that domestic actions of case study 2 lead to an increase in welfare of approximately € 3.4 Mio. due to a net-reduction of negative external effects.

The same approach is used for case study 3. In this case study the entire amount of intended GHG-reductions of 100,000 tons is achieved domestically. Not surprisingly, reduced damage costs of harmful local air pollutants affecting domestic welfare are multiple compared to those of case study 2. The result shows that GHG-abating activities in case study 3 reduce external damage costs of local air pollutants by around € 16.9 Mio. within the considered period of eight years (Table 30).

Table 30 *Avoided external damage costs in Austria in the course of GHG-abatements in case study 3*

		NOx	fine particulates	CO	NM VOC	
1	Emissions of respective pollutants in sector "MOBIL"	tons (year 2006)	34,000	2,010	61,390	5,700
2	Emissions (of reference fleet) necessary to be covered by domestic GHG-abatement action	tons	286	17	516	48
3	Change in pollutant emissions due to fuel switch	%	-78.8	-55.2	+188.8	+118.0
4	Emissions change (reduction/increase) due to fuel switch	tons	-225.1	-9.3	+973.6	+56.5
5	Emissions change (reduction/ increase) by fuel switch within entire compliance period (8 years)	tons	-1,800	-75	+7,789	+452
6	External costs of air pollutants	€ per ton	8,700	53,700	262	1,700
7	Reduced/increased external costs of air pollutants	€	-15,663,675	-4,003,858	+2,040,658	+768,378
8	SUM of changed external costs	€	-16,858,497			

Source: own calculations, Austrian Federal Environment Agency (data for NOx and fine particulates on line 1)³⁸⁹, Pazdernik et al. (2009) (data for CO and NMVOC in line 1)³⁹⁰

Conclusion: Not surprisingly, actions in case study 3 cause the highest domestic reduction in local air pollutants and external damage costs respectively. No domestic reductions in air

³⁸⁹ Data of NOx:

http://www.umweltbundesamt.at/fileadmin/site/umweltthemen/verkehr/4_auswirkungen/Daten90_07/Nox_90_07_Strassenverkehr.pdf; last visited May 15, 2010.

Data of fine particulates:

http://www.umweltbundesamt.at/fileadmin/site/umweltthemen/verkehr/4_auswirkungen/Daten90_07/PM07_strasse.pdf; last visited May 15, 2010.

For the remaining air pollutants CO as well as NMVOC no specification about emissions from passenger cars exists. Therefore an approximation has to be applied: Fractions of emissions in NOx and fine particulates from passenger cars are taken as benchmark (25 %). Therefore it is assumed that passenger cars cause also 25 % of all CO and NMVOC emissions in the transport sector calculated by Pazdernik et al. (2009).

³⁹⁰ Pazdernik et al. (2009), p. 116 (for NMVOC * 25 %), p. 117 (for CO * 25 %)

pollutants are achieved by actions of case study 1. However, the extent of results highly depends on assumed damage values of local air pollutants.

10.6.4 Effects of reduced external costs on results

Extending the pure economic assessment of case studies by also including effects on domestic emissions of local and harmful air pollutants provides a more sophisticated decision guidance of different ways for GHG-reductions. Assuming marginal damage costs provided by Maibach et al. (2007), the results are the following as shown in Table 31.

Table 31 Effects of case studies on welfare of consumer at a combined consideration of economic consumer welfare/government welfare and benefits due to locally avoided air pollutants

		Economic consumer welfare	Economic government welfare	Reduced external effects due to domestic reduction of harmful and local air pollutants	Combined consideration
case study 1	Mio. €	-1.7	-3.2	0	-4.9
case study 2	Mio. €	-5.0	-4.5	3.41	-6.1
case study 2+	Mio. €	-1.8	-3.7	3.41	-2.1
case study 3	Mio. €	-2.4	-6.9	16.86	7.6

Source: own calculations based on calculations of sections 10.5 and 10.6

For illustrative reasons, Figure 38 shows these results graphically:

Figure 38 Welfare effects (Mio. €) of analyzed case studies

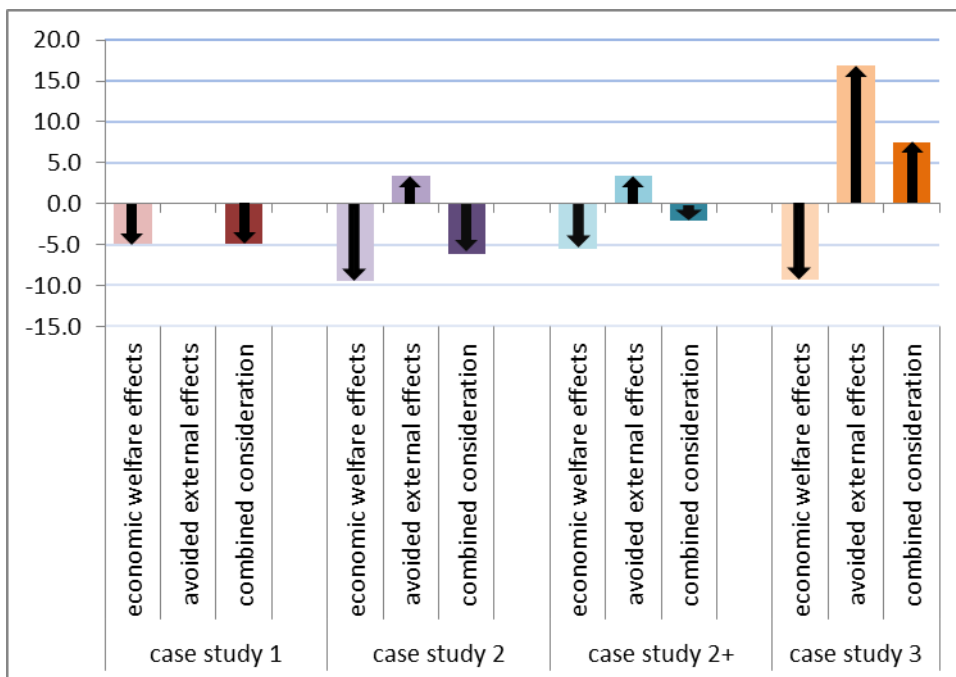

Source: own calculations from case study 1, 2, 2+, 3

Not surprising, from the consumer's point of view the most advantageous way of achieving a certain amount of GHG-reductions is, firstly, where the consumer is only marginally charged for raising funds used to promote mentioned GHG-reductions, and secondly, where high domestic reductions in local and harmful air pollutants can be achieved in connection with GHG-mitigation. This is the case in case study 3, which assumes DOPs as the driver for GHG-reductions. Combining the pure economic welfare effects of this case study with discussed ecological effects leads to an overall positive welfare effect of this strategy for achieving the considered amount of GHG-abatement. Even at slightly higher costs for stimulating GHG-abatements the overall evaluation would not change because of the highly balancing effect of avoided external effects. If the strategy for achieving GHG-abatements assumed for case study 3 is not possible (e.g. due to legal reasons), the second preferable option is still one which achieves GHG-abatements at least partly domestically, and therefore could reduce adverse effects of local air pollution domestically. Inferior to this strategy is entirely offsetting GHG-emissions by purchasing carbon offset certificates from abroad. Only this strategy does not lead to reduce harmful air pollutants domestically. However, entirely purchasing carbon offset certificates from abroad would be still advantageous compared to domestic GHG-abatements if domestic actions could achieve GHG-abatements only with relatively high-cost incentives.

10.7 SENSITIVITY ANALYSIS

A requirement for significant statements regarding economic effects of considered scenarios is their robustness. In order to achieve meaningful statements, results must be valid even if certain values of parameters change. In the following, critical parameters are explained as well as the choice of their values and the effects of changing these values are discussed.

10.7.1 Elasticity of substitution between capital and labor

The elasticity of substitution between capital and labor (MRS_{KL}) tells about the flexibility of companies to change their mix of primary inputs (capital and labor) if new conditions for production arise, i.e. if price relations between these primary inputs change.

In the analysis before, an elasticity of substitution between capital and labor of zero was assumed. In the literature usually values for this elasticity vary from 0 to 1.2.³⁹¹ Now the effects of different values for this elasticity on economic consumer welfare as well as economic government welfare are analysed to see to which extent results change. These effects are displayed in Table 32 for certain values of this elasticity.

Table 32 *Effects of different values for elasticity of substitution between capital and labor on economic consumer welfare and economic government welfare (in Mio. €)*

			$MRS_{KL}=0$	$MRS_{KL}=0.85$	$MRS_{KL}=1.0$	$MRS_{KL}=1.2$
Case study 1	Economic consumer welfare	Mio. €	-1.7	-2.5	-2.7	-2.9
	Economic government welfare	Mio. €	-3.2	-4.5	-4.7	-5.0
	Entire economic welfare	Mio. €	-4.9	-7.0	-7.4	-7.9
Case study 2	Economic consumer welfare	Mio. €	-5.0	-7.0	-7.4	-7.9
	Economic government welfare	Mio. €	-4.5	-7.7	-8.3	-9.1
	Entire economic welfare	Mio. €	-9.5	-14.7	-15.7	-17.0
Case study 2+	Economic consumer welfare	Mio. €	-1.8	-2.5	-2.7	-2.8
	Economic government welfare	Mio. €	-3.7	-5.1	-5.0	-5.4
	Entire economic welfare	Mio. €	-5.5	-7.6	-7.7	-8.2
Case study 3	Economic consumer welfare	Mio. €	-2.4	-2.6	-2.8	-2.6
	Economic government welfare	Mio. €	-6.9	-7.2	-6.9	-7.3
	Entire economic welfare	Mio. €	-9.3	-9.8	-9.7	-9.9

Source: own calculations with adapted version of the ACPI-model

³⁹¹ Kletzan, Steininger, Hochwald (2005), p. 38

Varying the elasticity of substitution between capital and labor leads to changed values for the entire economic welfare in different case studies. However, the ranking of GHG-mitigation strategies based on their entire economic welfare – as done in chapter 10.5 – becomes even more significant at higher values of the analyzed elasticity of substitution.

Combining the economic welfare effects with net reduced external damage cost due to the abatement of local air pollution (ecologic welfare) provides the following combined figures (Table 33).

Table 33 Combined welfare effects (economic and ecologic) for different marginal rates of substitution between capital and labor.

			$MRS_{KL}=0$	$MRS_{KL}=0.85$	$MRS_{KL}=1.0$	$MRS_{KL}=1.2$
Case study 1	Entire economic welfare	Mio. €	-4.9	-7.0	-7.4	-7.9
	Ecologic welfare	Mio. €	0.0	0.0	0.0	0.0
	Combined welfare	Mio. €	-4.9	-7.0	-7.4	-7.9
Case study 2	Entire economic welfare	Mio. €	-9.5	-14.7	-15.7	-17.0
	Ecologic welfare	Mio. €	3.4	3.4	3.4	3.4
	Combined welfare	Mio. €	-6.1	-11.3	-12.3	-13.6
Case study 2+	Entire economic welfare	Mio. €	-5.5	-7.6	-7.7	-8.2
	Ecologic welfare	Mio. €	3.4	3.4	3.4	3.4
	Combined welfare	Mio. €	-2.1	-4.2	-4.3	-4.8
Case study 3	Entire economic welfare	Mio. €	-9.3	-9.8	-9.7	-9.9
	Ecologic welfare	Mio. €	16.9	16.9	16.9	16.9
	Combined welfare	Mio. €	7.6	7.1	7.2	7.0

Source: own calculations based on Table 32 and 10.6.3

It turns out that at combining economic welfare with ecologic welfare the ranking of strategies for achieving a certain amount of GHG-abatement remains the same as stated in chapter 10.6.4. Moreover, the ranking of strategies becomes even more robust at higher values for the analyzed elasticity. At ascending values for this elasticity even lowest values (“worst case approach”) for marginal damage costs of specific local air pollutants (see chapter 10.7.3) do not change the final statements about the superiority of domestically achieved GHG abatements.

10.7.2 Armington elasticities for foreign trade

The Armington elasticities³⁹² are seen in the relevant literature as a crucial element which highly influences results. This is true also for the current analyses.

For testing reasons, simulations have been conducted also with varying values of Armington elasticities, whereby the values of elasticities chosen in the main analysis mark approximately the mean of the respective low and high values. Thereby, Armington elasticities of those sectors have been varied which have shown to be most volatile. These are the sectors CHEMIE (high 0.7/ low 0.35), FAHRZ (1.4/ 0.7) and TEXTIL (1.2/ 0.6). It can be observed from Table 34 and comparing that with Table 35 that imposing rather high values for elasticities leads to a rather high deflection of values for economic consumer/government welfare. This in turn induces that ecologic welfare component becomes less weighty.

Table 34 *Effects of case studies on welfare at imposing high values for Armington elasticities*

		Economic consumer welfare	Economic government welfare	Reduced external effects due to domestic reduction of harmful and local air pollutants	Combined consideration
case study 1	Mio. €	-2.6	-6.3	0	-8.9
case study 2	Mio. €	-5.6	-6.7	3.41	-8.9
case study 2+	Mio. €	-2.9	-7.7	3.41	-7.2
case study 3	Mio. €	-4.7	-15.4	16.86	-3.2

Source: own calculations

Table 35 *Effects of case studies on welfare at imposing low values for Armington elasticities*

		Economic consumer welfare	Economic government welfare	Reduced external effects due to domestic reduction of harmful and local air pollutants	Combined consideration
case study 1	Mio. €	-0.4	-2.3	0	-2.7
case study 2	Mio. €	-3.4	-3.6	3.41	-3.6
case study 2+	Mio. €	-0.4	-2.6	3.41	0.4
case study 3	Mio. €	-2.4	-6.9	16.86	7.6

Source: own calculations

³⁹² Armington elasticities describe the reability of specific sectors in their imports and exports

However, even at varying values of Armington elasticities for most volatile sectors the picture is still pretty clear when considering both economic as well as ecologic welfare effects: The most preferable strategy is to achieve 100,000 tons of CO₂-reduction domestically, thereby also benefiting from the local abatement of harmful air pollution substances. The second best option is to achieve at least a fraction of the 100,000 tons-reduction domestically at low costs.

10.7.3 External damage costs

It has been shown in section 10.6.3 that external damage costs of local air pollutants have considerable impacts on deciding for the best way of achieving intended GHG-reductions. So far, in calculating avoided external damage costs in the course of GHG-abatements country specific data were used which most currently indicate the impacts of geographical conditions on marginal damage costs of air pollutants. However, due to mentioned uncertainties of these values it has to be explored whether varying data provided by literature would change final statements. Therefore, a sensitivity analysis is conducted by applying the analysis with lowest and highest values of marginal abatement costs provided in Table 27. Those data are summarized in Table 36, whereby the lowest values indicate a “best case approach” and highest values indicate a “worst case approach”.

Table 36 *Lowest and highest values of external costs per unit of local air pollutant (€/ ton)*

		Lowest Values (best case approach)	Highest Values (worst case approach)
NO _x	€/ per ton	2,908	16,350
fine particulates (PM ₁₀ and PM _{2.5})	€/ per ton	6,105	53,700
CO	€/ per ton	262	262
NM _{VO} C	€/ per ton	870	7,600

Source: lowest and highest values provided in Table 27

Activities in case study 2 lead to 20,000 tons of domestically carried out GHG-reductions within the assumed period of 8 years. This leads to certain amounts of domestically avoided local air pollutants shown in Table 37. Multiplying these amounts by the lowest as well as highest values for external damage costs per unit of local air pollutant leads to avoided external damage costs of local air pollutants in the course of domestic GHG-abatements both for the “best case approach” and “worst case approach”, shown in the following table.

Table 37 Avoided external damage costs in Austria in the course of GHG-abatements in case study 2/2+ (“best case approach” and “worst case approach”)

		NOx	fine particulates	CO	NM VOC
Emissions change (reduction/ increase) by fuel switch within entire compliance period (8 years)	tons	-364	-15	+1,576	+91
BEST CASE APPROACH					
External costs of air pollutants	€ per ton	2,908	6,105	262	870
Reduced/increased external costs of air pollutants	€	-1,059,591	-92,121	+412,990	+79,582
SUM of changed external costs	€	-659,140			
WORST CASE APPROACH					
External costs of air pollutants	€ per ton	16,350	53,700	262	7,600
Reduced/increased external costs of air pollutants	€	-5,957,469	-810,305	+412,990	+695,199
SUM of changed external costs	€	-5,659,584			

Source: own calculations from data of Table 29 and Table 36

The result for case study 2/2+ shows that the amount of avoided external damage costs of locally abated air pollutants vary considerably when applying lowest and highest external marginal damage costs per unit of air pollutant. The bulk of the change is caused by damage cost changes in NOx.

In case study 3 the entire amount of intended GHG-abatements (100,000 tons) is achieved domestically. This implies that also the entire amount of local air pollutant reductions in the course of the GHG-abatements is achieved domestically. Applying best case data as well as worst case data leads to the following changes in avoided external damage costs of local air pollutants (Table 38).

Table 38 *Avoided external damage costs in Austria in the course of GHG-abatements in case study 3 (“best case approach” and “worst case approach”)*

		NOx	fine particulates	CO	NMVOc
Emissions change (reduction/ increase) by fuel switch within entire compliance period (8 years)	tons	-1,800	-75	+7,789	+452
BEST CASE APPROACH					
External costs of air pollutants	€ per ton	2,908	6,105	262	870
Reduced/increased external costs of air pollutants	€	-5,235,628	-455,187	+2,040,658	+393,229
SUM of changed external costs	€	-3,256,929			
WORST CASE APPROACH					
External costs of air pollutants	€ per ton	16,350	53,700	262	7,600
Reduced/increased external costs of air pollutants	€	-29,436,906	-4,003,858	+2,040,658	+3,435,103
SUM of changed external costs	€	-27,965,004			

Source: own calculations from data of Table 30 and Table 36

Also avoided external damage costs due to domestic GHG abatement actions vary considerably. Once again, the difference is mostly caused by changes in the external price of NOx.

Thus, at a combined consideration of pure economic consumer and government welfare and locally avoided external damage costs due to reduced harmful substances, applying the “best case approach” as well as the “worst case approach” leads to the following results (Table 39 and Table 40):

Table 39 *Effects of case studies on welfare of consumer at a combined consideration of economic consumer welfare/government welfare and benefits due to locally avoided air pollutants at applying the “best case approach”*

		Economic consumer welfare	Economic government welfare	Reduced external effects due to domestic reduction of harmful and local air pollutants	Combined consideration
case study 1	Mio. €	-1.7	-3.2	0	-4.9
case study 2	Mio. €	-5.0	-4.5	0.66	-8.8
case study 2+	Mio. €	-1.8	-3.7	0.66	-4.8
case study 3	Mio. €	-2.4	-6.9	3.26	-6.0

Source: own calculations based on calculations of sections 10.5 and 10.6.1 and 10.7.3

Table 40 Effects of case studies on welfare of consumer at a combined consideration of economic consumer welfare/government welfare and benefits due to locally avoided air pollutants at applying the “worst case approach”

		Economic consumer welfare	Economic government welfare	Reduced external effects due to domestic reduction of harmful and local air pollutants	Combined consideration
case study 1	Mio. €	-1.7	-3.2	0	-4.9
case study 2	Mio. €	-5.0	-4.5	5.66	-3.8
case study 2+	Mio. €	-1.8	-3.7	5.66	0.2
case study 3	Mio. €	-2.4	-6.9	27.97	18.7

Source: own calculations based on calculations of sections 10.5 and 10.6.1 and 10.7.3

Figures of Table 39 and Table 40 show the high impact of the choice of marginal damage costs on final results. At assuming low values of marginal damage costs, least weight is given to reducing local air pollution compared to economic welfare effects. This leads to the outcome for case study 3 that positive effects of local air pollution abatement cannot entirely balance the relatively strong negative impacts on pure economic consumer as well as economic government welfare. Priority is given to strategies of achieving most of GHG abatements abroad (case studies 1 & 2+), whereby the option of achieving remaining GHG abatements (20 %) by high subsidies is still the least preferred one (case study 2). At the alternative treatment, i.e. at putting high weight on locally reduced air pollution, priorities for different strategies are pretty clear: The most preferred option for GHG abatement is this one which also achieves reduction of local air pollution – mostly going along with GHG abatement – entirely domestically. Least priority is given to case study 1 where the entire amount of considered GHG abatements is achieved abroad.

10.7.4 Impacts of “inconveniences”

Although using natural gas powered cars leads to fuel cost savings³⁹³ compared to using conventional cars³⁹⁴, in reality natural gas powered cars are not that favoured as the price advantage would lead to expect. This might be caused by “inconveniences”: little number of service stations selling also natural gas; no long-term experiences with this new technology; potentially worse resale prizes of natural gas powered cars compared to same cars with conventional engines, etc. These inconveniences lead to implicit costs.

The literature does not provide values for these inconveniences so far. However, it is assumed in this analyses that DOP-developers can deal with these inconveniences much better than particular individuals. E.g. DOP-developers might promote the natural gas

³⁹³ However, this might change over time. Furthermore, the price advantage of using natural gas powered cars stems also from the exemption of mineral oil tax on natural gas.

³⁹⁴ See for more details chapter 17 Annex V: Calculation of parameters needed in case studies”

technology only in areas with good access to service stations. Or, DOP-developers might already negotiate for respectable resale prices in exchange for a high quantity of mediated car purchases.

Because of the absence of respective figures in the literature, it is estimated and assumed that holders of natural gas powered cars mediated by DOP-developers face “inconvenience costs” of 5 % of the entire costs for purchasing, operating and maintaining these passenger cars (case study 3). It is further assumed, that holders of natural gas powered cars not mediated by DOP-developers face “inconvenience costs” of 10 % (case study 2/2+).

Table 41 shows how economic welfare varies at different assumptions about “inconvenience costs”. The highlighted values of economic welfare thereby show the values used in the main analysis of chapter 10.5.

Table 41 Effects of different values for “inconvenience costs” on economic welfare (in Mio. €)

			Economic welfare at "inconvenience costs" of ...		
			0%	5%	10%
Case study 1	Economic consumer welfare	Mio. €	-1.7	-1.7	-1.7
	Economic government welfare	Mio. €	-3.2	-3.2	-3.2
	Entire economic welfare	Mio. €	-4.9	-4.9	-4.9
Case study 2	Economic consumer welfare	Mio. €	-4.7	-4.8	-5.0
	Economic government welfare	Mio. €	-4.9	-4.7	-4.5
	Entire economic welfare	Mio. €	-9.6	-9.5	-9.5
Case study 2+	Economic consumer welfare	Mio. €	-1.9	-1.8	-1.8
	Economic government welfare	Mio. €	-4.2	-4.0	-3.7
	Entire economic welfare	Mio. €	-6.1	-5.8	-5.5
Case study 3	Economic consumer welfare	Mio. €	-2.6	-2.4	-2.2
	Economic government welfare	Mio. €	-7.9	-6.9	-5.9
	Entire economic welfare	Mio. €	-10.5	-9.3	-8.1

Source: own calculations with adapted version of the ACPI-model

It turns out from figures shown in Table 41 that highest volatility of values for economic welfare can be observed in case study 3. This is not surprising as the highest amount of natural gas powered cars is introduced in that case study. The ranking of different strategies for achieving GHG-abatements changes only at assuming no inconvenience costs – more specifically, the entire economic welfare loss of case study 2 becomes less than the loss in case study 3. However, values of economic welfare losses change only to a very limited

extent. At applying the approach of combining economic welfare changes with ecologic welfare changes – as conducted in this study – the effects of changing “inconvenience costs” does not change the final statement and final ranking of strategies.

11 Conclusions

Several European countries currently allow Domestic Offset Projects (DOPs) or are in the process of discussing them. Any decision to implement a DOP-scheme in Austria needs to weigh many advantages over many potential disadvantages.

Domestic Offset Projects provide an opportunity to accelerate technology transition towards a more sustainable energy economy without demands on public funds. Furthermore, DOPs use the informational advantage of the 'search engine' capability of private enterprises to stimulate GHG reductions in areas where existing mechanisms are unsatisfactory. This leads also to improved knowledge about potential lacks of incentive policies. Finally, the welfare analysis has shown that achieving GHG-abatements domestically, through a mechanism that results in very low consumer expense (i.e. finding least expensive abatement options) is more advantageous than purchasing carbon offset certificates from abroad or achieving domestic GHG-abatements only through high-cost incentives.

However, DOP-schemes may have disadvantages, in particular for achieving internationally agreed climate protection targets in the short-run. The most serious drawbacks are the risk of potential non-additionality of individual DOPs and likely competition for low-cost domestic GHG abatement measures ("low-hanging fruits") between the government and the private sector. Other concerns include potentially high transaction costs or low-abatement potential actuated by DOP-schemes.

Appropriate design provisions can be used to address most of the potential disadvantages of DOP schemes. Doubts regarding a possibly low GHG-abatement potential cannot, however, be dispelled as abatement potential cannot be estimated ex-ante and will highly depend on the design of a DOP-scheme. Generally, for boosting this potential – and also for lowering transaction costs – a programmatic approach for DOPs should be chosen. The potential of DOPs could also be increased through a minor use of governmental subsidies. However, using public funds for promoting DOPs based on Joint Implementation (JI) would lead to the unfortunate outcome that achieved GHG-abatements would not be available for assisting national efforts to achieve short-run emission targets. Taking into account that the current crediting period ends in 2012, introducing a DOP-scheme based on JI is therefore not advisable. The time-consuming introduction of individual projects and rather marginal amounts of GHG-abatements achievable up to 2012 lead to insignificant contributions to Kyoto-targets. Rather, preparatory work should be undertaken to enable introduction of a DOP-scheme in 2013 embedded into a European or international (post-2012) framework. Article 24a of the amended Directive 2003/87/EC³⁹⁵ provides the legal basis ensuring that preparatory efforts would not be in vain even if no appropriate international agreement exists after 2012. Furthermore, the Voluntary Carbon Offset Market should be fostered – first mainly by stimulating demand for Voluntary Carbon Offset credits, but also subsequently by

³⁹⁵ European Parliament legislative resolution of 17 December 2008 on the proposal for a directive of the European Parliament and of the Council amending Directive 2003/87/EC so as to improve and extend the greenhouse gas emission allowance trading system of the Community.

stimulating supply. Advantages of this are straightforward: it provides useful experiences for a post-2012 DOP-scheme embedded into a European or international framework and contributes to answering outstanding questions about the GHG-abatement potential via DOPs and whether low-price incentives are sufficient for raising GHG-abatement when using the potential of the search-engine capability of the private market.

12 FAQs

What is additionality?

Projects accomplished to generate carbon offset credits have to demonstrate that they would not have been carried out in the absence of additional incentives provided by the carbon market, i.e. that their implementation would be additional to business as usual. This might be demonstrated by additionality tests. These include the analysis about financial and non-financial barriers for carrying out projects, identify common practice and the consistency with mandatory laws and regulations.

How strict are additionality requirements for DOPs?

All discussed DOP-schemes require additionality of projects – generally and without exception. However, even strict additionality tests bear the risk that certain non-additional projects cannot be filtered out. To this end, some of the discussed DOP design options include provisions to protect against non-additionality. These provisions are, for example, discounting of allocated AAUs/ERUs by the government or siphoning off a share of private investors' profits to compensate the government for certain non-additional projects.

Which GHG abatement potential could be raised by DOPs?

The GHG abatement potential that can be raised by DOPs cannot be quantified ex-ante and with certainty. Only the “searching engine” market can give ultimate information about this. However, the achievable abatement potential of DOPs can be considerably influenced by designing favorable framework conditions.

Could there be competition for cheap potential between government and developers of DOPs?

Without appropriate provisions there could arise competition for cheap GHG abatement potential between the government and developers of DOPs. To ensure that no “run” for cheap projects starts, the government could also select project-types to which DOPs should not be applied.

Could DOPs simultaneously apply for governmental subsidies?

In general, simultaneously claiming both governmental subsidies and revenues from DOP-credits' sales could be approved if additionality is still guaranteed. However, in that case, the government would provide subsidies for GHG abatements which could not be added to the government's efforts to meet its short and medium term climate protection targets, i.e. would not lower the emissions gap. Although, it should be mentioned that prohibiting simultaneous application for governmental subsidies of DOPs would certainly reduce the GHG abatement potential that can be raised by DOPs. However, the economic analyses have shown that

combining DOPs with high governmental subsidies might have worse impacts on the consumer welfare.

13 ANNEX I: Relevant environmental subsidies in Austria

This chapter provides an overview of subsidies for GHG abatement actions in Austria. The overview makes no claim to be complete but shows the most important subsidies for promoting climate friendly behavior. It is mainly based on Sattler, Lang, Lutter (2005) but also on information provided by the respective subsidy schemes. Environmental subsidies are displayed separately depending on the granting authorities. As environmental subsidies of federal states could substantially differ among federal states they are also shown for each state separately.

Examined areas for subsidies are the buildings sector, renewable energy, energy efficiency, agriculture and forestry, industry and other business as well as transport.

13.1.1 Environmental subsidies in Austria in the area of buildings construction and reconstruction

This section shows subsidies in the area of buildings construction and reconstruction for each Austrian federal state. It should be emphasized, that buildings are defined here as objects for living and hosting offices. Subsidies for buildings used only for commercial purposes are considered in the subsidy scheme “Umweltförderung im Inland”.

Federal state of Burgenland

- State governmental subsidized loan for all kinds of houses for reconstruction
- Subsidy for single-family houses for reconstruction dependent on certain conditions like improvements of thermal insulation or other energy savings
- Non-repayable subsidy for alternative energy facilities and facilities to reduce energy consumption in the residential sector
- Non-repayable subsidy for the construction of heating facilities (biomass, heat pump, solar, photovoltaics, etc.) in commercial buildings
- In general:
 - Basic subsidy for building reconstruction does not include Kyoto-relevant criteria beyond legal efficiency obligations
 - Additional subsidies for “special” reconstruction activities like special thermal restoration, usage of alternative energy resources, usage of ecologic building materials

Federal state of Carinthia

- Subsidy for building reconstruction (e.g. thermal insulation, connection to heat distribution networks, usage of sustainable energies)
- Subsidies for commercial buildings to install electricity heaters

- In general:
 - No incentives for Kyoto-relevant building construction beyond legal efficiency obligations

Federal state of Lower Austria

- Subsidy for building reconstruction (e.g. thermal insulation, connection to heat distribution networks, solar energy heating), condition: max. 50 kWh/m²a
- Increase of subsidy for building reconstruction depending at certain energy saving characteristics
- Subsidy for commercial buildings also for Kyoto-relevant investments (e.g. installation of non-fossil fuel using heating facilities and energy savings at the same time)
- In general:
 - SINGLE-FAMILY HOUSES: Incentive for energy saving after building reconstruction; differences in subsidy intensity dependent on certain conditions
 - MULTIPLE-FAMILY HOUSES: Incentive for energy saving after building reconstruction

Federal state of Upper Austria

- Subsidy for buildings reconstruction, e.g. replacement of fossil heating system, connection to heat distribution networks, etc., subsidy varies between multiple- and single family houses
 - Basic subsidy for building reconstruction does not include Kyoto-relevant criteria beyond legal efficiency obligations
 - Increased subsidy for Kyoto-relevant reconstruction

Federal state of Salzburg

- Subsidy for energy saving investments of small and medium companies, also for technical and ecological improvements of small-scale hydro-power
- Subsidy for multiple-family house and flats for reconstruction
- Special subsidy for energy saving activities, usage of sustainable energy resources, ecologic construction method
- In general:
 - Basic subsidy for building reconstruction includes certain Kyoto-relevant minimum standards
 - Increased subsidy for more extensive Kyoto-relevant reconstruction

Federal state of Styria

- Repayable subsidy for energy saving activities via building reconstruction for multiple-family buildings and flats

- Repayable subsidy for single-family house only if also thermal insulation is accomplished
- Increase of subsidy dependent of certain energy saving activities (e.g. biomass- or solar heater, heat pump, photovoltaics)
- In general:
 - Basic subsidy for building reconstruction does not include Kyoto-relevant criteria beyond legal efficiency obligations
 - Increased subsidy for more extensive Kyoto-relevant reconstruction

Federal state of Tyrol

- Subsidy for substitution of an existing heating installation by biomass heater
- Subsidy for reconstruction of multiple-family buildings under consideration of minimum insulation standards
- Subsidy for solar energy facilities
- Subsidy for sustainable heating systems (e.g. biomass heating, heat pump)
- In general:
 - Basic subsidy for building reconstruction includes certain Kyoto-relevant minimum standards
 - Increased subsidy for more extensive Kyoto-relevant reconstruction

Federal state of Vorarlberg

- Subsidy for building reconstruction for all kinds of houses
- In general:
 - Basic subsidy for building reconstruction includes certain Kyoto-relevant minimum standards
 - Increased subsidy for more extensive Kyoto-relevant reconstruction

Federal state of Vienna

- Subsidy for improvement of thermal insulation of windows
- Subsidy for building reconstruction (e.g. thermal insulation, heat insulated windows, connection to central heating facilities) in multiple-family houses single-family houses and flats
- In general:
 - Basic subsidy for building reconstruction does not include Kyoto-relevant criteria beyond legal efficiency obligations

- Increased subsidy for more extensive Kyoto-relevant reconstruction

13.1.2 Environmental subsidies in Austria in the area of renewable energy

This section gives an overview of subsidies by particular Austrian federal states in the area of renewable energy

Federal state of Burgenland

- Subsidy for the construction of alternative energy heaters in sports facilities

Federal state of Carinthia

- Subsidy of wood fired heating facilities in single-,double- and multiple family houses (also mirco-networks)
- Subsidy for thermal solar plants
- Subsidy for heat pumps
- Subsidy for construction of and connection to local heating plants

Federal state of Lower Austria

- Subsidy of biomass district heating systems
- Subsidy for energy generated by biomass and other sustainable alternatives (biomass heating facilities, biogas facilities, small-scale hydro power plants, small-scale biomass district heating plants including distribution networks, facilities for generation of biofuels, solar and photovoltaic facilities, heat pumps)

Federal state of Upper Austria

- Subsidy for construction of sustainable energy generation facilities (heat pumps, solar plants, connection to district and local heating plants, biogas facilities)
- Subsidy for construction of solid biomass combustion plants, also for district and local heating
- Subsidy for construction and reconstruction of small-scale hydro power plants
- Subsidy for facilities of space heat recovery
- Subsidy for photovoltaic plants and wind power plants

Federal state of Salzburg

- Prefinancing of district heating connection
- Subsidy for installation of biomass heating facilities
- Subsidy for installation of biogas facilities, small-scale hydro power plants, biofuel refineries

- Subsidy for installation of wood fired central-heating, and for local- and district heating connections
- Subsidy for installation of solar plants and heat pumps
- Subsidy for installation of solar plants in sports facilities

Federal state of Styria

- Subsidy for construction of biomass local heat facilities (incl. combined heat and power generation – CHP)
- Subsidy for construction of biogas facilities and local heating centers/ micro heat distribution networks run by farmers or farmers consortia
- Subsidy for construction of wood chips and pellets combustion plants
- Subsidy for construction of renewable energy generation plants

Federal state of Tyrol

- Subsidy for construction of biomass facilities (e.g. wood chips, biogas) for heating, CHP and electricity generation
- Subsidy for installation of heat pumps, solar plants, space heat recovery

Federal state of Vorarlberg

- Subsidy for installation of biomass central heating facilities (e.g. pellets, wood chips)
- Subsidy for installation of biogas plants run by farmers or farmers' consortia
- Subsidy for installation of local heating plants, photovoltaic and solar power plants, heat pumps
- Subsidy for installation of solar power plants in sports facilities

Federal state of Vienna

- Subsidy for installation of biomass heating facilities, heat pumps and thermal solar plants

Overview

Table 42 Overview of subsidies in the area of renewable energy by federal states of Austria

	Biomass single heating	Biomass local heating (incl. Connection to local heating distribution network)	Heat pump	Solar heating	Sustainable energy usage at sports facilities	Kyoto-relevant subsidies by "Wirtschaftsförderung "	Green electricity from biomass	Geothermic facilities	Small-scale hydro power	Wind power	Photovoltaic power
Burgenland											
Carinthia											
Lower Austria							Biogas				
Upper Austria											
Salzburg											
Styria											
Tyrol											
Vorarlberg											
Vienna											

Source: Sattler et al. (2005), p. 92

13.1.3 Environmental Subsidies in Austria in the area of efficient energy usage

This section shows environmental subsidies in the federal states of Austria in the area of efficient energy usage.

Federal state of Burgenland

- Financing of energy efficient electrical equipment for customers of provincial electricity provider BEWAG

Federal state of Carinthia

- Interest free loan for energy certain efficient equipment (e.g. heat pumps, space heat recovery facilities, electric heating)

Federal state of Lower Austria

- Subsidy for energy costs lowering activities of communities
- Subsidy for energy efficient electrical equipment for customers of provincial energy provider EVN
- Loans for change to natural gas heating

- Subsidy for change of old central-heating boiler and connection to district heating network

Federal state of Upper Austria

- Subsidy for energy saving activities for provincial energy provider “Energie AG” customers
- Subsidy for substitution of other fossil fuel heaters by natural gas heaters, exchange of old central-heating boilers, and combination of natural gas heaters with solar power facilities for customers of the provincial natural gas provider “Erdgas Oberösterreich”
- Subsidy for thermal restoration

Federal state of Salzburg

- Subsidy for exchange of fossil fuel fired heaters and connection to district heat networks

Federal state of Tyrol

- Subsidy for change to natural gas using facilities for customers of provincial energy provider TIWAG
- Subsidy for connection to district- or local heating networks
- Subsidy for industrial heat recovery

Federal state of Vienna

- Subsidy for installation of gas fired heating
- Subsidy for connection to district heating plants

13.1.4 Environmental subsidies in Austria in the area of agriculture and forestry

The subsidizing environment in the area of agriculture and forestry is mainly based on funding of the European Union (European Regional Development Fund – EFDF) and co-funding of the federal government. In Austria the granting authorities for these funds are often the chambers of agriculture in particular federal states.

13.1.5 Environmental subsidies in Austria in the area of industry and business

Environmental subsidies for industrial facilities and other business are mainly thought as promotion tool for commercial activities. Savings in greenhouse gases (GHG) are in most cases side effects. In the following, only those subsidies and promoting activities will be listed, which are relevant in terms of GHG savings and which are granted by the federal states. Environmental grants for the commercial sector by the federal government, most important the so-called “Umweltförderung im Inland” will be considered in section 13.1.7.

Federal state of Burgenland

- Subsidy for activities of commercial environment protection (“Wirtschaftsförderung – focal point environment and ecology)
- Subsidy for modernization of touristic accommodation facilities (among others e.g. installation of biomass or biogas heating facilities, solar and wind power plants, heat pumps)

Federal state of Carinthia

- Subsidy for investments in thermal restorations of walls in touristic accommodation facilities

Federal state of Lower Austria

- Subsidy for investment of the introduction of non-fossil energy
- Subsidy for modernization and efficient usage of energy for small and medium touristic facilities

Federal state of Upper Austria

- Subsidy for investments of companies essential for local supply (e.g. food markets)

Federal state of Salzburg

- Subsidy for investments in buildings for modernization of commercial buildings

Federal state of Styria

- Subsidy for investments of touristic facilities (e.g. in energy saving activities, usage of sustainable energy)

Federal state of Tyrol

- Subsidy for energy saving activities of small-sized companies
- Subsidy for thermal restoration and installation of thermal solar plants of small-scale and private owned touristic accommodation facilities

Federal state of Vorarlberg

- Subsidy for investments in modernization of small- and medium sized businesses
- Subsidy for modernization of touristic infrastructure

13.1.6 Environmental subsidies in Austria in the area of transport

In the area of transport the subsidy environment is rather moderate. High environmental relevance in the area of transport might be the subsidies for the public transport.

Furthermore, the federal government subsidizes relevant measures in the transport sector by the “Umweltförderung im Inland” mentioned in the subsequent section.

Some companies as well as federal states subsidize the conversion from conventional transport systems to natural gas or electricity powered mobility.

13.1.7 Environmental Subsidies in Austria only granted by the federal government

The most powerful instruments for promoting energy efficiency and energy savings in Austria are the so-called “Umweltförderung im Inland (UFI)” and the “Ökostromförderung”, both granted by the federal government. The first of those subsidizes specific projects in the area of energy efficiency and savings, the latter is a feed in tariff to promote and accelerate the diffusion of sustainable electricity production from renewables.

***Umweltförderung im Inland (UFI)*³⁹⁶**

The subsidy scheme “Umweltförderung im Inland” supports different areas to mitigate greenhouse gas emissions. In contrast to many other subsidies, this kind of subsidy aims to support commercial facilities in their effort for energy savings and efficiency. Furthermore, the UFI is co-financed by the European Regional Development Fund³⁹⁷. As a general requirement, the UFI supports GHG abating activities with a maximum of 30 per cent of total investment costs. This subsidy scheme is restricted to:

- Companies to fulfill their commercial activities
- Confessional facilities and non-profit associations
- Public owned facilities which act as companies with market based activities
- Energy supplying companies
- The UFI will not support natural or legal persons, who are supported already by other supporting frameworks
- Application for financial support has to be submitted before project start.

This subsidy scheme supports activities in the areas “renewable energy”, “energy efficiency” as well as “transport”:

- Renewable energy
 - Biomass heating systems
 - Biomass fired combined heat and power (CHP)
 - Biomass fired district heating
 - Solar heating
 - Connection to district heating networks

³⁹⁶ More detailed information is available at http://www.publicconsulting.at/kpc/de/home/umweltforderung/fr_betriebe/ . (May 6, 2010)

³⁹⁷ Sattler et al. (2005), p. 79

- Energy recovery from biogenic resources and waste materials
- Geothermal energy
- Production of biogenic combustibles and fuels
- Electricity (from renewable energy sources) producing facilities without connection to the public grid
- Heat distribution networks

- Energy efficiency
 - Energy efficiency in building appliances
 - Energy efficiency in production processes
 - Energy efficiency – waste heat recovery
 - Heat pumps
 - Fossil fired combined heat and power (CHP)
 - Thermal insulation
 - Low energy houses
 - Environmental friendly cooling and air conditioning

- Transport
 - Measures for environmental more friendly transport in companies
 - Petrol stations for alternative fuels
 - Mobility management activities (klima:aktiv mobil)
 - E-Mobility and mobility powered by alternative fuels

Ökostromförderung (feed-in tariff)

Austria introduced also a feed-in tariff to enable electricity production by renewable sources. This feed-in tariff is subject to frequent amendments. However, applying DOPs to electricity generation would lead to the double counting problem (see chapter 5.2.3). Therefore, subsidies for projects potentially leading to double counting when carried out as DOPs is therefore in this context beyond the scope of interest.

13.1.8 Other environmental subsidies and schemes to stimulate environmental-friendly behavior on the base of the Austrian state of Styria

Other environmental subsidies or incentives to stimulate environmental-friendly behavior are:

- Klima-Energie-Fonds (Climate-Energy-Fund)
- Klima:Aktiv

- Zukunft-Innovations-Fund (Future-innovation funds)
- Steirische Wirtschaftsförderung (Styrian economy promotion funds)
- Ökofonds Steiermark

14 ANNEX II: Ability for MRV of greenhouse gases in different sectors

The reliability of GHG emission reductions always depends on the possibility to monitor, report and verify (MRV) these emission reductions. Therefore – separated by particular sectors – the (un)certainty for GHG emission estimates and the complexity of a corresponding MRV procedure has to be examined. The analysis is based on the outcomes of Handley, Bates, Phylipsen, Gilbert (2006) and Wartmann, Harnisch, Phylipsen, Gilbert (2006).

The following tables show different emission sources listed by particular sectors. Thereby, uncertainty in emissions (measurement) is stated, which is an essential base for a proper MRV procedure. Also the number and size of emitters is an important detail to know, as it is a crucial factor whether certain emissions should be covered by potential DOP or better by other market-based or non-market-based instruments. In the end, also a first qualitative assessment about the complexity of getting specific emissions data and verifying these data is shown. The procedures of monitoring and verifying can be considerable complex also because of a large, hardly manageable number of emitters. However, this work is specifically focused on the issue of how to stimulate GHG emission reductions precisely for such a large number of emitters.

14.1.1 Agriculture and forestry

Table 43 GHG Emissions of the sector “agriculture and forestry” for potential coverage under a Domestic Offset Project scheme

Sub-Sector	GHG	Source	Uncertainty in emissions	Number and size of emitters (in EU)	Feasibility for MRV
Agriculture	CO ₂	Combustion of fuels	Medium / low	very large number / small emitters	Complex/poor method for data collection, medium complex method for verification
Agriculture	CH ₄	Enteric fermentation	High	large number / small to large emitters	Complex/poor method for data collection and verification
Agriculture	CH ₄	Manure management	High	large number / small to large emitters	Complex/poor method for data collection and verification
Agricultural soils	N ₂ O	Application of mineral nitrogenous fertilizers and organic fertilizers	High	large number / varying size	Complex/poor method for data collection and verification
Agriculture	N ₂ O	Manure management	High	large number / varying size	Complex/poor method for data collection and verification

Source: Handley et al. (2006), Wartmann et al.(2006)

14.1.2 Households and offices

Table 44 GHG Emissions of the sector “households and offices” for potential coverage under a Domestic Offset Project scheme

Sub-Sector	GHG	Source	Uncertainty in emissions	Number and size of emitters (in EU)	Feasibility for MRV
Households	CO2	Space heating / warm water / cooking	Medium / low	very large number / small emitters	Complex/poor method for data collection and verification
Offices	CO2	Space heating / warm water	Medium / low	very large number / small emitters	Complex/poor method for data collection and verification
Refrigeration and air conditioning	HFC	Predominantly leakage from cooling systems during operation and servicing	high	large number / diverse sources	Complex/poor method for data collection and verification
Refrigeration and air conditioning	PFC	Predominantly leakage from cooling systems during operation and servicing	High	large number / diverse sources	Complex/poor method for data collection and verification

Source: Handley et al. (2006), Wartmann et al.(2006)

14.1.3 Transport

Table 45 GHG Emissions of the sector “transport” for potential coverage under a Domestic Offset Project scheme

Sub-Sector	GHG	Source	Uncertainty in emissions	Number and size of emitters (in EU)	Feasibility for MRV
Road transport	CO2	Fuel combustion	Low	Very large number / small emitters	Complex/poor method for data collection and verification
Railways	CO2	Fuel combustion	Low		Complex/poor method for data collection and verification
Transport	CH4	Transport fuel combustion	High	Very large number / small emitters	Complex/poor method for data collection and verification
Transport	N2O	Fuel combustion in all kinds of transport	High	Very large number / small emitters	Complex/poor method for data collection and verification

Source: Handley et al. (2006), Wartmann et al.(2006)

14.1.4 Waste

Table 46 GHG Emissions of the sector “waste” for potential coverage under a Domestic Offset Project scheme

Sub-Sector	GHG	Source	Uncertainty in emissions	Number and size of emitters (in EU)	Feasibility for MRV
Waste incineration	CO2	Combustion processes	Medium / high	average number / average emitters	Not complex/good method for data collection and verification
Waste management	CH4	Waste disposal on land	High	average number / large emitters	Not complex/good method for data collection and verification
Waste water	CH4	Waste water handling	High	large number / varying size	Medium complex/restricted method for data collection and verification
Waste water	N2O	Waste water handling	High	large number / varying size	Medium complex/restricted method for data collection and verification

Source: Handley et al. (2006), Wartmann et al.(2006)

14.1.5 Industry not covered by the EU-ETS

Table 47 GHG Emissions of the sector “industry not covered by the EU-ETS” for potential coverage under a Domestic Offset Project scheme

Sub-Sector	GHG	Source	Uncertainty in emissions	Number and size of emitters (in EU)	Feasibility for MRV
Fuel-production	CO2	Onshore - oil and gas - flaring (installations < 20 MW)	Medium / high		Medium complex/restricted method for data collection and verification
Ferrous metals	CO2	Foundries, rolling and others not covered in Phase I+II	Low	average number / large emitters	Medium complex/restricted method for data collection and verification
Non-ferrous metals	CO2	primary aluminium (installations <20 MW)	Low	large number / small to average emitters	Not complex/good method for data collection and verification
Non-ferrous metals	CO2	Other	Low	small number / average emitters	
Non-metalic minerals	CO2	Gypsum	Low	small number / small emitters	Not complex/good method for data collection and verification
Non-metalic minerals	CO2	Rock wool	Low	small number / average emitters	Not complex/good method for data collection and verification
Chemicals	CO2	Petro-chemicals (at combustion processes installations < 20MW)	Medium / high	small number / large emitters	Not complex/good method for data collection and verification
Chemicals	CO2	Other chemicals (at combustion processes installations < 20MW)	Medium	large number / small to large emitters	Not complex/good method for data collection and verification
Secondary manufacturing	CO2	Food / drink products	Low	large number / small to medium emitters	Complex/poor method for data collection, restricted possibility for verification

Sub-Sector	GHG	Source	Uncertainty in emissions	Number and size of emitters (in EU)	Feasibility for MRV
Secondary manufacturing	CO2	Textiles / leather	Low	large number / small emitters	Complex/poor method for data collection, medium complex/restricted method for verification
Secondary manufacturing	CO2	Wood products	Low	large number / small emitters	Complex/poor method for data collection, medium complex/restricted method for verification
Secondary manufacturing	CO2	Plastic / rubber production	Low	large number / small emitters	Complex/poor method for data collection, medium complex/restricted method for verification
Secondary manufacturing	CO2	Transport equipment machinery	Low	large number / small to medium emitters	Complex/poor method for data collection, medium complex/restricted method for verification
Chemicals	N2O	Nitric acid manufacture	Low	small number	Not complex/good method for data collection and verification. Continuous monitoring or spot sampling. Measurement standard of N2O emissions has to be developed
Manufacturing	N2O	Fuel combustion	Medium / low	large number	Medium complex/restricted method for data collection and verification
Aluminium production	PFC	Released when normal operating conditions are disturbed	Low	small number	Not complex/good method for data collection and verification. This sector is already regulated, so additional MRV may not add significant extra costs
Manufacturing	PFC	Semiconductor consumption	Low	small number / large emitters	Not complex/good method for data collection and verification
Manufacturing	SF6	Semiconductor consumption - emitted during use for etching and cleaning of semiconductors	Low	limited number (also in Austria ?)	Not complex/good method for data collection and verification

Source: Handley et al. (2006), Wartmann et al.(2006)

14.1.6 Power plants not covered by the EU-ETS and energy distribution

Table 48 GHG Emissions of the sector “power plants not covered by the EU-ETS and energy distribution” for potential coverage under a Domestic Offset Project scheme

Sub-Sector	GHG	Source	Uncertainty in emissions	Number and size of emitters (in EU)	Feasibility for MRV
Fugitive emissions	CH4	Leakage of natural gas distribution systems (fugitive emissions)	Medium		Medium complex/restricted method for data collection and verification. Monitoring is straight forward to compared to fugitive leaks
Fuel combustion	CH4	Fuel combustion from energy use	High	very large number / small emitters	Medium complex/restricted method for data collection , complex/poor method for verification
Fuel combustion	N2O	Fuel combustion in power stations	Medium / low	small to medium number	Not complex/good method for data collection and verification
Electrical Equipment	SF6	Used to insulate high voltage switchgear. Emissions mostly from leakage	Low	large number / small sources	Complex/poor method for data collection and verification

Source: Handley et al. (2006), Wartmann et al.(2006)

15 ANNEX III: Specification of emitting sources

Table 49 Greenhouse gas sources of emission category **energy** (category 1)

A. Fuel Combustion Activities		
1.A.1 Energy industries	a. Public Electricity and Heat Production b. Petroleum Refining c. Manufacture of Solid Fuels and Other Energy Industries	
1.A.2 Manufacturing Industries and Construction	a. Iron and Steel b. Non-Ferrous Metals c. Chemicals d. Pulp, Paper and Print e. Food Processing, Beverages and Tobacco f. Other	Mineral industry Construction Mining Other non-specified
1.A.3 Transport	a. Civil Aviation b. Road Transportation c. Railways d. Navigation e. Other Transportation	Off-road vehicles and other machinery
1.A.4 Other Sectors	a. Commercial/Institutional b. Residential c. Agriculture/Forestry/Fisheries	
1.A.5 Other (Not specified elsewhere)	a. Stationary b. Mobile	Lubricants Military use
B. Fugitive Emissions from Fuels		
1.B.1 Solid Fuels	a. Coal Mining and Handling b. Solid Fuel Transformation c. Other	Decommissioned Mines
1.B.2 Oil and Natural Gas	a. Oil b. Natural Gas c. Venting and Flaring d. Other	Other non-specified

Source: own illustration based on UNFCCC³⁹⁸

³⁹⁸ http://unfccc.int/national_reports/annex_i_ghg_inventories/national_inventories_submissions/items/4771.php ; January 13, 2010

Table 50 Greenhouse gas sources of emission category *industrial processes* (category 2)

A. Mineral Products	
2.A.1 Cement Production 2.A.2 Lime Production 2.A.3 Limestone and Dolomite Use 2.A.4 Soda Ash Production and Use 2.A.5 Asphalt Roofing 2.A.6 Road Raving with Asphalt 2.A.7 Other	a. Glas Production b. Magnesia Production c. Other non-specified
B. Chemical Industry	
2.B.1 Ammonia Production 2.B.2 Nitric Acid Production 2.B.3 Adipic Acid Production 2.B.4 Carbide Production 2.B.5 Other	a. Carbon Black b. Ethylene c. Dichloroethylene d. Styrene e. Methanol f. Other non-specified g. Synthetic Rutile and Titanium Dioxide h. Polymers and other chemicals i. Acetylene Use
C. Metal Production	
2.C.1 Iron and Steel Production 2.C.2 Ferroalloys Production 2.C.3 Aluminium Production 2.C.4 SF6 Used in Aluminium and Magnesium Foundries 2.C.5 Other	a. Other non-specified
D. Other Production	
2.D.1 Pulp and Paper 2.D.2 Food and Drink	
E. Production of Halocarbons and SF6	
2.E.1 By-product Emissions 2.E.2 Fugitive Emissions 2.E.3 Other	a. Production of HCFC-22 b. Other c. Other non-specified
F. Consumption of Halocarbons and SF6	
2.F.1 Refrigeration and Air Conditioning Equipment 2.F.2 Foam Blowing 2.F.3 Fire Extinguishers 2.F.4 Aerosols/ Metered Dose Inhalers 2.F.5 Solvents 2.F.6 Other applications using ODS substitutes 2.F.7 Semiconductor Manufacture 2.F.8 Electrical Equipment 2.F.9 Other	a. Other non-specified

G. Other	
2.G.1 Other	a. Other non-specified b. Confidential emissions reported as CO2-e

Source: own illustration based on UNFCCC³⁹⁹

Table 51 Greenhouse gas sources of emission category *solvent and other product use* (category 3)

A. Paint Application	
B. Degreasing and Dry Cleaning	
C. Chemical Products, Manufacture and Processing	
D. Other	
3.D.1 Use of N2O for Anaesthesia 3.D.2 N2O from Fire Extinguishers 3.D.3 N2O from Aerosol Cans 3.D.4 Other Use of N2O 3.D.5 Other	a. Other non-specified b. Consumer cleaning products c. Aerosols

Source: own illustration based on UNFCCC⁴⁰⁰

Table 52 Greenhouse gas sources of emission category *agriculture* (category 4)

A. Enteric Fermentation	
4.A.1 Cattle	a. Dairy Cattle b. Non-Dairy Cattle
4.A.2 Buffalo	
4.A.3 Sheep	
4.A.4 Goats	
4.A.5 Camels and Llamas	
4.A.6 Horses	
4.A.7 Mules and Asses	
4.A.8 Swine	
4.A.9 Poultry	
4.A.10 Other	a. Deer b. Alpacas c. Ostriches/Emus d. Non-Dairy Cattle - Feedlot

³⁹⁹ http://unfccc.int/national_reports/annex_i_ghg_inventories/national_inventories_submissions/items/4771.php ; January 13, 2010

⁴⁰⁰ http://unfccc.int/national_reports/annex_i_ghg_inventories/national_inventories_submissions/items/4771.php ; January 13, 2010

B. Manure Management

4.B.1 Cattle	a. Dairy Cattle b. Non-Dairy Cattle
4.B.2 Buffalo	
4.B.3 Sheep	
4.B.4 Goats	
4.B.5 Camels and Llamas	
4.B.6 Horses	
4.B.7 Mules and Asses	
4.B.8 Swine	
4.B.9 Poultry	
4.B.10 Other Livestock	
4.B.11 Anaerobic Lagoons	
4.B.12 Liquid Systems	
4.B.13 Solid Storage and Dry Lot	
4.B.14 Other AWMS	

C. Rice Cultivation

4.C.1 Irrigated	a. Other non-specified
4.C.2 Rainfed	
4.C.3 Deep Water	
4.C.4 Other	

D. Agricultural Soils

4.D.1 Direct Soil Emissions	
4.D.2 Pasture, Range and Paddock Manure	
4.D.3 Indirect Emissions	
4.D.4 Other	

E. Prescribed Burning of Savannas

F. Field Burning of Agricultural Residues

4.F.1 Cereals	a. Other non-specified b. Peanuts
4.F.1 Pulses	
4.F.1 Tubers and Roots	
4.F.1 Sugar Cane	
4.F.1 Other	

G. Other

Source: own illustration based on UNFCCC⁴⁰¹

⁴⁰¹ http://unfccc.int/national_reports/annex_i_ghg_inventories/national_inventories_submissions/items/4771.php ; January 13, 2010

Table 53 Greenhouse gas sources of emission category *LULUCF* (category 5)

A. Total Forest Land	
5.A.1 Forest Land remaining Forest Land 5.A.2 Land converted to Forest Land	a. Cropland converted to Forest Land b. Grassland converted to Forest Land c. Wetlands converted to Forest Land d. Settlements converted to Forest Land e. Other Land converted to Forest Land
B. Total Cropland	
5.B.1 Cropland remaining Cropland 5.B.2 Land converted to Cropland	a. Forest Land converted to Cropland b. Grassland converted to Cropland c. Wetlands converted to Cropland d. Settlements converted to Cropland e. Other Land converted to Cropland
C. Total Grassland	
5.C.1 Grassland remaining Grassland 5.C.2 Land converted to Grassland	a. Forest Land converted to Grassland b. Cropland converted to Grassland c. Wetlands converted to Grassland d. Settlements converted to Grassland e. Other Land converted to Grassland
D. Total Wetlands	
5.D.1 Wetlands remaining Wetlands 5.D.2 Land converted to Wetlands	a. Forest Land converted to Wetlands b. Cropland converted to Wetlands c. Grassland converted to Wetlands d. Settlements converted to Wetlands e. Other Land converted to Wetlands
E. Total Settlements	
5.E.1 Settlements remaining Settlements 5.E.2 Land converted to Settlements	a. Forest Land converted to Settlements b. Cropland converted to Settlements c. Grassland converted to Settlements d. Wetlands converted to Settlements e. Other Land converted to Settlements
F. Total Other Land	
5.F.1 Other Land remaining Other Land 5.F.2 Land converted to Other Land	a. Forest Land converted to Other Land b. Cropland converted to Other Land c. Grassland converted to Other Land d. Wetlands converted to Other Land e. Settlements converted to Other Land

Source: own illustration based on UNFCCC⁴⁰²

⁴⁰² http://unfccc.int/national_reports/annex_i_ghg_inventories/national_inventories_submissions/items/4771.php ; January 13, 2010

Table 54 Greenhouse gas sources of emission category *waste* (category 6)

A. Solid Waste Disposal on Land	
6.A.1 Managed Waste Disposal on Land	
6.A.2 Unmanaged Waste Disposal Sites	a. Deep (> 5m) b. Shallow (< 5m)
6.A.3 Other	a. Other non-specified
B. Waste Water Handling	
6.B.1 Industrial Waste Water	a. Waste Water b. Sludge
6.B.2 Domestic and Commercial Waste Water	a. Waste Water b. Sludge
6.B.3 Other	a. Waste Water b. Sludge
C. Waste Incineration	
6.C.1 Biogenic Waste Incineration	
6.C.2 Other Waste Incineration	a. Solvents b. Other non-specified c. Clinical Waste Incineration d. Municipal Waste Incineration
D. Other	
6.D.1 Other non-specified	

Source: own illustration based on UNFCCC⁴⁰³

⁴⁰³ http://unfccc.int/national_reports/annex_i_ghg_inventories/national_inventories_submissions/items/4771.php ; January 13, 2010

16 ANNEX IV: Illustrative DOP examples from other countries

In the following illustrative examples for DOPs from other countries are described. It has to be emphasized that these examples for DOPs could be implemented in other countries under regard to specific framework conditions in these countries. This does not mean, however, that exactly these project-types could also be implemented in Austria, as framework conditions may differ considerably.

16.1 FRANCE

Examples for JI projects in France are **fuel switches** as for example switches of fossil fired heating systems to biomass fired ones in office buildings. An additional example is the use of other, more climate friendly **cooling liquids** for refrigerators in supermarkets. Also projects to reduce N₂O can be accomplished as DOPs in France. An example for that is the **thermal oxidation of gaseous effluents** of the Trifluoroacetic Acid generating station at the Salindres factory (Gard). A further example is the **additional reduction in the N₂O emissions in gaseous effluents from the Adipic Acid production** installation at the Chalampe plant (Haut-Rhin).⁴⁰⁴

16.2 GERMANY

Domestic JI projects in Germany can be distinguished between two characteristics: On the one hand they focus on project types (energy efficiency, fuel switches) where many small-scale emitters – households or small enterprises – are pooled by a programmatic approach. On the other side they focus on project types where specific and new technologies should be implemented, mostly N₂O abatement.⁴⁰⁵

One example of energy efficiency and fuel switch projects is the project **JIM.NRW**, initiated by the energy agency of North Rhine-Westfalia and implemented in 2008.⁴⁰⁶ This project focuses on the **replacement of old heating and steam boilers** (< 20 MW), thereby leading to CO₂ reductions due to higher energy efficiency and fuel switches.⁴⁰⁷ As each particular CO₂ mitigation activity would not achieve emission reductions high enough to cover administration costs (MRV) the JIM.NRW combines many small-scale measures to a programmatic project. The energy agency of North Rhine-Westfalia is responsible for that achieved emission reductions get converted into tradable CO₂-certificates and sells them on

⁴⁰⁴ See also http://ji.unfccc.int/JI_Projects/ProjectInfo.html ; January 20, 2010

⁴⁰⁵ See also http://ji.unfccc.int/JI_Projects/ProjectInfo.html or http://www.netinform.de/KE/Wegweiser/Ebene1_Projekte.aspx?Ebene1_ID=50&mode=5 ; January 20, 2010

⁴⁰⁶ See also <http://www.energieagentur.nrw.de/Emissionshandel/page.asp?TopCatID=10653&CatID=6358&RubrikID=6358> ; January 19, 2010

⁴⁰⁷ See also <http://www.energieagentur.nrw.de/Emissionshandel/page.asp?TopCatID=10653&CatID=6358&RubrikID=6358> ; January 20, 2010

the emissions trading market. The duration of this project is five years (2008-2012). Potential participants can join this project anytime.

Similar to that is the also programmatic project **Pro.Jlm**.⁴⁰⁸ It also focuses on CO₂ reductions due to higher energy efficiency and fuel switches due to **replacement of boilers**. Participating agents are only enterprises which are customers of the “Proenergy contracting”.

Also the **Imtech energy efficiency programme**⁴⁰⁹ focuses on the replacement of boilers as well as the replacement of installations for exhaust gas treatment in small and medium enterprises. The administrative procedure is similar to the projects mentioned before. The project lasts from 2009 to 2012.

The “**Bayerngas Ökobonusprogramm Gewerbe- und Industriekunden**”⁴¹⁰ focuses on the conversion of old heating boilers and steam boilers to new and more efficient natural gas fired boilers. The focused clientele are business customers. It also builds up on a programmatic approach; the administrative procedure is similar to the aforementioned projects.

Also for achieving higher customer retention the RWE Westfalen-Weser-Ems AG has initiated the programmatic JI project **RWE Climate Bonus Project Heat Pumps**. It focuses on the early conversion of “existing heating systems (from fuel oil, coal, liquid gas and natural gas) to electric powered heat pumps as well as the installation of state-of-the-art electric powered heat pumps in new buildings.”⁴¹¹ The climate bonus should provide necessary incentives for conversion existing heating systems even within their expected life time.

There are many other and similar projects focusing on higher energy efficiency and (partly) fuel switches.⁴¹² The second focus is laid on projects to reduce N₂O emissions. Additionality of this project type is justified due to the lack of corresponding directives and the absence of appropriate incentives to implement N₂O abatement technologies. Project examples for that are for instance the **YARA Rostock N₂O abatement projects**.⁴¹³ Via a new catalyze technique 85 % of N₂O emissions in the production process of nitric acid can be saved. Similar to that are the following projects:⁴¹⁴

- Catalytic reduction of nitrous oxide emissions (N₂O) from the nitric acid plant of SKW Stickstoffwerke Piesteritz
- Redundant thermal decomposition of residual nitrous oxide (N₂O) from the LANXESS adipic acid production in Krefeld-Uerdingen
- Redundant catalytic decomposition of residual nitrous oxide (N₂O) from the BASF adipic acid plant in Ludwigshafen

⁴⁰⁸ See also http://www.proenergy.de/ihre_energie/pro_jim.asp ; January 20, 2010

⁴⁰⁹ See also http://www.imtech.de/imtech_subdomains/imtech-contracting/leistungen/leistungen.php?option=leistung_energy_efficiency ; January 20, 2010

⁴¹⁰ See also http://www.bayerngas.de/data/07_dialog/bonus.html ; January 20, 2010

⁴¹¹ http://www.transferstelle-emissionshandel-hessen.de/mm/FutureCamp_Projektblatt_RWE_Webformat_engl.pdf ; January 20, 2010

⁴¹² See for instance http://www.netinform.de/KE/Wegweiser/Ebene1_Projekte.aspx?Ebene1_ID=50&mode=5 ; January 20, 2010

⁴¹³ See http://www.netinform.de/KE/files/pdf/Yara%20Rostock%202.01%20PDD%20090213%20CGB_GSC_.pdf ; January 20, 2010

⁴¹⁴ See http://www.netinform.de/KE/Wegweiser/Ebene1_Projekte.aspx?Ebene1_ID=50&mode=5 ; January 20, 2010

- Catalytic reduction of N₂O inside the Ammonia Burners of the BASF Nitric Acid Plant in Ludwigshafen
- Catalytic reduction of N₂O inside the ammonia burner and catalytic N₂O destruction in the tail gas of the Bayer Nitric Acid Plant in Köln-Worringen

In addition to that Germany hosts Domestic JI projects where mine gas (methane) is separated and flared, as for instance the ***mine gas flaring at shaft Nordschacht***.⁴¹⁵

16.3 THE NETHERLANDS

The implementation of DOP in the Netherlands is still in the process of discussion. The Foundation Joint Implementation Network has proposed for instance DOPs related to biogas.

⁴¹⁵ See http://www.netinform.de/KE/files/pdf/Yara%20Rostock%202.01%20PDD%20090213%20CGB__GSC_.pdf; January 20, 2010

17 Annex V: Calculation of parameters needed in case studies

For estimating economic effects of considered case studies certain parameters have to be calculated. In the following the calculation of these parameters is shown in order to ensure traceability.

In 2009 the fleet of diesel and gasoline powered passenger cars amount for around 4,354,300 cars.⁴¹⁶ From the entire fleet around **55 %** is powered by **diesel** and **45 %** is powered by **gasoline**. This distribution of the current fleet is also similar to the latest survey of newly registered diesel and gasoline powered passenger cars.⁴¹⁷

Generally valid estimations of fuel costs savings of natural gas powered cars compared to conventional cars are difficult, as prices and price differences change daily. The following data were used to apply a method for calculating fuel cost savings due to natural gas powered cars:

Table 55 Data for calculating fuel costs savings of natural gas powered cars compared to conventional cars

	Amount of fuel with same energy content	Costs/ unit	Costs at same energy content	Specific fuel consumption	Weighted fuel costs at same energy content
Natural gas	1 kg	0.8912 €/kg	0.8912 €	0.736 (kWh/km)	0.6559 €
Diesel	1.3 litre	1.059 €/l	1.5067 €	0.621 (kWh/km)	0.9357 €
Gasoline	1.5 litre	1.156 €/l	1,7340 €	0.708 (kWh/km)	1.2277 €

Source (ordered by column): (1) www.erdgasautos.at⁴¹⁸, (2) ÖAMTC⁴¹⁹, (2) Austrian Federal Ministry for Economy, (3) & (5) own calculations, (4) Hofbauer et al. (2008)⁴²⁰

The energy content of one kilogram of natural gas (CNG) is equivalent to approximately 1.3 litres of diesel or 1.5 litres of gasoline. Amounts of these fuels with equivalent energy content were multiplied by their respective unit prices, leading to costs of fuels with the same energy content. However, the differently powered engines have different specific fuel consumptions, i.e. they use fuels with different efficiency. It shows up that natural gas powered cars use fuel with a slightly lower efficiency than diesel and gasoline powered cars (EURO 4)⁴²¹. Therefore,

⁴¹⁶ Data of Statistics Austria, http://www.statistik.at/web_de/statistiken/verkehr/strasse/kraftfahrzeuge_-_bestand/index.html, Kfz-Bestand 2009, Table 1; May 13, 2010

⁴¹⁷ Compare Pötscher (2009), p. 19

⁴¹⁸ http://www.erdgasautos.at/user_pdfs/CNG2_kern_low.pdf, p.5; May 13, 2010

⁴¹⁹ ÖAMTC (Austrian Automobile Association),

<http://www.oemtc.at/sprit/?state=&fuelType=9&daysLimit=1&ZIP=&spritaction=doSimpleSearch&search=Anzeigen>; May 13, 2010

⁴²⁰ Hofbauer et al. (2008), p. 128

⁴²¹ Hofbauer et al. (2008) have also provided data of emission category EURO 6. However, these data were not generated by measurements but only by projections from current data. Therefore subsequent calculations base on EURO 4 as their values can be verified by on-road tests.

the costs of fuels containing the same energy are weighted according to these efficiencies. The thereby generated weighted fuel costs are used now for calculating fuel cost savings: Applying the distribution of the current fleet of conventional cars (55 % diesel, 45 % gasoline) the weighted fuel costs of mobility with the conventional fleet is € 1.0671⁴²² compared to mobility with natural gas with € 0.6559 (see Table 55). This implies **fuel cost savings of 38.5 %**⁴²³. Although this cost saving opportunity⁴²⁴, in reality however, natural gas powered cars are not that favoured. This might be caused by inconveniences: little number of service stations selling also natural gas; no long-term experiences with this new technology; potentially worse resale prizes of natural gas powered cars compared to same cars with conventional engines, etc. These inconveniences lead to implicit costs. Therefore, it is assumed that irrational acting individuals value the natural gas technology as 10 %⁴²⁵ more costly because of mentioned inconveniences.⁴²⁶ However, certain groups being better informed about opportunities, advantages and disadvantages of the natural gas technology might not value inconveniences that high – for this group only 5 % of costs are added.⁴²⁷

Beside fuel cost savings also potential savings of greenhouse gases due to applying the natural gas technology is an essential parameter in the examining model. Hofbauer et al. (2008) has examined different powering technologies of cars according to their emissions in greenhouse gases and other pollutants:

Table 56 Vehicle data for passenger cars

Combustion engine (EURO 4)	Specific fuel consumption	Greenhouse gas emissions			
		CO ₂	CH ₄	N ₂ O	CO ₂ e
		[g/km]	[g/km]	[g/km]	[g/km]
Natural gas	0.736	147.9096	0.0398	0.0033	149.8997
Diesel	0.621	155.72051	0.0002	0.0056	157.3909
Gasoline	0.708	183.8303	0.0019	0.0018	184.4068

Source: Hofbauer et al. (2008), p. 128; own calculations inter alia by applying GEMIS-Österreich (2008) V4.5

Based on data of specific fuel consumptions and on specific GHG-emissions of fuels⁴²⁸ CO₂-emission of fuels were calculated. Also, emissions of CH₄ and N₂O should also be

⁴²² € 0.9357 (weighted fuel costs of diesel) * 0.55 (fraction of diesel powered cars) + € 1.2277 (weighted fuel costs of diesel) * 0.45 (fraction of gasoline powered cars)

⁴²³ Calculations with data of EURO 6 would lead to fuel cost savings of 42.6 % (calculations based on data of Hofbauer et al. (2008))

⁴²⁴ For the sake of completeness it has to be added that the magnitude of cost savings might not be valid in the long run. Currently, alternative fuels are promoted by tax reliefs, e.g. no petroleum tax is imposed on natural gas. This is seen as one instrument to promote a fuel switch from conventional fuel types to alternative ones. However, in the long run when consumption of alternative fuels reaches a certain level, tax reliefs might be abolished in order to not incur tax deficits.

⁴²⁵ Thereby not taking fuel cost savings into account

⁴²⁶ This additional charge of 10 % is applied in case study 2

⁴²⁷ This additional charge of 5 % is applied in case study 3

⁴²⁸ Natural Gas: 200.953 g/kWh; Diesel: 250.832 g/kWh (268.269 g/kWh minus 6.5 % of biodiesel added); Gasoline: 259.746 g/kWh (268.888 g/kWh minus 3.4 % bioethanol added); information based on GEMIS-Österreich (2008) V 4.5 and G. Jungmeier (Joanneum Research)

considered as their global warming potentials (GWP)⁴²⁹ are considerably higher than of CO₂. Taking into consideration all three major greenhouse gases does not change CO₂e-emissions of all three types of engines considerably. Weighting CO₂e-emissions of diesel and gasoline according to the distribution of the current fleet, conventional new cars are responsible for 169.83 g CO₂e/km on average.⁴³⁰ Compared to CO₂e-emissions of natural gas powered cars, the natural gas technology emits for the same service **11.7 %**⁴³¹ **less CO₂e-emissions.**

At the policy simulation of **case study 2, 20,000 tons of CO₂e** should be saved domestically within an assumed compliance period, taking 8 years for example.⁴³² This amount of CO₂e-savings should be achieved by further stimulating the purchase of natural gas powered passenger cars instead of conventional cars. It is assumed in case study 2 that this would be achieved by increasing funds available in the specific funding focus⁴³³ of the “Austrian environmental support on the operational level” (UFI), thereby granting the same subsidy rate of **19.0 %**⁴³⁴ as in the time period 2002-2004. Furthermore, it is assumed that all investments are done at the beginning of the compliance period⁴³⁵ in order that aimed CO₂e abatements can be achieved by an only little number of natural gas powered passenger cars.⁴³⁶ In order to achieve an (additional) domestic CO₂e reduction of 20,000 tons over the entire compliance period of 8 years, each year 20,000/8 = 2,500 tons have additionally to be reduced by the subsidy scheme. These 2,500 tons should be saved by newly registering natural gas powered passenger cars instead of other fossil fuel powered cars. As the new technology emits 11.7 % less CO₂ then the average of conventional technologies, conventional technologies currently representing **21,370 tons**⁴³⁷ **of CO₂e emissions have to be substituted** by the new technology “natural gas powered cars”. The emitting source “passenger cars” has been responsible for CO₂e emissions of 12,786,000 tons⁴³⁸. This means, in order to achieve necessary CO₂-reductions (2,500 tons), the additional subsidizing activity by the government has to stimulate an additional **switch of 0.17 %**⁴³⁹ to the natural gas powered technology.

In the next policy simulation – **case study 3 – 100,000 tons of CO₂**⁴⁴⁰ should be saved domestically within an assumed compliance period of 8 years. It is – once again – assumed

⁴²⁹ GWP of CO₂: 1; GWP of CH₄: 25; GWP of N₂O: 298; information: G. Jungmeier (Joanneum Research)

⁴³⁰ 157.8997 gCO₂e/km * 55 % + 184.4068 gCO₂e/km * 45 % = 169.8279 gCO₂e/km

⁴³¹ Comparing technologies at emission category EURO 6, CO₂e abatements of 17.4 % would be possible (calculations based on data of Hofbauer et al. (2008))

⁴³² This compliance period is determined exemplarily. However, a potential application period for DOPs could be the period 2013-2020 (8 years).

⁴³³ According to information of the Kommunalkredit Public Consulting (Kommunalkredit Public Consulting, [3] 2009, p. 22) the amount of GHG mitigation measures already approved for funding far exceed the amount available for funding.

⁴³⁴ Karner, A., Kletzan, D., Kraner, H., Harather, K. [2] (2008), p. 97

⁴³⁵ This is assumed for calculating purposes. In reality (additional !) investments could also be done before the compliance period, however, saved GHGs could only be considered starting with the compliance period.

⁴³⁶ The necessity of achieving CO₂ abatements by a rather small fleet of natural gas powered vehicles is justified by the assumption, that finding people/companies willing to participate to that project causes (information/ transaction) costs – they are higher at big fleets build up over years than small fleets. Furthermore, by trend this assumption leads to lower economic effects of domestic actions.

⁴³⁷ 21,370 (tons) = 2,500 (tons) * 100 (%) / 11.7 (%)

⁴³⁸ Fact sheet of Austrian Federal Environmental Agency;

http://www.umweltbundesamt.at/fileadmin/site/umweltthemen/verkehr/4_auswirkungen/Daten90_07/Treibhausgasemissionen_1990_-_2007_Verkehrssektor.pdf; data of 2006 in order to be compatible with economic data available; May 13, 2010.

⁴³⁹ 21,370 tons / 12,786,000 tons

⁴⁴⁰ From the amount of 100,000 tons it is assumed that 80,000 tons belong to the representative installation, whereas 20,000 tons belong to the government, assuming a discount rate of 20 % (compare Option 3: DOP-scheme based on Domestic JI with discounting of allocated ERUs ; chapter 9.3)

that all investments are done at the beginning of the compliance period to ensure that the necessary number of involved vehicles is as low as possible. The necessary CO₂-abatement is achieved by DOPs initiated by the representative iron and steel producing installation. The GHG-abatement is promoted by funding provided by the mentioned representative installation, which in turn receives thereby generated carbon offset certificates. Provided funding by the representative installation has to be definitely lower or equal than costs of buying CO₂ certificates abroad equivalent to 80,000 tons of CO₂-reductions (case study 1). It is therefore assumed that the representative installation is able to achieved expected GHG-abatements even by a much lower “subsidy rate” due to its informational advantage (“search engine market”). Achieving 100,000 tons of CO₂ reductions over a period of 8 years, each year 12,500 tons⁴⁴¹ of CO₂ has to be abated. Taking the abovementioned CO₂e-savings achievable by natural gas powered cars compared to diesel and gasoline powered cars, conventional technologies of currently representing **106,840 tons⁴⁴² of CO₂ emissions have to be substituted**. This amount represents **0.84 %** of 12,786,000 tons annually emitted by the passenger cars.

⁴⁴¹ 100,000 tons / 8 years = 12,500 tons

⁴⁴² 106,840 tons = 12,500 tons * 100 (%) / 11.7 (%)

18 Annex VI: GHG saving potentials: sectors and quantities

A crucial question when discussing about new incentives for stimulating further GHG-abatements is the question about the GHG-abatement potential domestically available. This topic about the magnitude of GHG-abatement potential is object of controversial discussions and different viewpoints.

The subsequent information about potential for climate protection is based on relevant literature. The most comprehensive and up to date one is from Eichhammer et al. (2009) which describes in detail energy saving potentials in all EU-member states for all relevant sectors. They provide three different scenarios of saving potentials for each of the years 2010, 2015, 2020, 2025 and 2030. These saving potentials are estimated based on a low policy intensity scenario (LPI)⁴⁴³, a high policy intensity scenario (HPI)⁴⁴⁴ and a technical scenario⁴⁴⁵ – all of them are in comparison to an autonomous scenario. The estimated saving potential is based on an underlying database published at www.eepotential.eu.⁴⁴⁶ Further relevant literature in this respect is from Sattler and Adensam et al. (2008) which describes potential for energy efficiency in Austria. Steininger et al. (2007) lay the focus on climate protection options and their potential in the transport sector. Kletzan-Slamanig et al. (2008) elaborate the energy saving potential in the housing sector. The following description about the GHG saving potential in specific sectors gives a rough and comparable overview about the estimated GHG-saving potential in each sector.

18.1 AGGREGATE OF END-USE SECTORS

Austria's total potential to save end-use of energy are illustrated in the next figure and sorted by scenario for the years 2005-2030. It becomes clear in this illustration, that even a low-policy intensity scenario (LPI) might achieve considerable savings in end-use energy. It can be observed that the potentials to save rise steadily over the period viewed.

⁴⁴³ The LPI scenario „implies continued high barriers to energy efficiency, a low policy effort to overcome the barriers and high discount rates for investments in energy efficiency“. (Eichhammer et al., 2009, p. 40).

⁴⁴⁴ The HPI scenario „implies removing barriers to energy efficiency, a high policy effort to overcome the barriers and low discount rates for investments in energy efficiency, options are economic on a life cycle basis“. (Eichhammer et al., 2009, p. 40).

⁴⁴⁵ The technical scenario „includes also more expensive but still fairly realistic options; no exotic technologies“. (Eichhammer et al., 2009, p. 40).

⁴⁴⁶ See Eichhammer et al. (2009): p. 293

Figure 39 Total potential to save end-use of energy in Austria

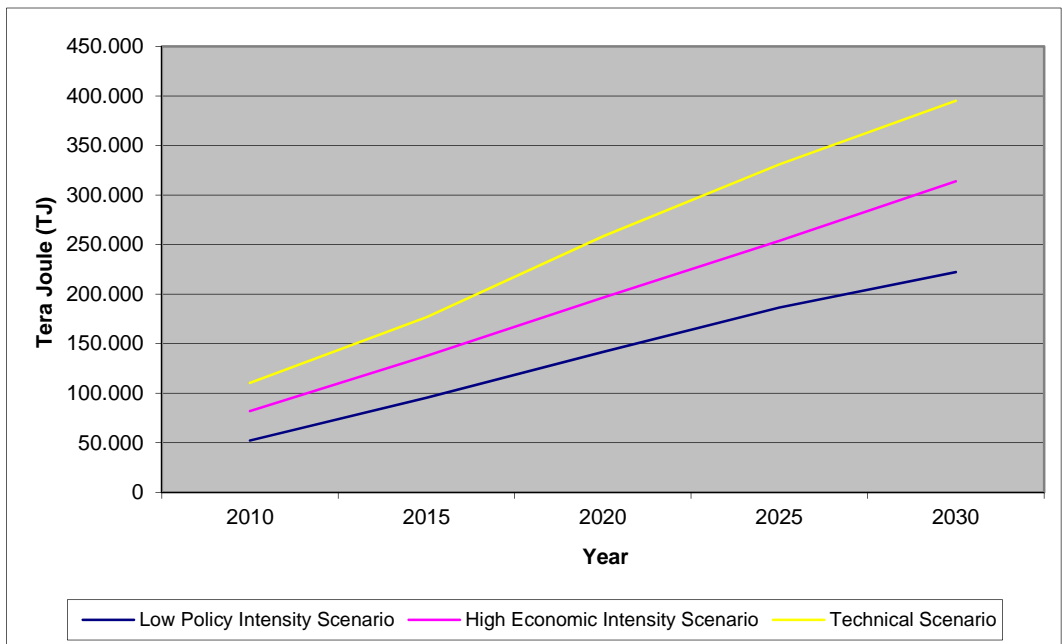

Source: own illustration, data based on www.eepotential.eu

Going a little bit more into detail, it can be observed that – in general – potential to decrease end-use of energy is mostly located in the area of fuel savings rather than electricity savings.

Figure 40 Total potential to save end-use of energy in Austria, splitted by fuel savings and electricity savings

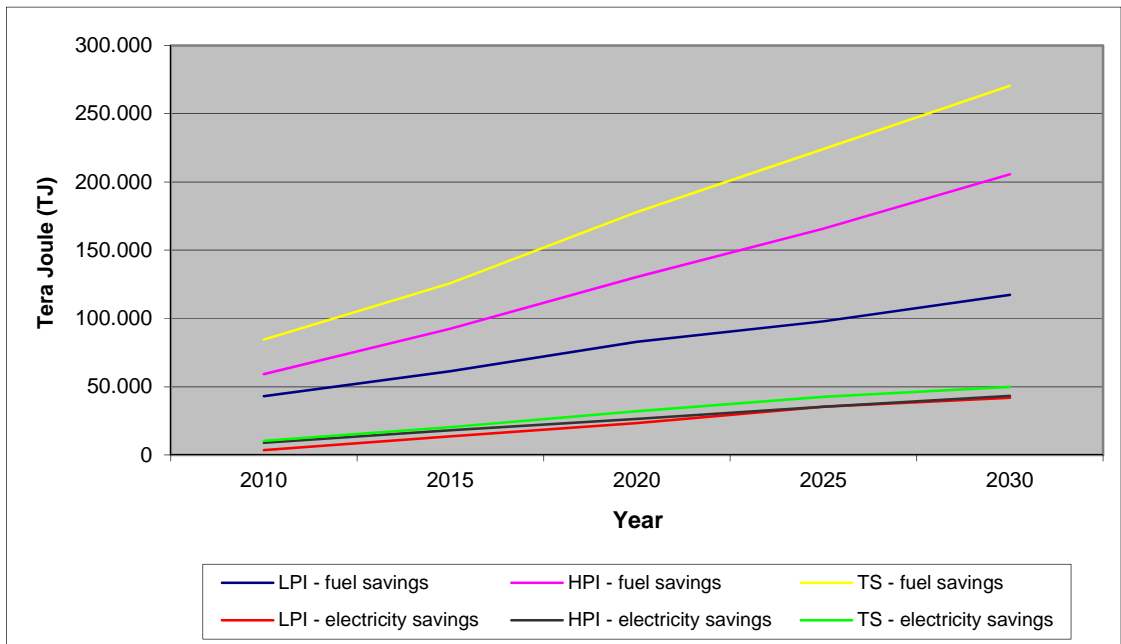

Source: own illustration, data based on www.eepotential.eu

18.2 HOUSEHOLDS

The bulk of energy savings in households can be achieved by actions for fuel savings. The figure below shows this in detail: More ambitious policies could achieve energy savings as multiple as low policy intensities.

Figure 41 Fuel saving potential in households (Austria)

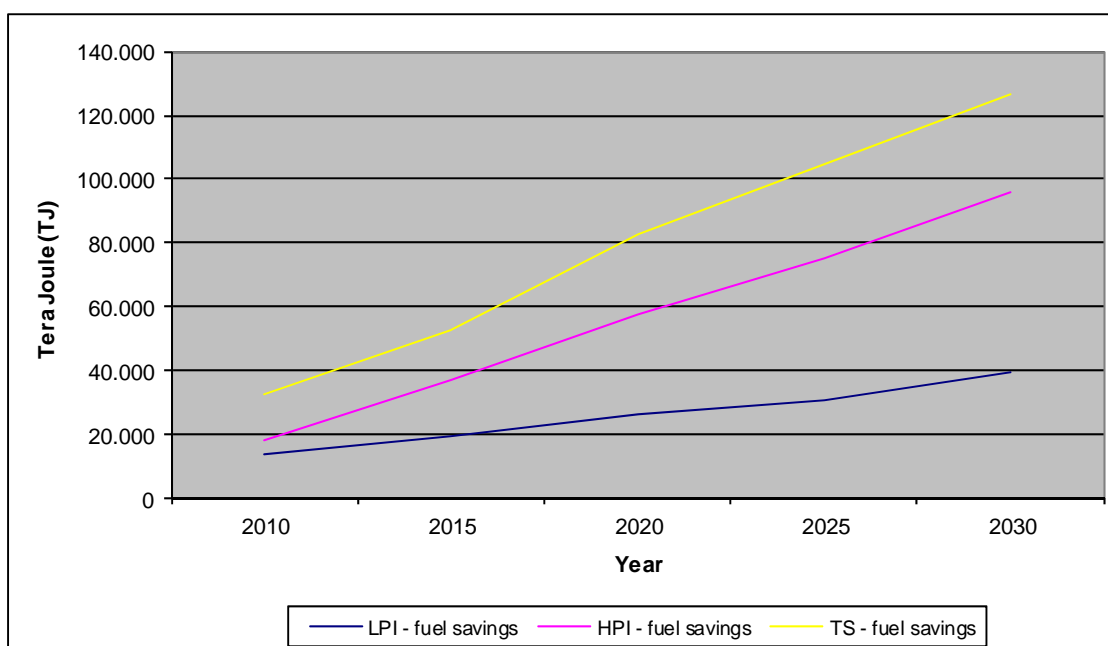

Source: own illustration, data based on www.eepotential.eu

According to Kletzan-Slamanig et al. (2008) the highest saving potential could be raised at refurbishing buildings constructed between 1961 and 1980.⁴⁴⁷ They suggest that focus is laid on single family as well as semi-detached houses.

On the other side, the potential for electricity savings is relatively low compare to the potential for fuel savings. The highest potential can be seen at lighting as well as technical appliances as TV, laundry dryer, refrigerators and computers.

⁴⁴⁷ Compare Kletzan-Slamanig et al. (2008), p. 19

Figure 42 Electricity saving potential in households (Austria)

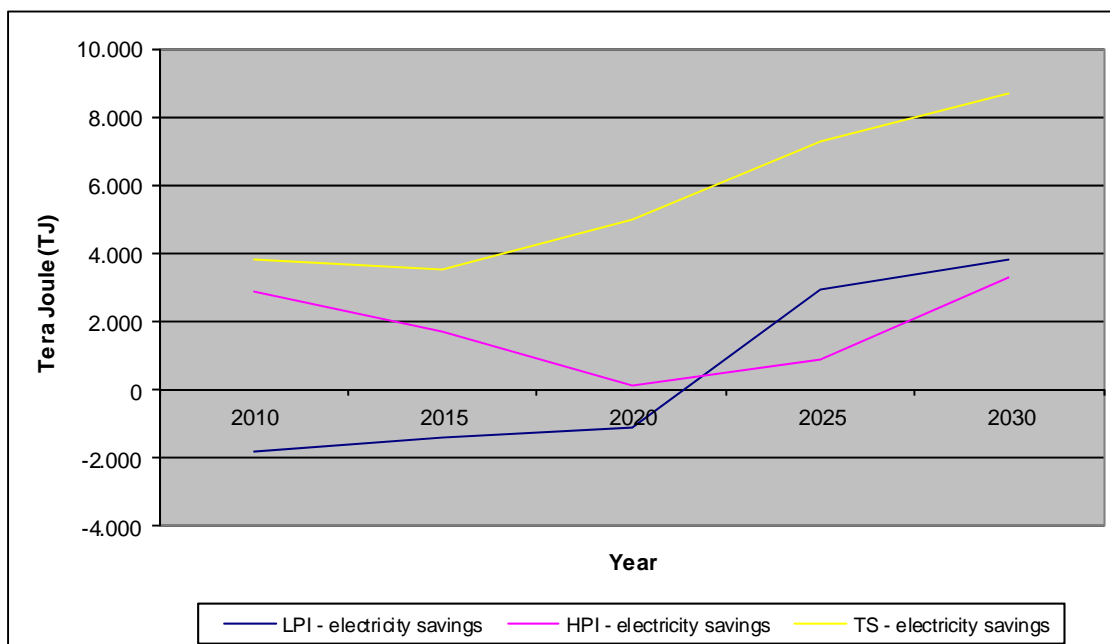

Source: own illustration, data based on www.eepotential.eu

18.3 TERTIARY SECTOR

The picture which evolves in the tertiary sector is similar to that of households. By ambitious economic policy intensities much more fuel can be saved compared to less ambitious policy intensities. However, compared to private households the potential fuel savings in the tertiary sector are relatively minor.

Figure 43 Fuel saving potential in the tertiary sector (Austria)

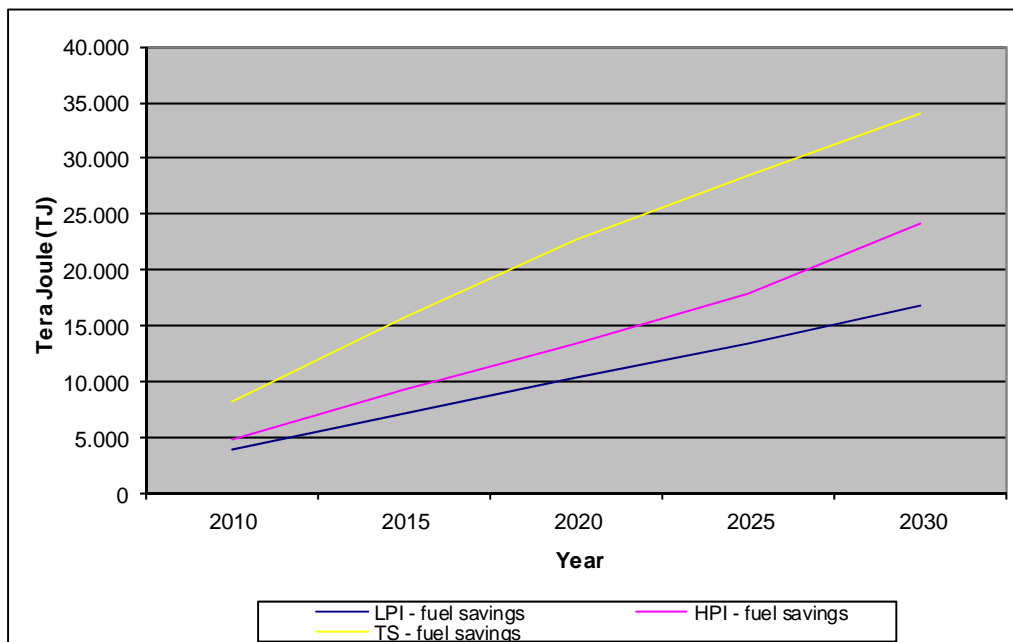

Source: own illustration, data based on www.eepotential.eu

Compared to the potential for fuel savings the potential for electricity savings in the tertiary sector is relatively moderate, although not negligible in absolute terms. It can be concluded from these data that highly ambitious policy intensities would not achieve a higher level of electricity savings than lower ambitious policy intensities. Within this area of energy saving actions, most potential is seen in office lighting, ventilation as well as commercial refrigeration and freezing.

Figure 44 Electricity saving potential in the tertiary sector (Austria)

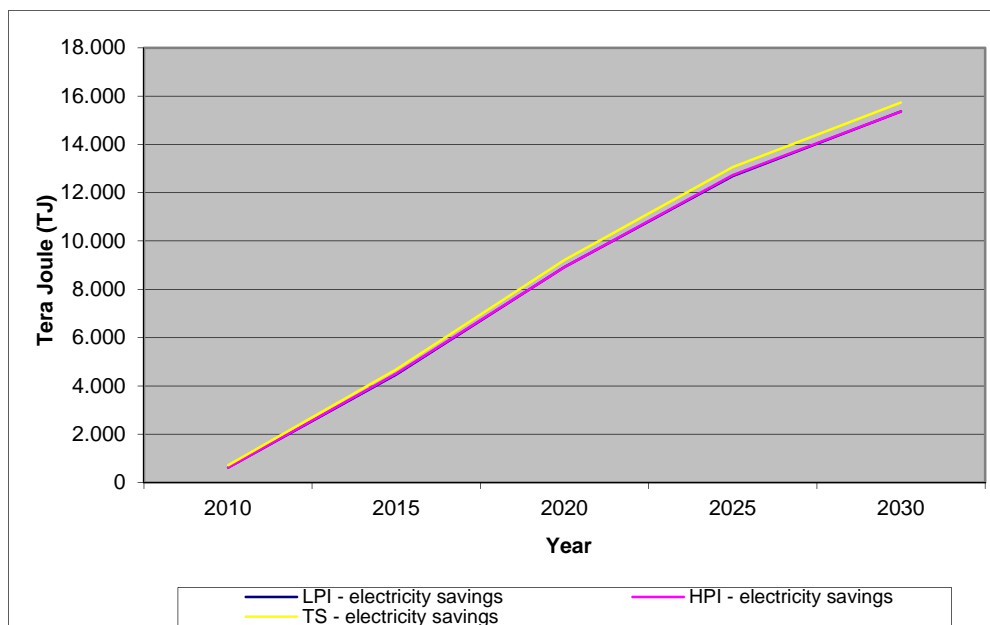

Source: own illustration, data based on www.eepotential.eu

18.4 TRANSPORT

The saving potential at transport of passengers is fairly high, already by applying low policy intensity to induce energy savings in this sector. By applying more ambitious policies saving potential can be raised considerably in absolute terms. According to data of the “eepotential”-database, applying technical measures comprise the bulk of saving potential in the area of passenger transport.

Figure 45 Total saving potential for passenger transport in Austria

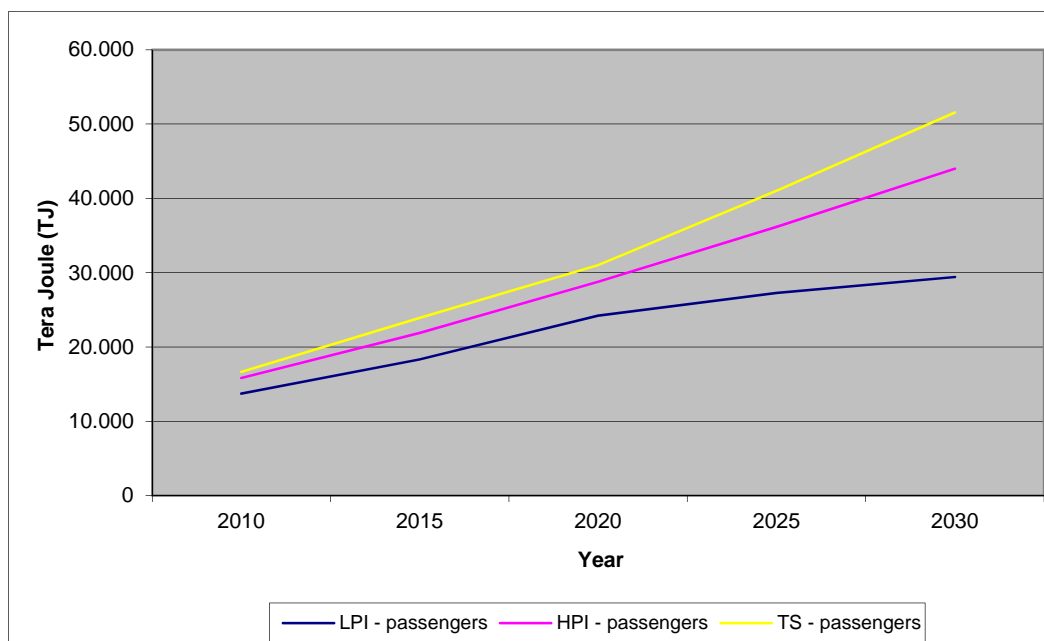

Source: own illustration, data based on www.eepotential.eu

Compared to the saving potential of passenger transport, the energy saving potential for goods transport shows a considerably different picture. Compared to passenger transport the energy saving potential in the goods transport sector is fairly small, although significant in absolute terms. However, energy saving potential could be raised considerably applying more ambitious policies. Once again, technical measures would lead to higher energy savings than non-technical measures⁴⁴⁸. However, the differential between possible savings due to technical measures and non-technical measures is not that significant as it is in the passengers transport sector.

⁴⁴⁸ According to data of www.eepotential.eu ; February 08, 2010

Figure 46 Total saving potential for goods transport in Austria

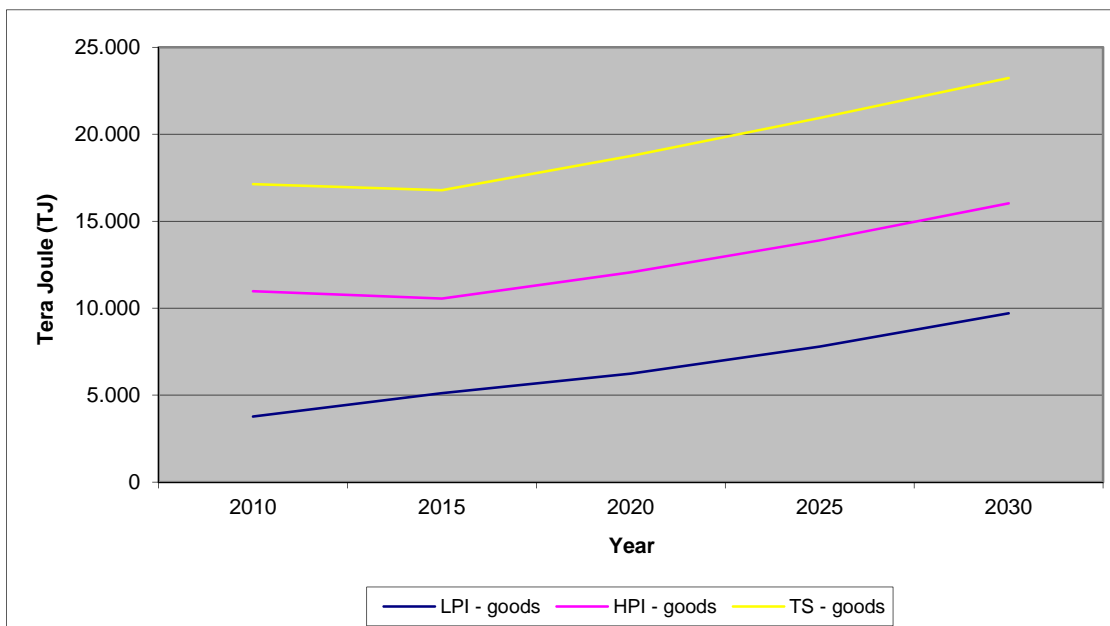

Source: own illustration, data based on www.eepotential.eu

18.5 INDUSTRY

Saving potentials in the sector industry are meaningful to an only limited extent for saving potentials in the non-EU-ETS area. For the sake of completeness the saving potential in this sector is displayed. The figures below show that the savings in fuels and electricity are similar.

Figure 47 Fuel saving potential in sector industry (Austria)

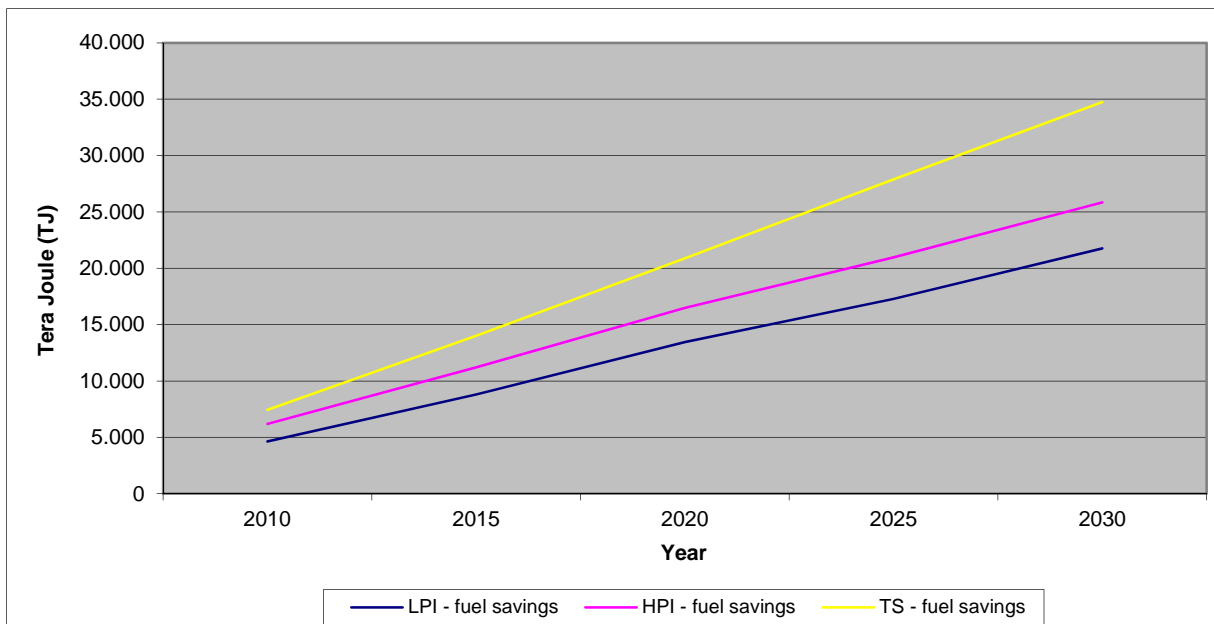

Source: own illustration, data based on www.eepotential.eu

The figures for fuel and electricity savings in the industry sector (Figure 47 and Figure 48) show that a more ambitious high policy intensity scenario might not lead to huge energy savings compared to less ambitious policies. A reason for that might be the pronounced cost awareness for energy use in this sector. However, in the long run – especially at fuel savings – substantial energy savings could be achieved by implementing more ambitious policies.

Figure 48 Electricity saving potential in sector industry (Austria)

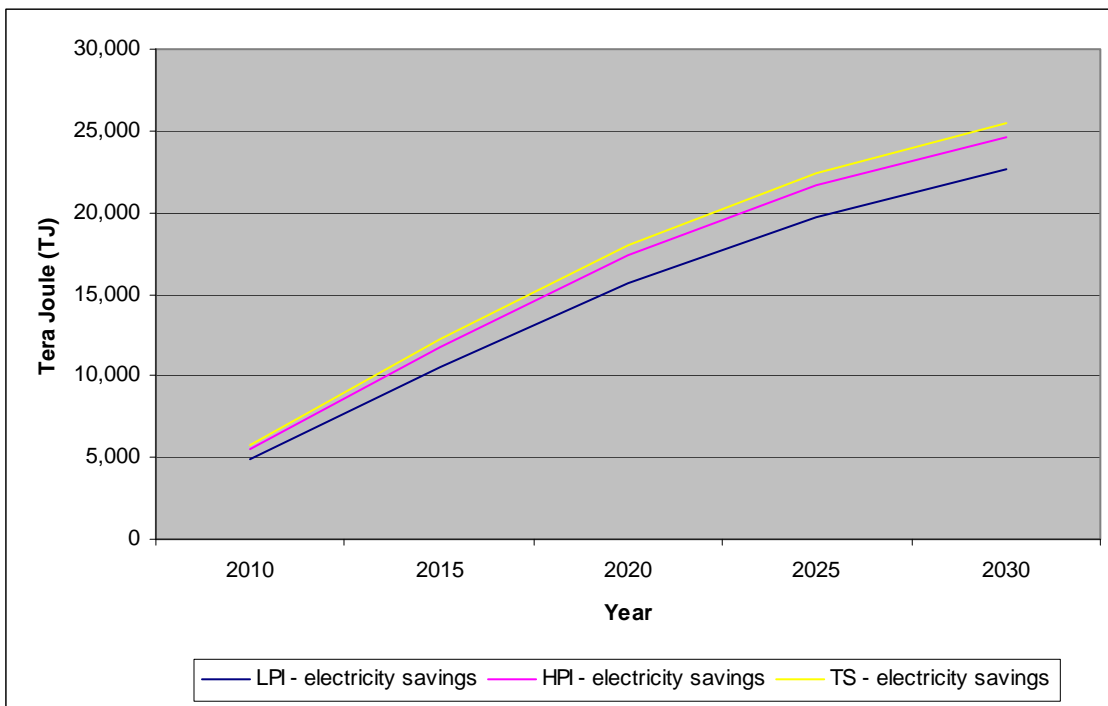

Source: own illustration, data based on www.eepotential.eu

Looking on the different technologies, especially heat generation as well as motors & lighting include energy saving potential. This is exemplarily shown for the low policy intensity (LPI) scenario in the next figure. However, data show that this statement is also true for more ambitious policy scenarios.

Figure 49 Industry saving potential by technology in Austria at a low policy intensity (LPI) scenario

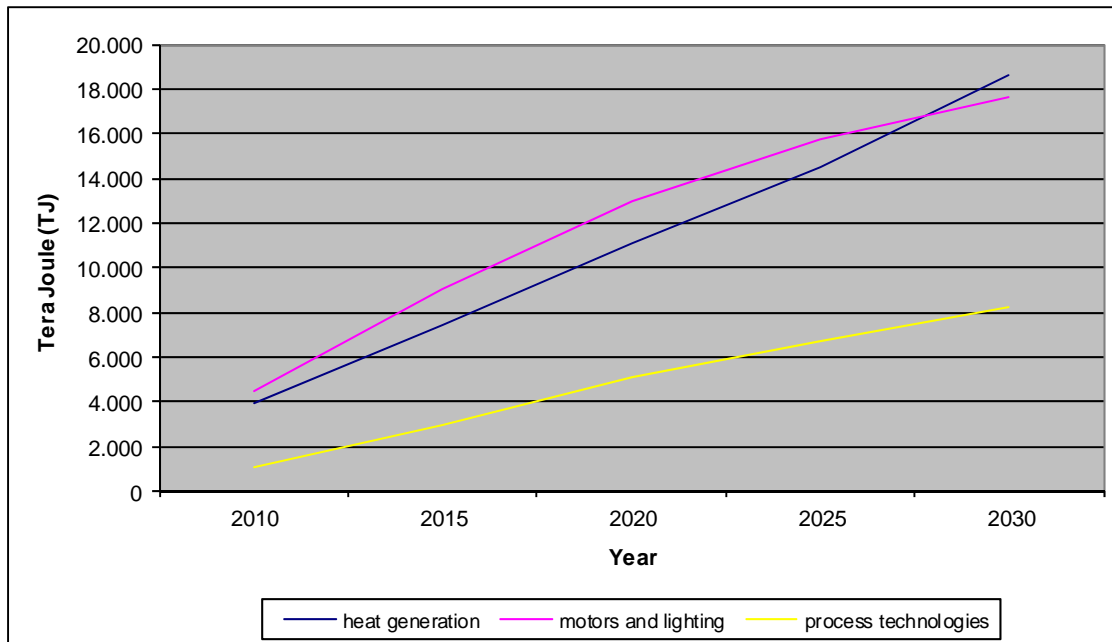

Source: own illustration, data based on www.eepotential.eu

Looking on the energy saving potential by industry branch it is shown that the paper and printing industry has most potential to save energy. Least energy saving potential is seen in the ferrous metals industry.

Figure 50 Industry saving potential by branch in Austria at a low policy intensity (LPI) scenario

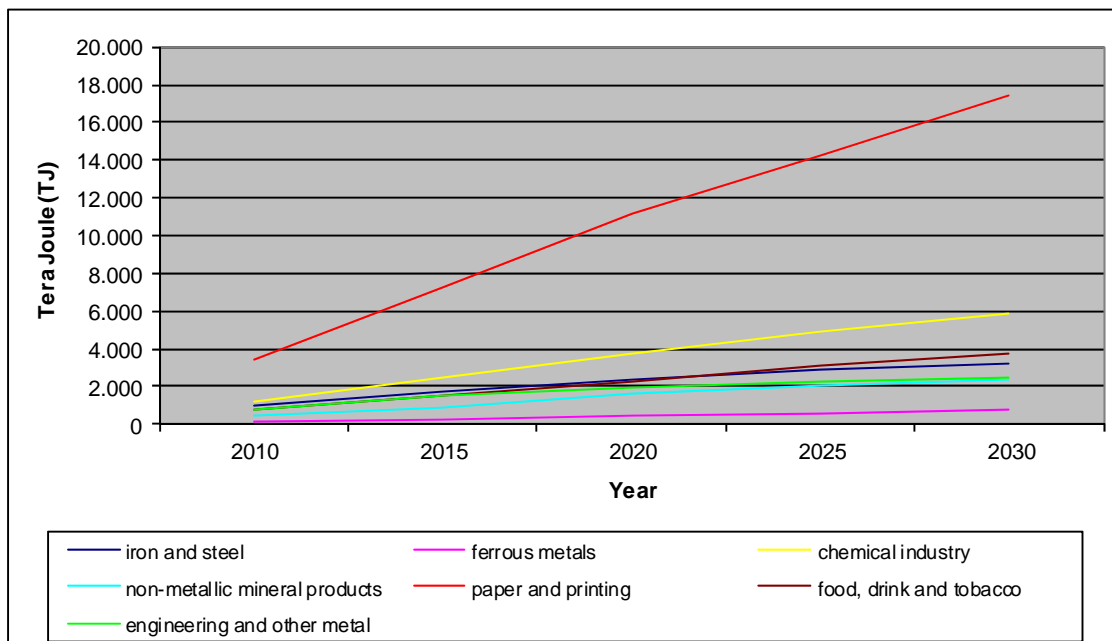

Source: own illustration, data based on www.eepotential.eu

19 Abbreviations

AAUs	Assigned Amount Units
BMLFUW	Austrian Federal Ministry for Agriculture, Forestry, Environment and Watermanagement
Capped Sectors	Sectors which are covered by a national or international emissions trading scheme
CH ₄	Methane (greenhouse gas)
CO ₂	Carbon dioxide (greenhouse gas)
CCX	Chicago Climate Initiative
CDM	Clean Development Mechanism
CERs	Certified Emission Reductions
CO ₂ e	Carbon dioxide equivalents
CNG	Compressed natural gas
DOP	Domestic Offset Programme
EUA	European Union Allowances
ECCP	European Climate Change Programme
ERU	Emission Reduction Units
ETS	Emission Trading Scheme
F-gases	Fluorinate gases (greenhouse gases)
GDP	Gross Domestic Product
IPCC	Intergovernmental Panel on Climate Change
JI	Joint Implementation
Mio. t.	Million (metric) tons
N ₂ O	Nitrous oxide (greenhouse gas)
PDD	Project Design Document
PRE	Project to Reduce Emissions (former New Zealand DOP scheme)
RGGI	Regional Greenhouse Gas Initiative
UNFCCC	United Nations Framework Convention on Climate Change

20 Bibliography

- Ahman, M., Cozjinsen, J., James, A., Reinaud, J., Phylipsen, D.** (2006): LETS Update – Working Group C Report; 04/2006.
- Amann, M., Cofala, J., Heyes, C., Klimont, Z., Mechler, R., Posch, M., Schöpp, W.** (2004): RAINS Review 2004. Documentation of the model approach prepared for the RAINS peer review 2004; IIASA; 02/2004; Laxenburg.
- Anderl, M., Gangl, M., Gugele, B., Ibesich, N., Köther, T., Muik, B., Poupa, S., Pazdernik, K., Schodl, B., Deweis, M., Kutschera, U.** (2009): Bundesländer Luftschadstoffinventur 1990-2007 (Datenstand 2009); Umweltbundesamt; REP-0238; Vienna.
- Armington, P.S.** (1969): A Theory of Demand for Products Distinguished by Place of Production; International Monetary Fund Staff Papers 16 (1969); pp.159-176.
- Aunan, K., Aaheim, A.H., Seip, H.M.** (2000): Ancillary Benefits of Greenhouse Gas Mitigation – an Overview; in OECD et al.; Reduced Damage to Health and Environment from Energy Saving in Hungary; Proceedings of an IPCC co-sponsored workshop; Washington D.C.; U.S.
- Barthel, C., Bunse, M., Irrek, W., Thomas, S., et al.** (2006): Optionen und Potentiale für Endenergieeffizienz und Energiedienstleistungen; Kurzfassung; Endbericht im Auftrag der E.ON AG; by Wuppertal Institute; Wuppertal; 05/2006.
- Bayerl, N.** (2008): Spezialisierungsmuster und Wertschöpfungsintensität der österreichischen Exportwirtschaft; in Materialien zu Wirtschaft und Gesellschaft Nr. 105; published by the Austrian Chamber of Labor; ISBN 978-3-7063-0353-8; 01/2008; Vienna.
- Betz, R., Rogge, K., Schoen, M.** (2006): Domestic Offset Projects: Limited opportunities in Germany but potential for others?; reprinted from “Energy & Environment; Volume 17, No 4, 569-583.
- Bickel, P., Friedrich, R.** (editors) et al. (2005): ExternE – Externalities of Energy; Methodology 2005 update; on behalf of the European Commission DG for Research Sustainable Energy Systems; EUR 21951.
- BMLFUW** (2007): Anpassung der Klimastrategie Österreichs zur Erreichung des Kyoto-Ziels 2008-2012; Department V / 4; 03/2007, Vienna.
- Bodiguel, A, Andre, Y, Leguet, B.** (2008): Domestic Offset Projects – Implementing the Kyoto-protocol; Agence de l’Environnement et de la Maitrise de l’Energie (ADEME) & Caisse des Depots; 05/2008, Paris.
- Bundesministerium für Land- und Forstwirtschaft, Umwelt und Wasserwirtschaft** (2007): Anpassung der Klimastrategie Österreichs zur Erreichung des Kyoto-Ziels 2008-2013; Vorlage zur Annahme im Ministerrat am 21. März 2007; Vienna.

- Bundesversammlung der Schweizerischen Eidgenossenschaft** (2007): Bundesgesetz über die Reduktion der CO₂-Emissionen; act of October 8, 1999, as amended on May 1, 2007; Bern/ Switzerland.
- Chicago Climate Initiative** (2007): Project based credits – offsets – in Chicago Climate Exchange; Overview and frequently asked questions.
- De Dominicis, A.** (2005): Domestic offset projects around the world; Mission Climat of Caisse des Dépôts; Research report no.5; 09/2005; Paris.
- Dirkse, S.P., Ferris, M.C.** (1993): The PATH solver – a non monotone stabilization scheme for mixed complementary problems; Working paper; University of Wisconsin; 09/1993; <https://eprints.kfupm.edu.sa/70795/1/70795.pdf> ; 01/2010.
- ECCP** (2007): Final Report of the 1st meeting of the ECCP working group on emissions trading on the review of the EU-ETS on the scope of the linking directive; 03/2007, Brussels.
- Eichhammer, W., Fleiter, T. Schlomann, B., Faberi, S., Fioretto, M., Piccioni, N., Leuchtenböhmer, S., Schüring, A., Resch, G.** (2009): Study on the Energy Saving Potentials in EU-Member States, Candidate Countries and EEA Countries; Final Report; ISIS/ Fraunhofer ISI/ Enerdata/ Wuppertal Institute/ Energy Economics Group of Technical University Vienna; for the European Commission Directorate-General Energy and Transport; Karlsruhe/ Grenoble/ Rome/ Vienna/ Wuppertal; 03/2009.
- Eidgenössisches Departement für Umwelt, Verkehr, Energie und Kommunikation UVEK** (2007): Richtlinie über freiwillige Maßnahmen zur Reduktion von Energieverbrauch und CO₂-Emissionen; act of July 2, 2001, as amended on July 2, 2007; Bern/ Switzerland.
- European Commission** (2006): Action plan for energy efficiency – tap the full potential; commission statement; 19th October 2006; Brussels.
- European Environment Agency:** EN35 External costs of electricity production.
- European Parliament** (2008): European Parliament legislative resolution of 17 December 2008 on the proposal for a directive of the European Parliament and of the Council amending Directive 2003/87/EC so as to improve and extend the greenhouse gas emission allowance trading system of the Community (COM(2008)0016 – C6-0043/2008 – 2008/0013(COD)).
- European Union** (2003): Directive 2003/87/EC of the European Parliament and of the Council of 13 October 2003 establishing a scheme for greenhouse gas emission allowance trading within the Community and amending Council Directive 96/61/EC; published in: “Official Journal of the European Union”.
- Fleischmann, E., Rainer, N.** (1985): Input-Output-Tabellen auf Basis von Make- und Adsorptionsmatrizen; Wirtschaftspolitische Blätter; No 4/1985; Vienna.
- Fübi, M., Seidel, W.** (2006): RWE Climate Bonus Project Heat Pumps; Joint Implementation Project Design Document; Version 01; Germany; 06/2006.
- Gemis-Österreich** (2008): Database of GEMIS (Globales Emissions-Modell Integrierter Systeme), Version 4.5; published by the Austrian Environment Agency; Vienna.

- Haas, R., Kranzl, L.** (2002): Bioenergie und Gesamtwirtschaft – Analyse der volkswirtschaftlichen Bedeutung der energetischen Nutzung von Biomasse für Heizzwecke und Entwicklung von effizienten Förderstrategien für Österreich; on behalf of the Austrian Federal Ministry for Transport, Innovation and Technology; Vienna; Austria; 09/2002.
- Handley, C., Bates, J., Phylipsen, D., Gilbert, A.** (2006): LETS Update – Scoping Phase Report; by AEA Technology Environment and Ecofys UK; 04/2006.
- Hantsch, S., Adensam, H., Salletmaier, E., Hessel, B., Holzinger, U.** (2002): Wirtschaftsfaktor Windenergie in Österreich: Arbeitsplätze – Wertschöpfung; on behalf of the Austrian Federal Ministry for Transport, Innovation and Technology; St. Pölten; Austria; 12/2002.
- Hicks, J.R.**, (1946): Value and Capital; Second edition; Oxford.
- Hofbauer, H., Schönberger, C., Bacovsky, D., Eder, G., Haslinger, W., Pointner, C., Wörgetter, M., Rauch, R., Jungmeier, G., Canella, L., Pucker, J., Hausberger, S.** (2008): FT-Treibstoffe aus Biomasse in Österreich – Biomassepotential, Technologien und ökonomische und ökologische Relevanz; final report; project identification number 812776; by Technical University of Vienna, Austrian Bioenergy Centre, Joanneum Research, Technical University of Graz; 12/2008.
- Hohmeyer, O.**, (2002): Vergleich externer Kosten der Stromerzeugung in Bezug auf das Erneuerbare Energien Gesetz; German Federal Environmental Agency; Berlin; 03/2002.
- Holland, M., Pye, S., Watkiss, P., Droste-Franke, B., Bickel, P.** (2005): Damages per tonne emission of PM2.5, NH3, SO2, NOx and VOCs from each EU25 Member State (excluding Cyprus) and surrounding seas; on behalf of the European Commission DG Environment; 03/2005.
- Holland, S., Watkiss, P.**: Benefits Table database – estimates of the marginal external costs of air pollution in Europe; Version E1.02a; by netcen; <http://ec.europa.eu/environment/enveco/air/pdf/betaec02aforprinting.pdf>.
- Holub, H-W., Schnabl, H.** (1994): Input-Output-Rechnung: Input-Output-Analyse – Einführung; University of Innsbruck & University of Stuttgart; Oldenburg Verlag Munich, Germany; ISBN 3-486-26581-4.
- IPCC** (2007): IPCC Fourth Assessment Report, The Physical Science Basis, Technical Summary.
- Jamieson, R.E., Brasell, M.R., Wakelin, W.** (2005): Projects to reduce greenhouse gas emissions in New Zealand; <http://www.ipenz.org.nz/ipenz/forms/pdfs/TreNz6.pdf>; December 10, 2008.
- Jornini, P., McDougall, R., Watts, G., Dee, P.S.** (1994): The SALTER model of the world economy – model structure, database and parameters; Industry Commission; Canberra; http://www.pc.gov.au/_data/assets/pdf_file/0020/73127/workingpaper24.pdf; last visited May 14, 2010
- Karner, A., Kletzan, D., Kraner, H., Harather, K.** [1] (2005): Evaluierung der Umweltförderung des Bundes für den Zeitraum 01.01.2002 bis 31.12.2004; published by the Austrian Ministry for the Environment; Vienna.

- Karner, A., Kletzan, D., Kraner, H., Harather, K.** [2] (2008): Evaluierung der Umweltförderung des Bundes für den Zeitraum 01.01.2005 bis 31.12.2007; published by the Austrian Ministry for the Environment; Vienna.
- Kletzan-Slamanig, D., Köppl, A., Artner, H., Karner, A., Pfeffer, T.** (2008): Energieeffiziente Gebäude – Potentiale und Effekte von emissionsreduzierenden Maßnahmen; WIFO and KWI; Vienna; October 2008.
- Kletzan, D., Steininger, K., Hochwald, J.** (2005): Gesamtwirtschaftliche Effekte der klimarelevanten Massnahmen im Rahmen der Umweltförderung im Inland 2004; WIFO and Wegener Center of the University Graz; 11/2005.
- Kollmuss, A., Zink, H., Polycarp, C.** (2008): Making sense of the voluntary carbon market – a comparison of carbon offset standards; Stockholm Environment Institute, Tricorona; published by WWF Germany; 03/2008; http://assets.panda.org/downloads/vcm_report_final.pdf.
- Kommission der Europäischen Gemeinschaften** (2008a): Vorschlag für eine Entscheidung des Europäischen Parlaments und des Rates über die Anstrengungen der Mitgliedstaaten zur Reduktion ihrer Treibhausgasemissionen mit Blick auf die Erfüllung der Verpflichtungen der Gemeinschaft zur Reduktion der Treibhausgasemissionen bis 2020; KOM(2008) 17 endgültig; Brussels.
- Kommission der Europäischen Gemeinschaften** (2008b): Vorschlag für eine Richtlinie des Europäischen Parlaments und des Rates zur Förderung der Nutzung von Energie aus erneuerbaren Quellen; KOM(2008) 19 endgültig; Brussels.
- Kommission der Europäischen Gemeinschaften** (2008c): Mitteilung der Kommission an das Europäische Parlament, den Rat, den Europäischen Wirtschafts- und Sozialausschuss der Regionen: 20 und 20 bis 2020. Chancen Europas im Klimawandel; KOM(2008) 30 endgültig; Brussels.
- Kommunalkredit Public Consulting** [1] (2008): Österreichs JI/CDM Programm 2008; published by Austrian Ministry for the Environment; Vienna.
- Kommunalkredit Public Consulting** [2] (2008): Climate Austria – Bericht 2008; Vienna.
- Kommunalkredit Public Consulting** [3] (2009): Umweltförderungen des Bundes 2008; published by Austrian Ministry for the Environment; Vienna.
- Kommunalkredit Public Consulting** [4] (2010): Climate Austria – Bericht 2009; Vienna.
- Kratena, K., Puwein** (2002): Volkswirtschaftliche Auswirkungen einer fahrleistungsabhängigen LKW-Maut; Austrian Institute of Economic Research (WIFO); published in WIFO monthly report 2/2002; pp.107-119; Vienna.
- Krewitt, W., Schломann, W.**, (2006): Externe Kosten der Stromerzeugung aus erneuerbaren Energien im Vergleich zur Stromerzeugung aus fossilen Energieträgern; Institute of Technical Thermodynamics, Fraunhofer Institute for Systems and Innovation Research; 4/2006; Germany; http://www.dlr.de/tt/Portaldat/41/Resources/dokumente/institut/system/publications/ee_kosten_stromerzeugung.pdf.

- Krupnick, A., Burtraw, D., Markandya, A.** (2000): “The Ancillary Benefits and Costs of Climate Change Mitigation: A Conceptual Framework”; in OECD et al; 53-93; Ancillary Benefits of Greenhouse Gas Mitigation, Proceedings of an IPCC Co-Sponsored Workshop; Washington D.C.; 2000.
- Lebensministerium** (2008): Erneuerbare Energie 2020. Potentiale in Österreich. Schlussfolgerungen der Task Force "Erneuerbare Energie"; Vienna; 05/2008.
- Lechner, H., Mayer, J., Pierrard, R.** (1998): Vergleich von Energieträgern und Heizsystemen zur Raumwärmeversorgung; by Austrian Energy Agency; on behalf of the Austrian „Institut fuer wirtschaftliche Oelheizungen“; Vienna.
- Leguet, B., Arnaud, E., De Dominics, A., Leseur, A., De Perthuis, C.** (2005): Expanding the means to combat climate change through domestic offset projects; Caisse des Dépôts; Executive Summary; 11/2005; Paris.
- Lloyd, P.J., Zhang, X.** (2009): The Armington Model; University of Melbourne and Productivity Commission; Australia; http://www.ecom.unimelb.edu.au/downloads/nus_symposium/Lloyd_paper.pdf; 01/2009.
- Lorenz-Meyer, V., Gugele, B., Pazdernik, K., Wappel, D.** (2007): Kyoto Fortschrittsbericht – Österreich 1990-2005; published by Austrian Federal Environmental Agency; Vienna.
- Maibach, M., Schreyer, C., Sutter, D., van Essen, H.P., Boon, B.H., Smokers, R., Schrotten, A., Doll, C., Pawlowska, B., Bak, M.** (2007): Handbook on estimation of external costs in the transport sector; produced within the study “Internalisation Measures and Policies for All external Costs of Transport” (IMPACT); Version 1.0; INFRAS, CE Delft, Fraunhofer Gesellschaft – ISI; University of Gdansk; Publication number 07.4288.52; commissioned by the European Commission DG TREN; 12/2007.
- McCarl, B. A., Meeraus, A., van der Eijk, P., Bussieck, M., Dirkse, S., Steacy, P.** (2008): McCarl GAMS user guide; Texas A&M University and GAMS Development Corporation; Version 22.7; USA.
- McKinsey** (2007): Kosten und Potentiale der Vermeidung von Treibhausgasemissionen in Deutschland; on behalf of „Bundesverband der Deutschen Industrie e.V.“; 09/2007; Berlin.
- New Zealand Ministry for the Environment** (2007): The framework for a New Zealand emission trading scheme; Executive summary; ME 810; 09/2007; Wellington.
- New Zealand Ministry for the Environment** (2008): New Zealand’s guidelines and procedures for track 1 Joint Implementation under the Kyoto-protocol – applicable for projects in New Zealand under the Projects to Reduce Emissions programme and for the Te Apiti and Tararua wind farms; Wellington; 06/2008.
- Österreichische Bundesregierung** (2003): Energiebericht 2003; Vienna.
- Pazdernik, K., Anderl, M., Gangl, M., Göttlicher, S., Köther, T., Muik, B., Poupá, S., Schodl, B., Storch, A., Wappel, D., Wieser, M.** (2009): Emissionstrends 1990-2007; report by Austria Environmental Agency; REP-0234; ISBN 978-3-99004-033-1; Vienna.

- Perman, R., Ma, Y., McGilvray, J., Common, M.** (1999): Natural Resource & Environmental Economics; Second Edition; published by Pearson Education Limited; ISBN 978-0-273-65559-6.
- Perman, R., Ma, Y., McGilvray, J., Common, M.** (2003): Natural Resource & Environmental Economics; Third Edition; published by Pearson Education Limited; ISBN 0 582 36876 6.
- Pfaffenberger, W., Nguyen, K., Gabriel, J.** (2003): Ermittlung der Arbeitsplätze und Beschäftigungswirkungen im Bereich Erneuerbarer Energien; published by Bremer Energie Institut; commissioned by Hans-Boeckler-Foundation; 12/2003.
- Peterson, S.** (2006): Efficiency Abatement in Separated Carbon Markets: A Theoretical and Quantitative Analysis of the EU Emissions Trading Scheme; Kiel Institute for World Economics; Kieler Working Paper No. 1271; 03/2006; Germany.
- Pötscher, F.** (2009): CO₂-Monitoring 2009. Zusammenfassung der Daten der Republik Österreich gemäß Entscheidung Nr. 1753/2000/EG für das Berichtsjahr 2008; Austrian Federal Environmental Agency; on behalf of Austrian Ministry for the Environment; Vienna
- Prettenthaler, F., Dalla-Via, A., Gobiet, A., Fank, J., Kurzmann, R., Oberauer, I., Toeglhofer, C., Truhetz, H., Zakarias, G.** (2007): Wasser & Wirtschaft im Klimawandel – Konkrete Ergebnisse am Beispiel der sensiblen Region Oststeiermark; Joanneum Research & University of Graz; dissemination by the Austrian Academy of Sciences.
- Prettenthaler, F., Steiner, D., Schlamadinger, B.** (2006): Billige Credits oder heimische Arbeitsplätze?- Zur Evaluierung der Effizienz von Kyotomaßnahmen unter Berücksichtigung von umweltpolitischen und ökonomischen Co-Effekten; in Wirtschaftspolitischen Blättern – focal point environmental economics; Manz Verlag, publisher Austrian chamber of commerce; issue 4/2006.
- Raa, T.T.** (2005): The economics of input-output analysis; Cambridge University Press, UK.
- Rabl, A., Spadaro, J., Bickel, P., Friedrich, R., Droste-Franke, B., Preiss, P., Panis, L.I., Diskoulaki, D., Markandya, A., Hunt, A., Scasny, M., Melichar, J., Havranek, M., Maca, V., Foltynova, H., Dones, R., Heck, T., Bauer, C., Hirschberg, S., Kudelko, M.** (2005): Externalities of Energy – Extension of accounting framework and policy applications (ExternE-Pol); final technical report; 08/2005.
- Rabl, A., Spadaro, J.V., van der Zwaan, B.** (2005): Uncertainty of Pollution Damage Cost Estimates: to What Extent does it Matter?; Environmental Science and Technology; Vol. 39(2); pp. 399-408.
- Rechnungshof** (2008): Report of the Austrian Court of Audit regarding the implementation of the Austrian climate strategy by the federal government; Bund 2008/11; Vienna.
- Reinert, K.A., Roland-Holst, D.W.** (1992): Disaggregated Armington elasticities for the mining and manufacturing sectors of the United States; published in Journal of Policy Modeling; Vol. 14, No. 5, pp. 631-639, 1992; <http://mason.gmu.edu/~kreinert/paperspdf/armingjpm.pdf> .
- RGGI [1]** (2007): Regional Greenhouse Gas Initiative Model Rule, 05/2007.
- RGGI [2]** (2007): Overview of RGGI Co₂ Budget Trading Program, 10/2007; http://www.rggi.org/docs/program_summary_10_07.pdf .

- RGGI** [3] (2008): Regional Greenhouse Gas Initiative Model Rule; revised version; 12/2008.
- Roberts, S., Thumim, J.** (2006): A rough guide to individual carbon trading – the ideas, the issues and the next steps; Centre for Sustainable Energy; Report to Defra; UK; 11/2006.
- Rosenthal, R. E.,** (2008): GAMS – A user’s guide; GAMS development corporation; Washington D.C.; USA.
- Rothe, M., Seidel, W., Marx, G.** (2007): Pilot Programmatic Joint Implementation project in North Rhine-Westfalia (JIM.NRW); Joint Implementation Project Design Document; Version 02; Germany; 09/2007.
- Rutherford, T.F.** (1998): Economic Equilibrium Modeling with GAMS. An Introduction to GAMS/MCP and GAMS/MPSGE; University of Colorado; 06/1998; <http://www.gams.com/dd/docs/solvers/mpsge.pdf>; January 25, 2010.
- Rutherford, T.F.** (1999): Applied General Equilibrium Modeling with MPSGE as a GAMS Subsystem – An Overview of the Modeling Framework and Syntax; published in Computational Economics; Vol. 14, 1999; pp. 1-46.
- Salchenegger, S.** (2006): CO2-Monitoring 2005. Zusammenfassung der Daten der Republik Österreich gemäß Entscheidung Nr. 1753/2000/EG für das Berichtsjahr 2005; Umweltbundesamt; publisher Austrian Ministry for the Environment; Report REP 00-55; Vienna.
- Sattler, M., Lang, B., Lutter, E.** (2005): Erfassung und Evaluierung der kyotorelevanten Förderungen in Österreich; published by Austrian Energy Agency; on behalf of the Austrian Ministry of Agriculture, Forestry, Environment and Water Management; Vienna; 09/2005.
- Sattler, M., Adensam, H., Hofer, S., Tretter, H., Holzmann, A.** (2008): EE-Pot . Abschätzung der Energieeffizienz-Potentiale in Österreich bis zum Jahr 2020; final report; by Austrian Energy Agency; on behalf of the Austrian Federal Ministry of Economy and Labor; 04/2008; Vienna.
- Schleicher, S., Kratena, K.** (2001): Österreichs Klimapolitik: die Chance des Scheiterns; in „Wissenschaft & Umwelt INTERDISZIPLINÄR“; No. 4/2001; pp. 11-22.
- Schneider, L.** (2007): Is the CDM fulfilling its environmental and sustainable development objectives? An evaluation of the CDM and options for improvement; Institute for Applied Ecology; prepared for WWF; Berlin.
- Schneider, J., Wappel, D.** et al. (2008): Klimaschutzbericht 2008; Austrian Environment Agency; REP-0150; ISBN 3-85457-947-0; Vienna.
- Schneider, J., Wappel, D.** et al. (2009): Klimaschutzbericht 2009; Austrian Environment Agency; REP-0226; ISBN 978-3-99004-024-9; Vienna.
- Schneider, J., Kuschel, V.** et al. (2010): Klimaschutzbericht 2010; Austrian Environment Agency; REP-0267; ISBN 978-3-99004-024-9; Vienna.
- Schweizer Bundesamt für Umwelt (BAFU), Schweizer Bundesamt für Energie (BFE)** (2008): Klimaschutzprojekte in der Schweiz – Vollzugsweisung zur Durchführung von Kompensationsmaßnahmen; Joint communication of BAFU and BFE; Bern.

- Schwermer, S.** (2007): Ökonomische Bewertung von Umweltschäden – Methodenkonvention zur Schätzung externer Umweltkosten; report by the German Federal Environment Agency; Germany; 04/2007.
- Sen, H.** (1996): Social Accounting Matrix (SAM) and its implications for macroeconomic planning; Bradford University; Development Project Planning Center (DPPC); unpublished assessed article; Bradford, UK.
- Shiells, C.R., Reinert, K.A.** (1993): Armington Models and Terms-of-Trade Effects: Some Econometric Evidence for North America; The Canadian Journal of Economics; Vol. 26; No. 2 (May, 1993), pp. 299-316.
- Smuda, A.** (2009): A road to domestic offsetting in the EU; Guest commentary by German Emissions Trading Authority (DEHST) published in Carbon Market Europe, Vol. 8, Issue 21; May 29, 2009.
- Statistik Austria** (2006): Verbrauchsausgaben – Hauptergebnisse der Konsumerhebung 2004/05; ISBN 3-902479-64-7; Vienna.
- Statistik Austria** (2009): Integrierte Statistik der Lohn- und Einkommenssteuer 2006; ISBN 978-3-902703-05-7; Vienna.
- Statistik Austria** (2010): Input-Output-Tabelle inklusive Aufkommens- und Verwendungstabelle; ISBN 978-3-902703-37-8; Vienna.
- Steiner, D.** (2006): Evaluation of Efficiency of Greenhouse Gas Mitigation Measures under Consideration of Environmental, Social and Economic Co-Effects; Master's thesis in cooperation with JOANNEUM RESEARCH (Prettenthaler, F., Schlamadinger, B.).
- Steininger, K., Berdnik, S., Gebetsroither, B., Getzner, M., Hausberger, S., Hochwald, J.** (2007): Klimaschutz, Infrastruktur und Verkehr; Wegener Center of the University of Graz; Scientific Report No: 15-2007; 08/2007.
- Steininger, K., Kettner, C., Kufleitner, A., Loibnegger, T., Pack, A., Schleicher, S., Töglhofer, C., Trink, T.** (2008): Volkswirtschaftliche Effekte einer erweiterten Biomasse-Energie-Nutzung in der Energieregion Oststeiermark; Wegener Center for Climate and Global Change – University Graz; on behalf of the Austrian Federal State of Styria; scientific report no. 21-2008; 05/2008; Graz, Austria.
- Sterk, W., Arens, C.** (2006): Die projektbasierten Mechanismen CDM & JI – Einführung und praktische Beispiele; published by the German Ministry for the Environment; Berlin; 11/2006.
- Sterner, T., Höglund Isaksson, L.** (2006): Refunded emission payments theory, distribution of costs, and Swedish experience of NOx abatement; University of Göteborg, Resources for the Future, International Institute for Applied Systems Analysis; published in: Ecological Economics 57 (2006) 93-106.
- Umweltbundesamt** (2007): Emissionshandel: CO₂-Emissionen 2006 – Auswertung der Ist-Emissionen des Emissionshandelssektors im Jahr 2006 in Deutschland; 05/2007; Germany.
- UNDP** (2010): Human Development Report 2010 – The real wealth of nations: Pathways to human development; 20th Anniversary Edition; ISBN 978-0-230-28445-6; <http://hdr.undp.org> .

United Nations (1968): A System of National Accounts; Department of economic and social affairs – Statistical office of the United Nations; Studies in methods; Series F; No. 2; Rev.3; New York.

United Nations (1998): Kyoto Protocol to the United Nations Framework Convention on Climate Change.

UNFCCC/CCNUCC (2004): Tool for the demonstration and assessment of additionality; by CDM-Execute Board; Version 03; EB 29; October 22, 2004.

UNFCCC (2009): National greenhouse gas inventory data for the period 1990-2007; subsidiary body for implementation; FCCC/SBI/2009/12; October 21, 2009; <http://unfccc.int/resource/docs/2009/sbi/eng/12.pdf>.

Wartmann, S., Harnisch, J., Phylipsen, D., Gilbert, A. (2006): Inclusion of additional activities and gases into the EU-Emissions Trading Scheme; Report under the project “Review of EU Emissions Trading Scheme; written by Ecofys; assigned by European Commission – Directorate General for Environment; 10/2006.

WCI Offset Subcommittee (2008): Summary of major options for a GHG offset system to support the WCI program; <http://www.westernclimateinitiative.org/ewebeditpro/items/O104F14585.PDF>; January 17, 2008.

WCI Scope Subcommittee (2008): Draft Program Scope Recommendations; <http://www.westernclimateinitiative.org/ewebeditpro/items/O104F16031.PDF> ; April 22, 2008.